

F - ATTENTION!  
 GB - WARNING!  
 D - ACHTUNG!  
 NL - WAARSCHUWING!  
 E - ¡ADVERTENCIA!  
 P - ATENÇÃO!  
 I - AVVERTENZA!  
 DK - ADVARSEL!  
 S - VARNING!  
 FIN - VAROITUS!  
 N - ADVARSEL!  
 H - FIGYELMEZTETÉS!  
 CZ - UPOZORNĚNÍ!  
 SK - UPOZORNENIE!

PL - OSTRZEŻENIE!  
 BG - ВНИМАНИЕ!  
 RO - AVERTISMENT!  
 GR - ΠΡΟΕΙΔΟΠΟΙΗΣΗ!  
 SI - OPOZORILO!  
 HRV - UPOZORENJE!  
 TR - UYARI!  
 RU - ВНИМАНИЕ!  
 UA - УВАГА!  
 ET - HOIATUS!  
 LT - DĖMESIO!  
 LV - UZMANĪBU!  
 AR - تنبيه!

**+2**  
 ans  
 years  
 Jahre  
 jaar  
 años  
 anos  
 anni  
 år  
 år  
 vuotta  
 är  
 év  
 let  
 rokov  
 lata  
 години  
 ani  
 χρόνια  
 سنوات



X2

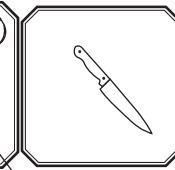
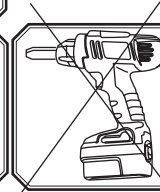

**Smoby**

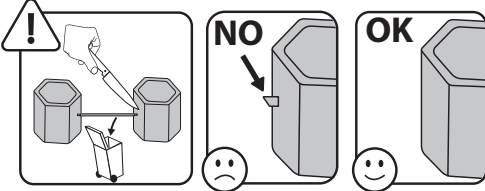









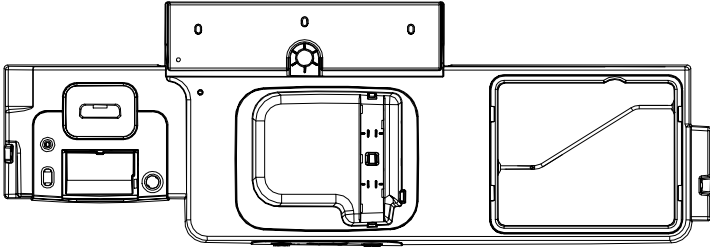

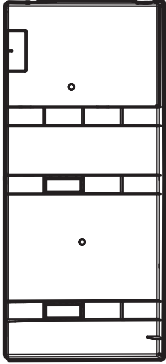
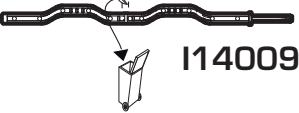
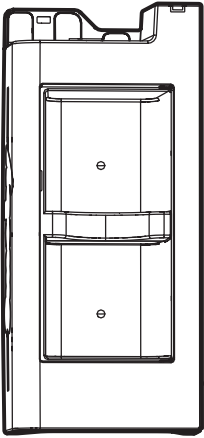

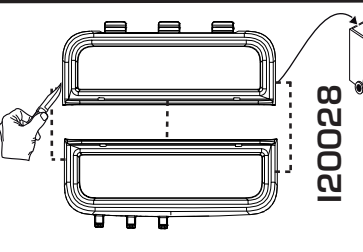

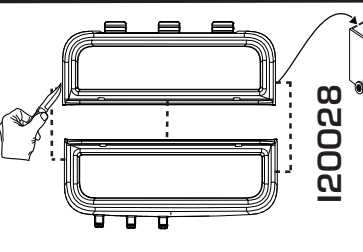
F - Outils non fournis  
 GB - Tools not provided.  
 D - Werkzeug nicht inbegriffen  
 NL - Gereedschap niet inbegrepen  
 E - Herramientas no incluidas.  
 P - Ferramentas não incluídas.  
 I - Utensili non forniti  
 DK - Værktøj medfølger ikke.  
 S - Verktyg ingår inte.  
 FIN - Ei sisällä työkaluja

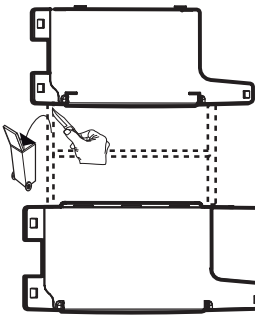
N - Verktøy følger ikke med  
 H - A szerszámok nem tartozékaik a terméknek.  
 CZ - Nářadí není součástí dodávky  
 SK - Nariadenie nie je súčasťou dodávky  
 PL - Narzędzia niedostarczone w zestawie.  
 BG - Инструменти не са предоставени.  
 RO - Sculele nu includ  
 GR - Τα εργαλεία δεν περιλαμβάνονται  
 SI - Orodje ni priloženo.  
 HRV - Alati se ne isporučuju

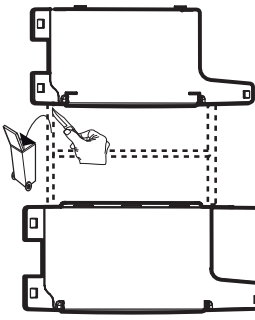
TR - Ürüne dahil değildir  
 RU - Инструменты не поставляются.  
 UA - Інструменти не входять у комплект  
 EE - Tööriistu ei ole kaasas  
 LT - Įrankių komplektė nėra  
 LV - Rīki komplektā nav ietverti.  
 •AR الأدوات غير مرفقة مع المنتج.

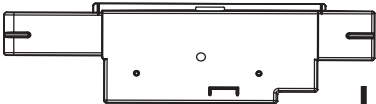
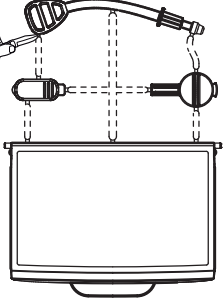
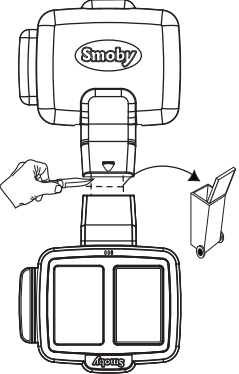
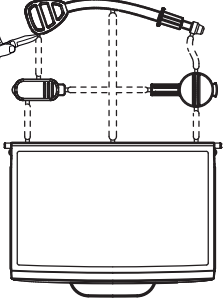
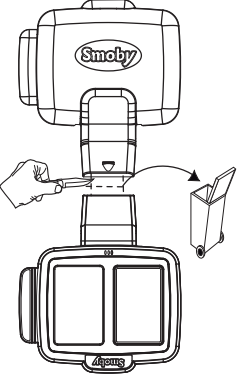
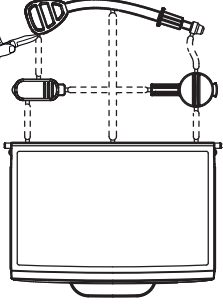
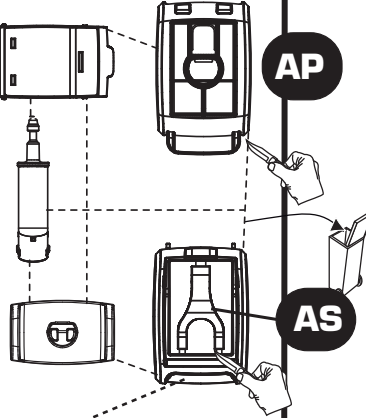
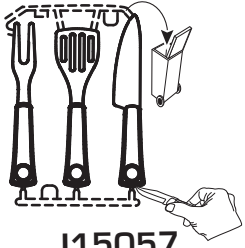
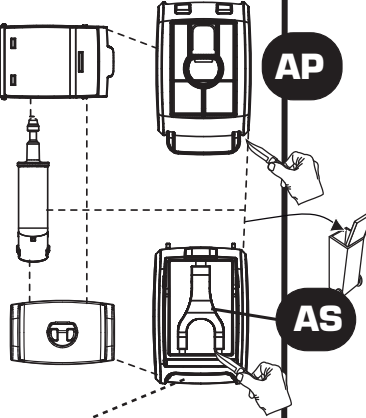
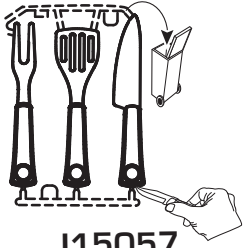
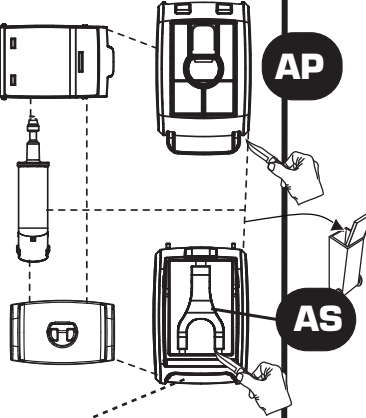
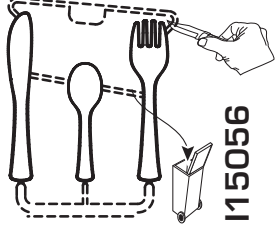
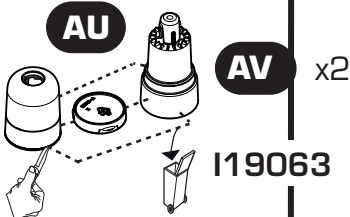
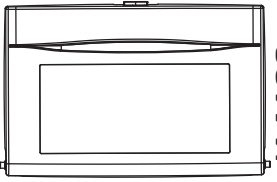
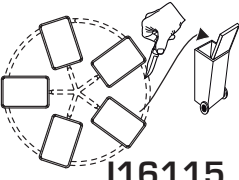
<b>A</b>			<b>F</b>		120032	x1
<b>A1</b>		I11005	<b>G</b>		120027	x1
<b>B1</b>			<b>H</b>		120026	x1
<b>B</b>		S11002	<b>J</b>		120029	x1
<b>C</b>		I11007	<b>K</b>			x1
<b>D</b>			<b>L</b>		120030	<b>M</b>
<b>E</b>		I11008	<b>N</b>		S13005	x1
			<b>P</b>		120038	x2
			<b>Q</b>		120031	x1
			<b>V</b>		348790	x4
			<b>W</b>		I13032	x2
			<b>Y</b>		I17019	x18
			<b>Z</b>		I17020	x12
			<b>AA</b>		∅6x20 AAK0414	X26
			<b>AB</b>		∅4,5x20 AAK0401	x30

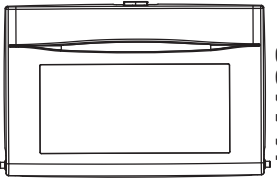
AD		x1	I20026	x1	AY		x1
AE		x1	I14120	x1	AZ		x1
AF		x1	I17049	x1	BA		x1
AG		x1	I20028	x1	BB		x1
AH		x1	I20028	x1	BC		x1
AI		x1	I14122	x1	BD		x2
AJ		x1	I14122	x1	BE		x2
AK		x1	I14131	x1	BF		x1
AL		x1	I21074	x1	BG		x1
AM		x1	I21074	x1	BH		x1
AN		x1	I21075	x1	BI		x1
AO		x1	I21075	x1	B1		x1
AR		x1	I21075	x1	B11		x2
AT		x2	I19063	x2	BJ		x2
AW		x1	I16115	x1	I14008		x1
AX		x1	I14008	x1	I14126		x2

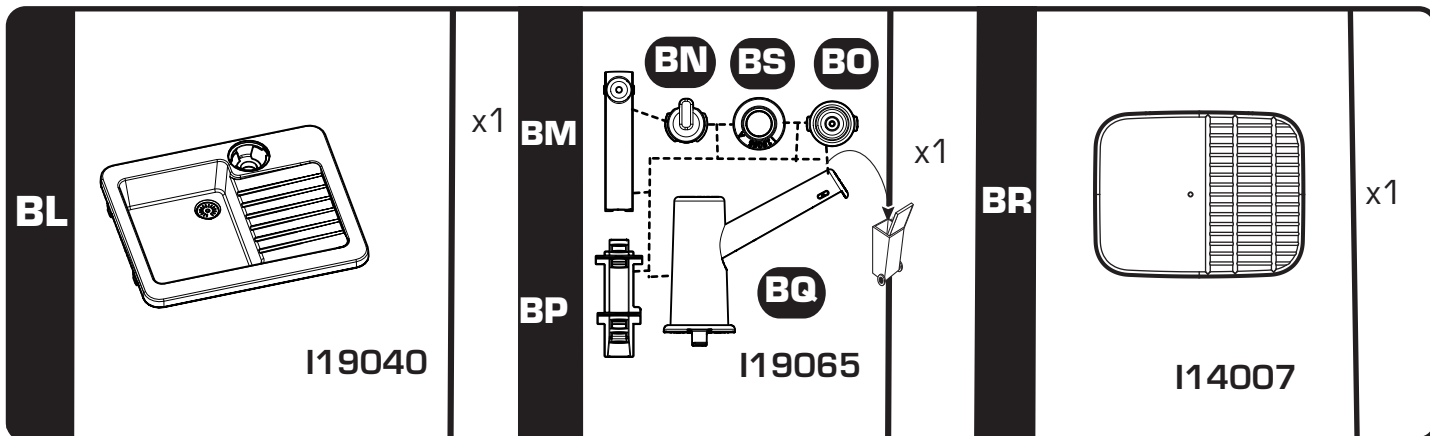

**Aide montage vidéo :**  
**Help : assembly instructions in video :**

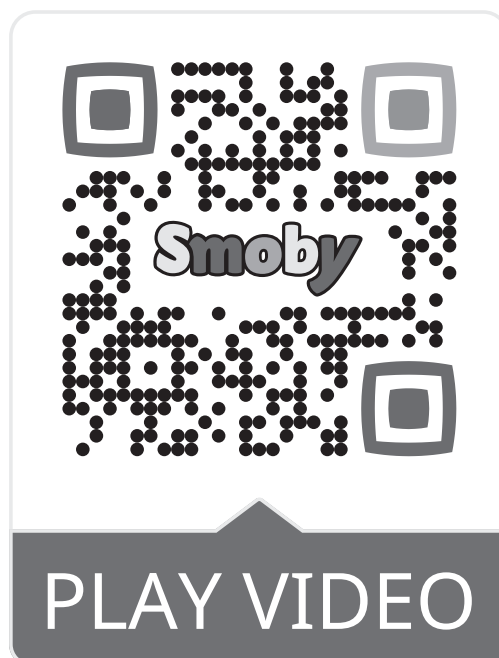

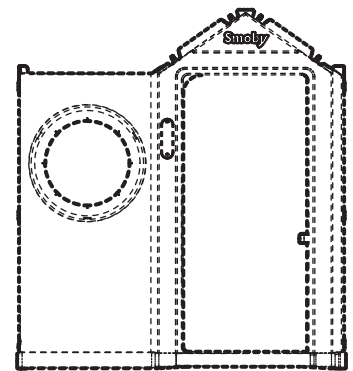
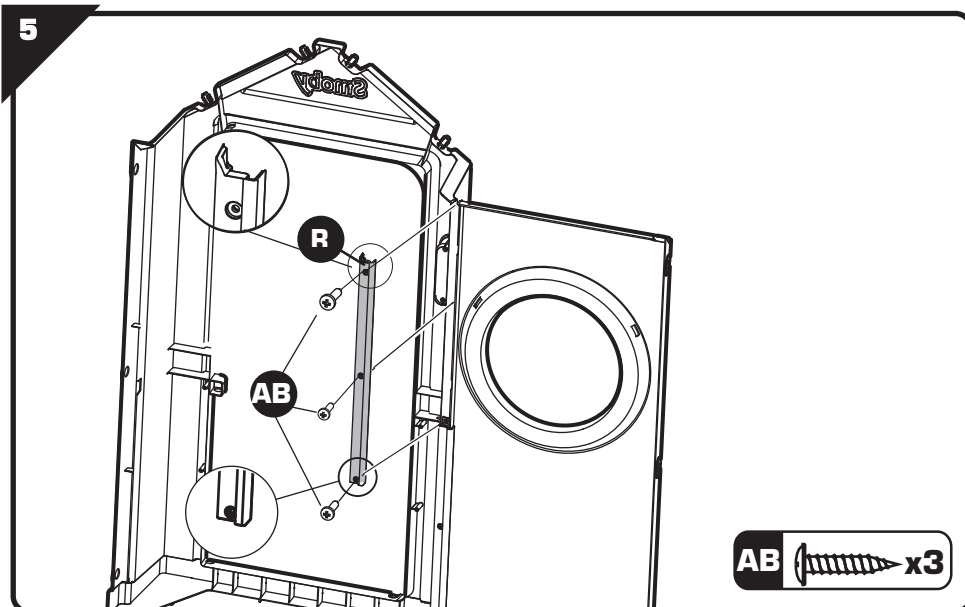
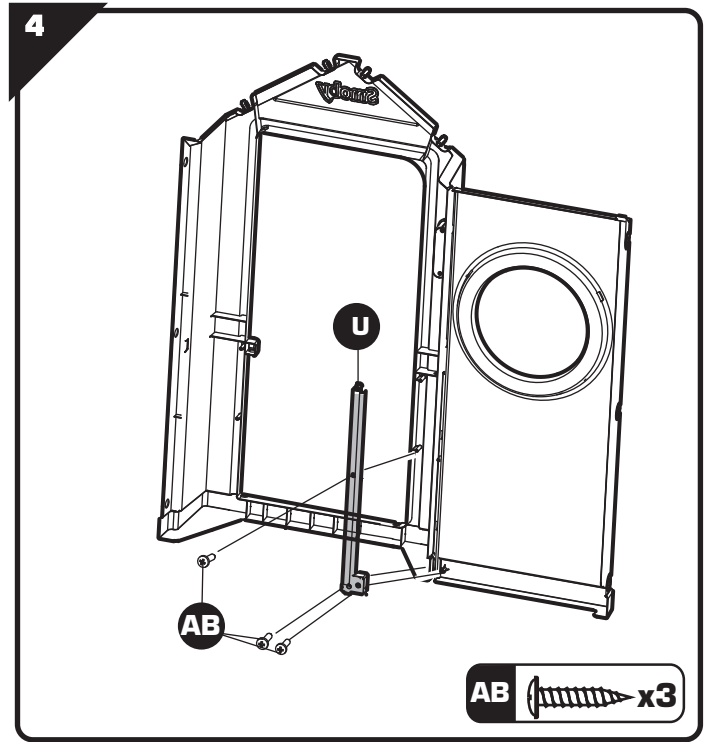
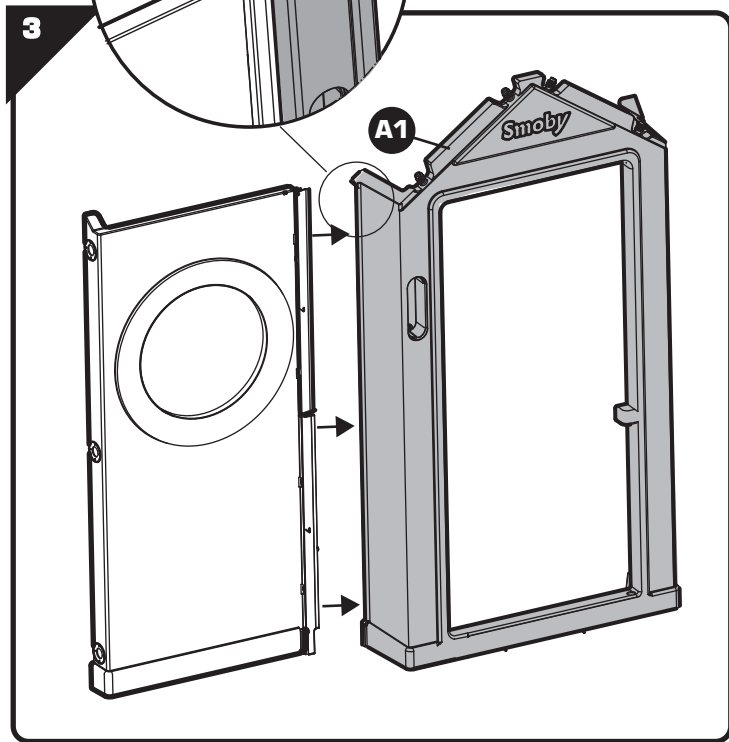
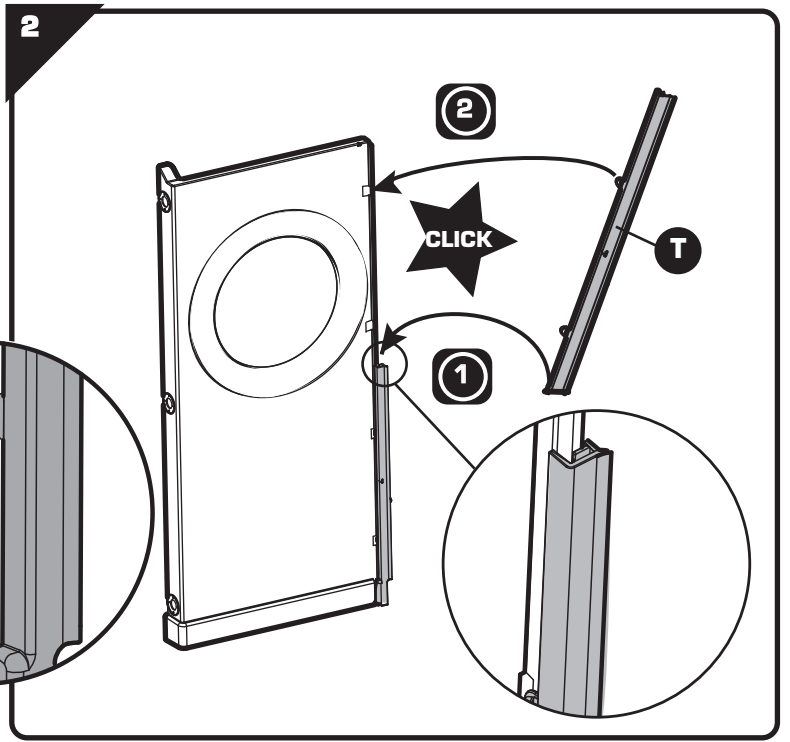
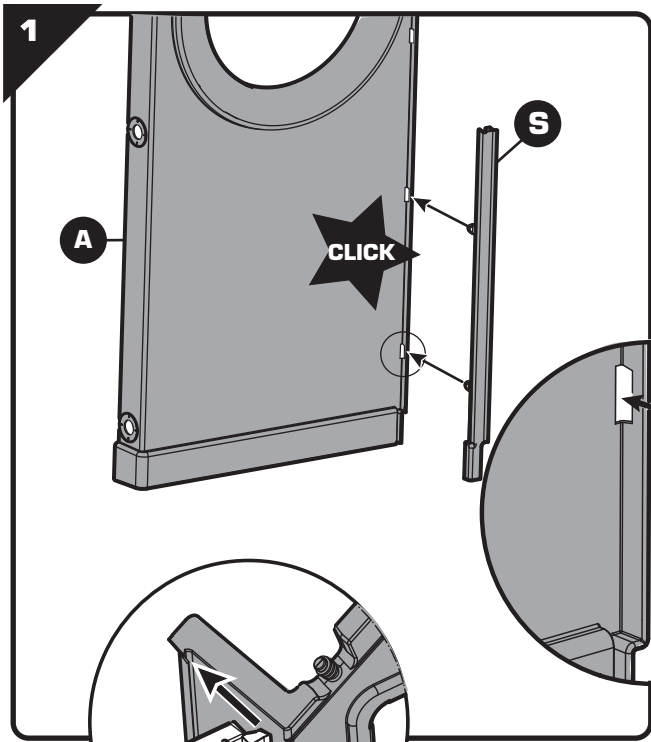

**x2**

AAP2281F P4/20

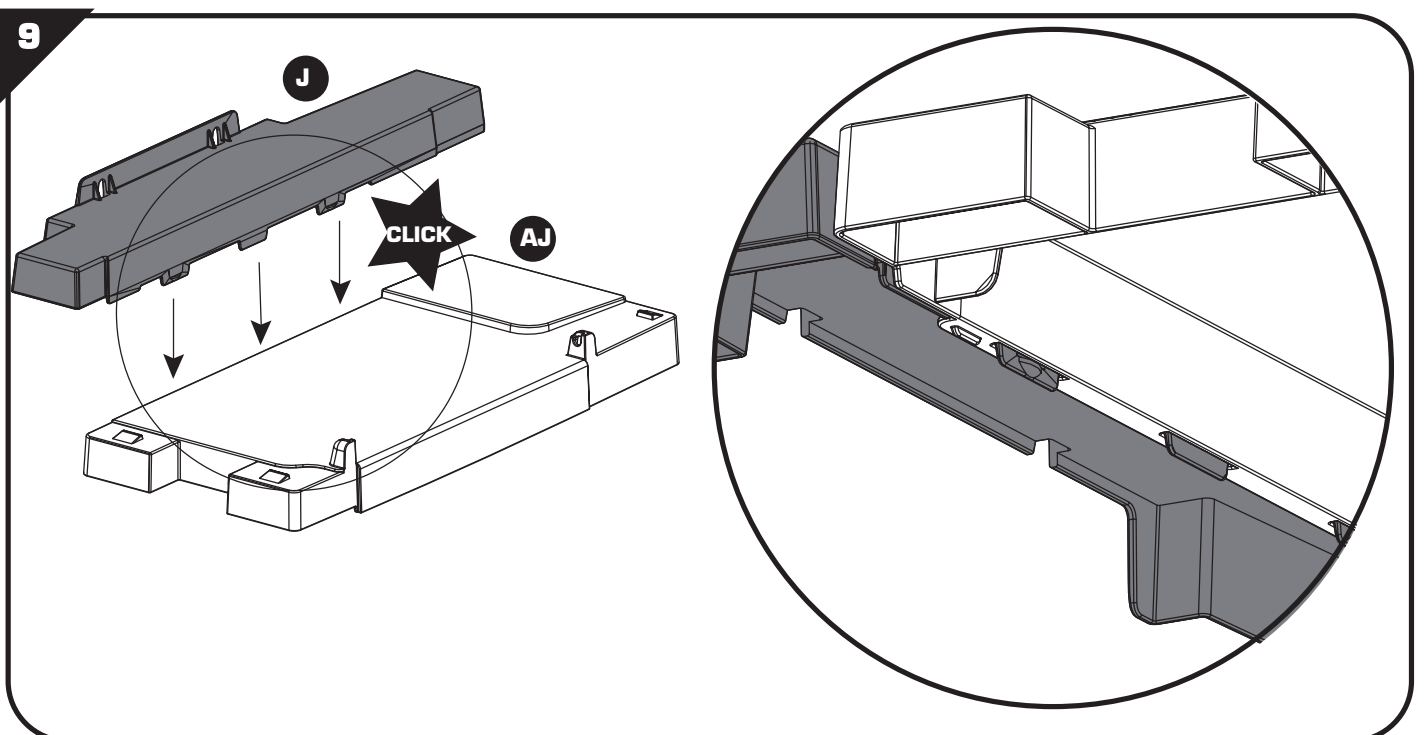
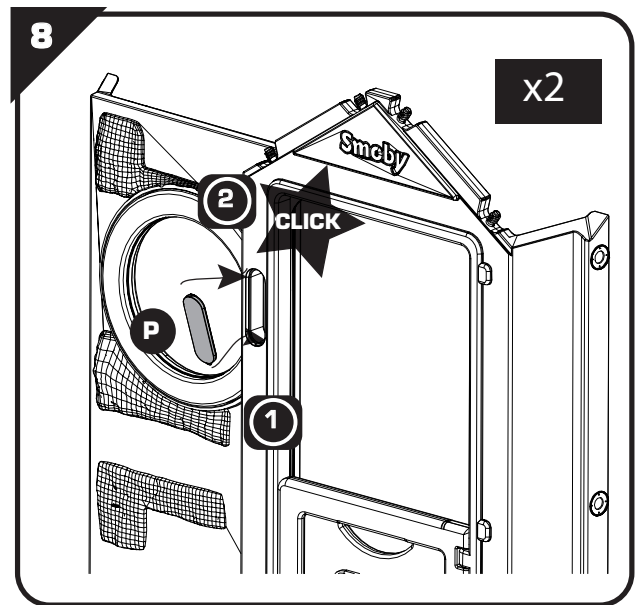
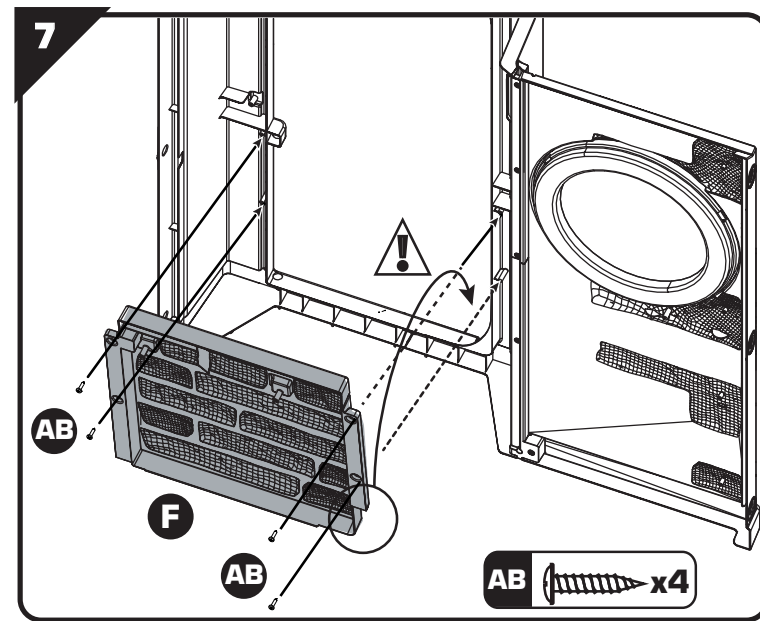
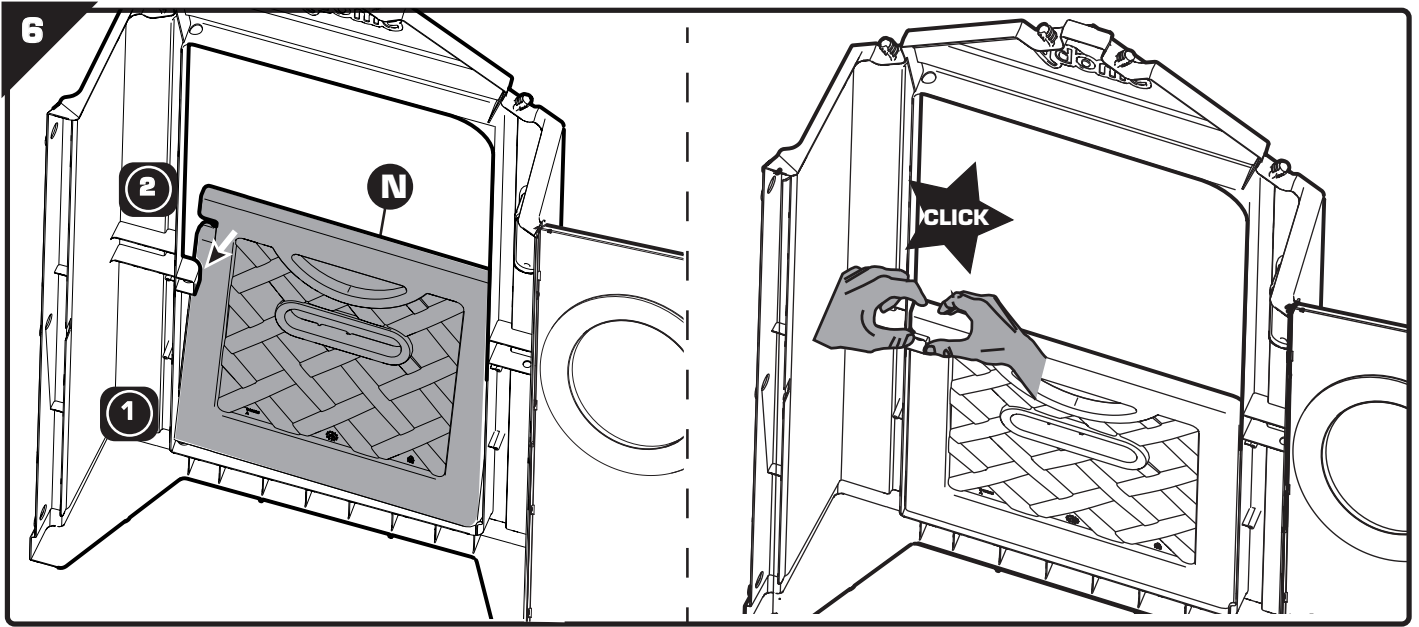

10

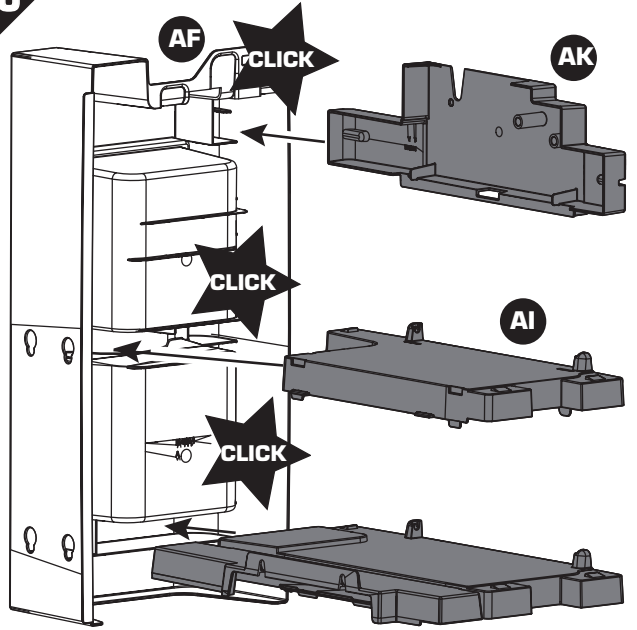

11

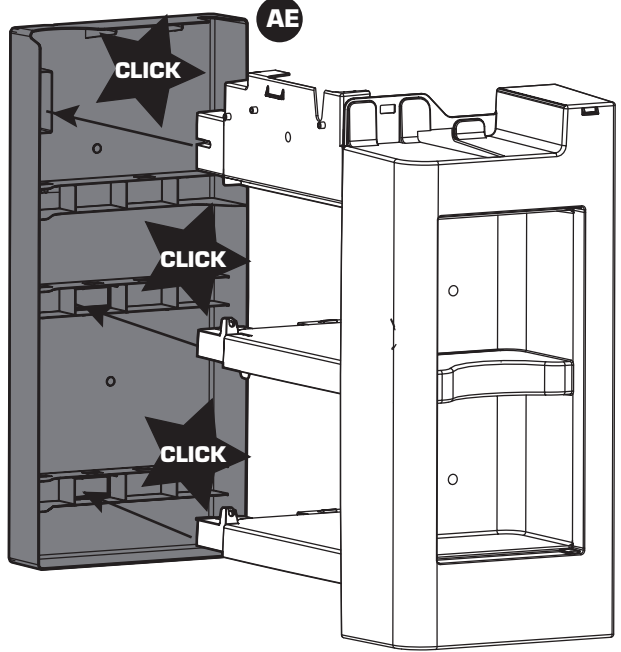

12

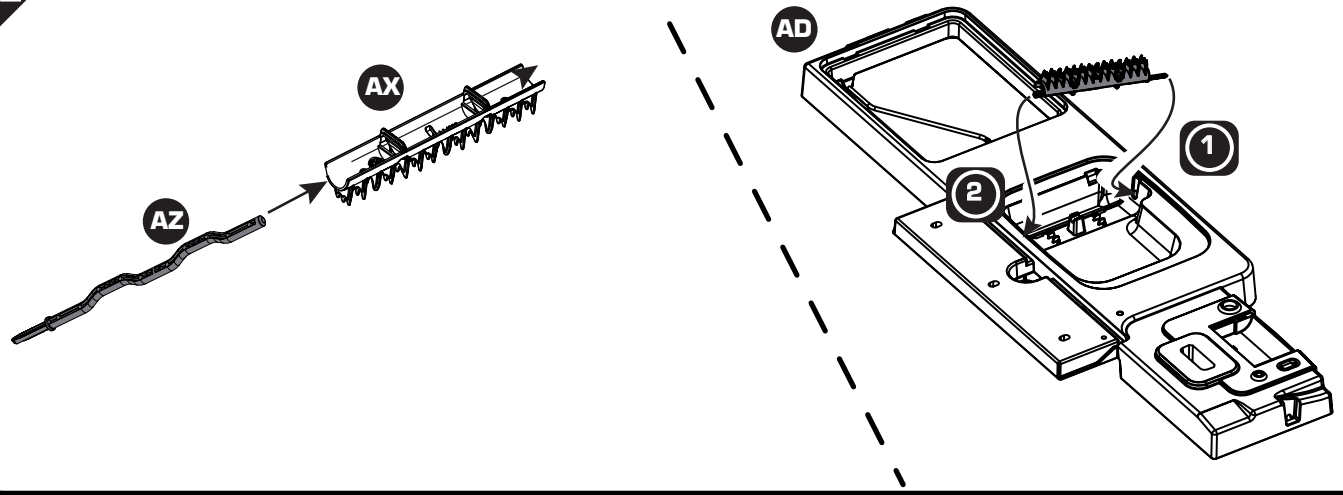

13

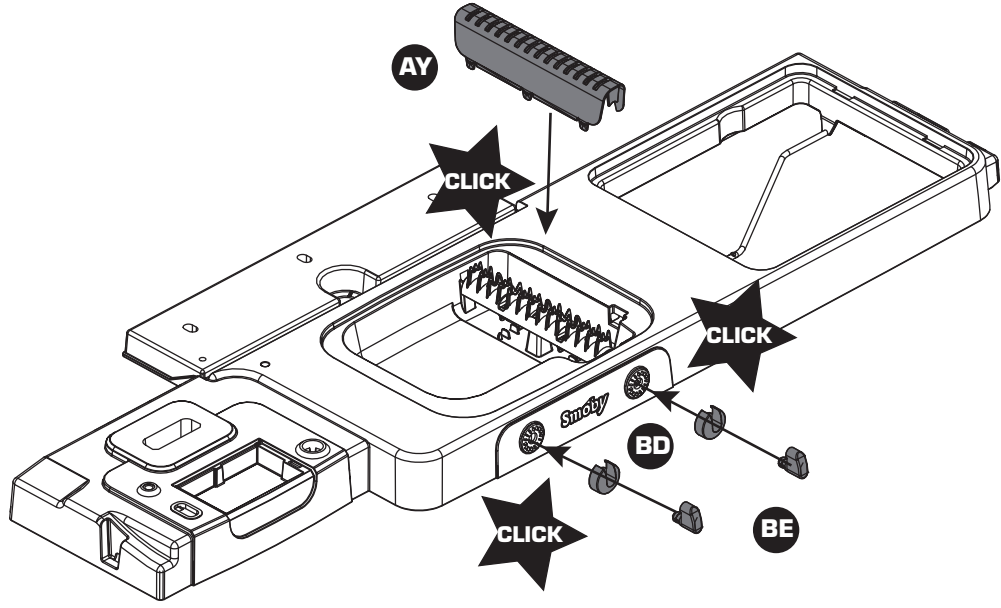

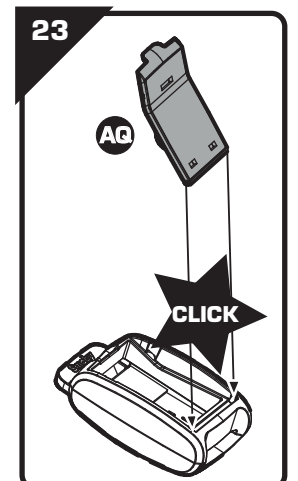
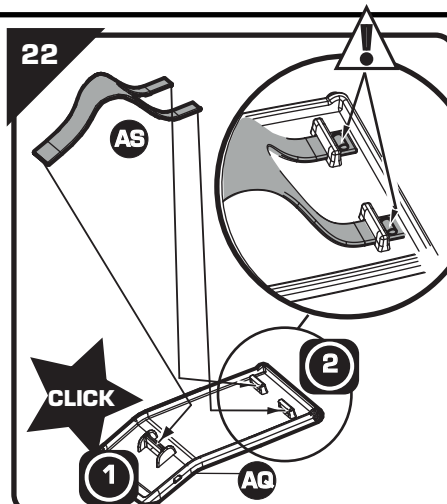
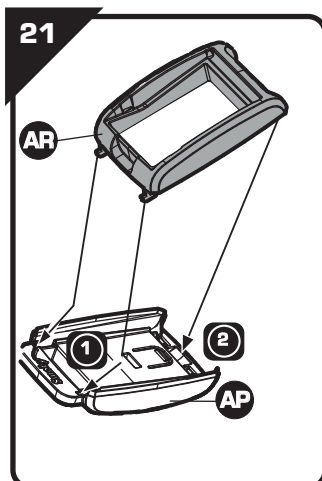
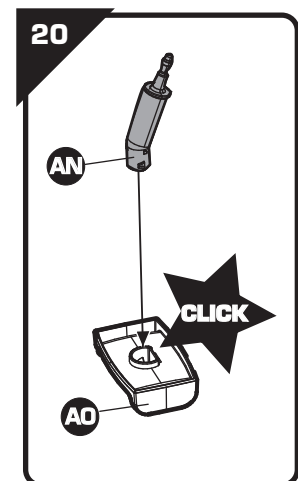
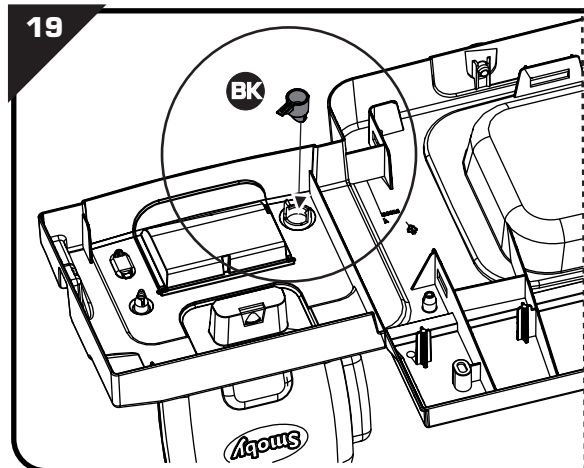
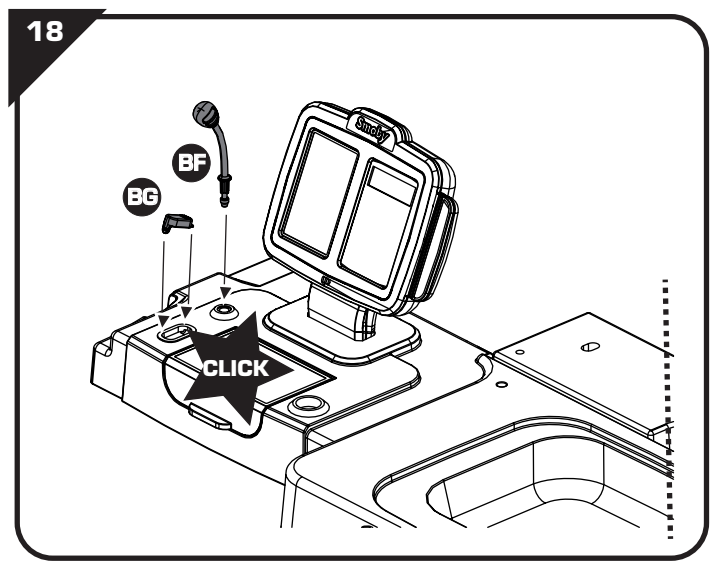
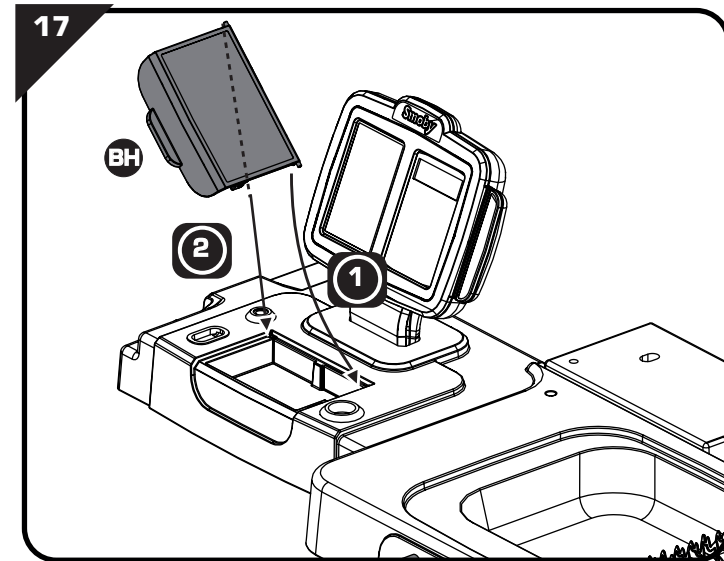
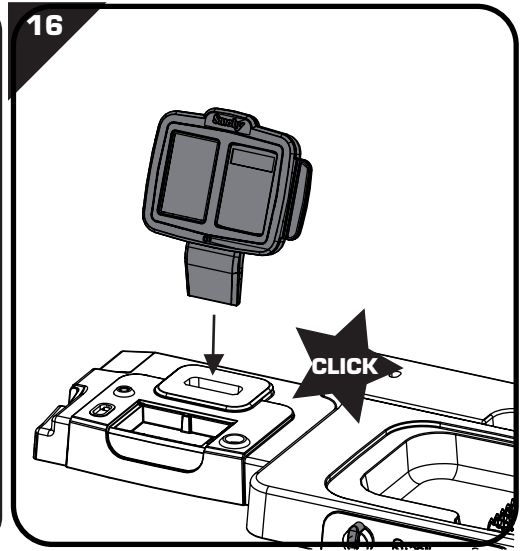
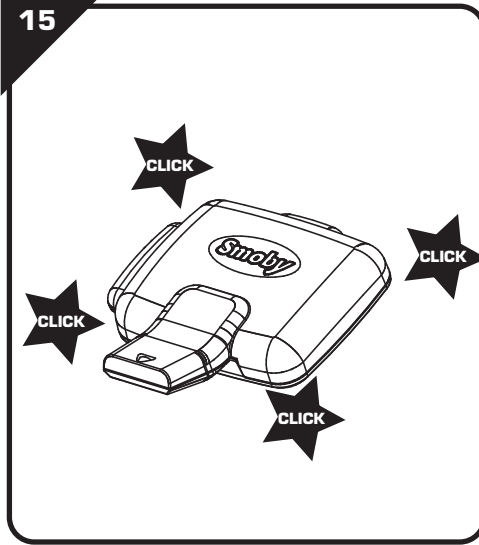
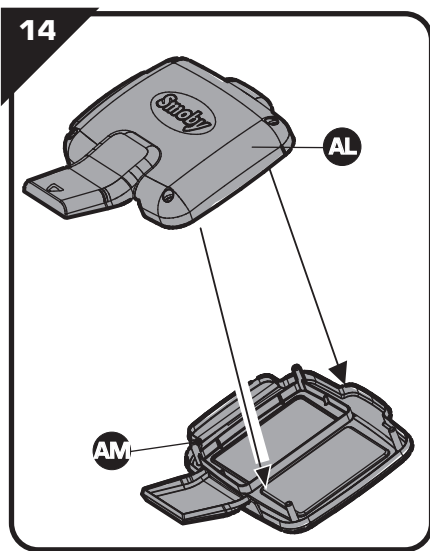

24

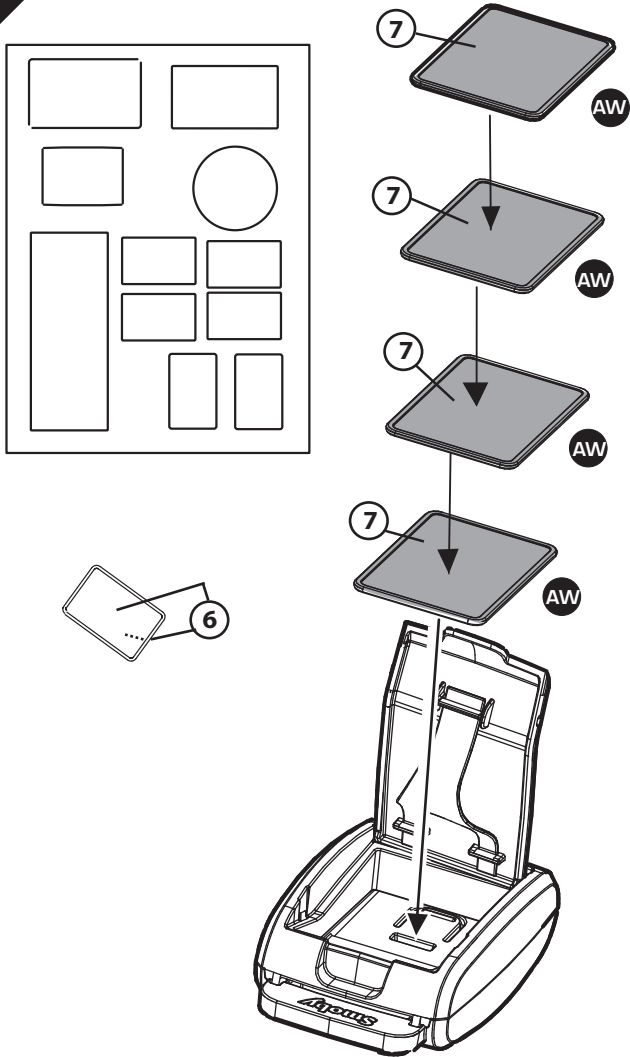

25

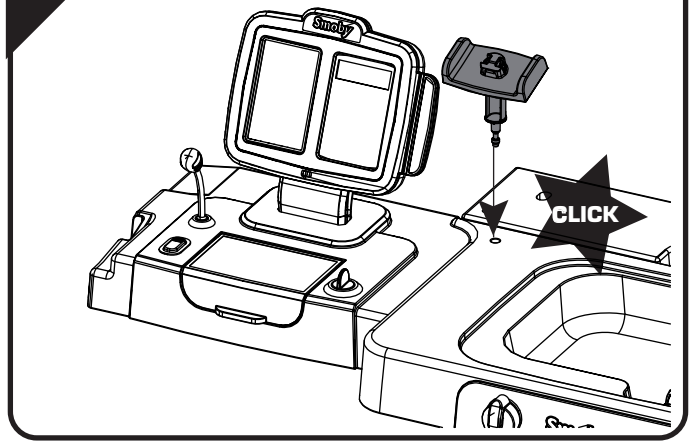

26

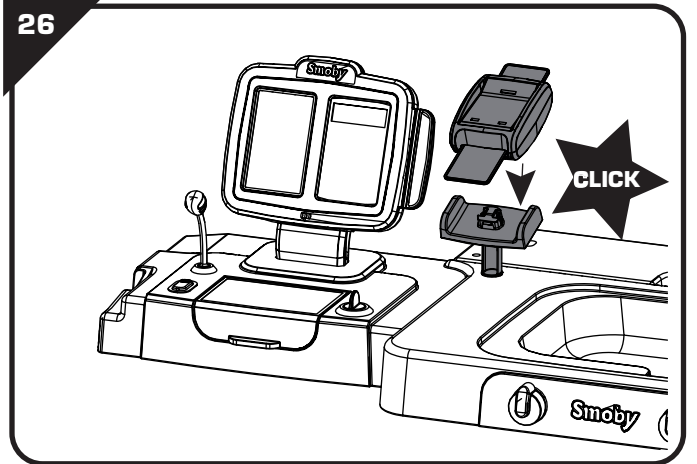

27

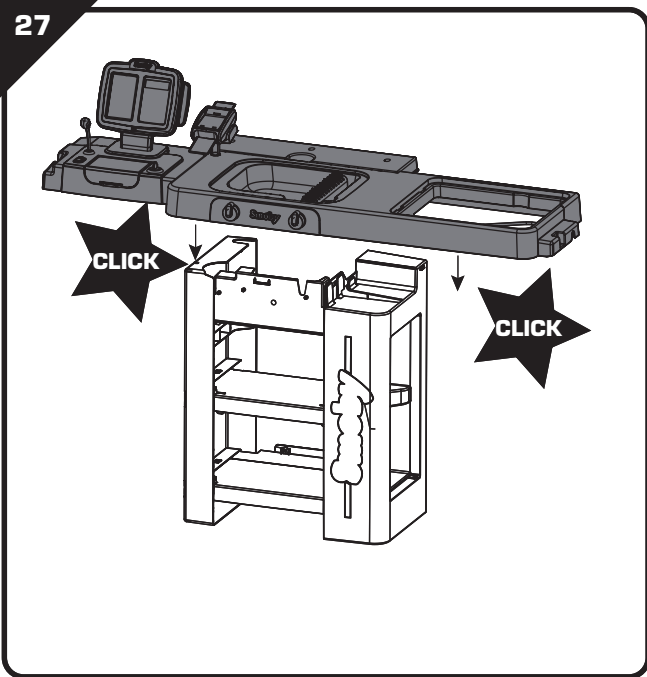

28

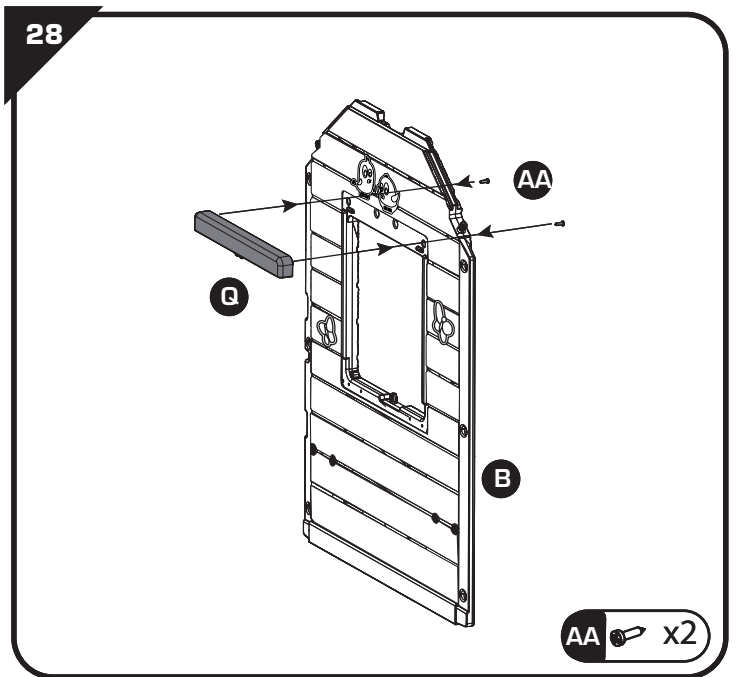



29

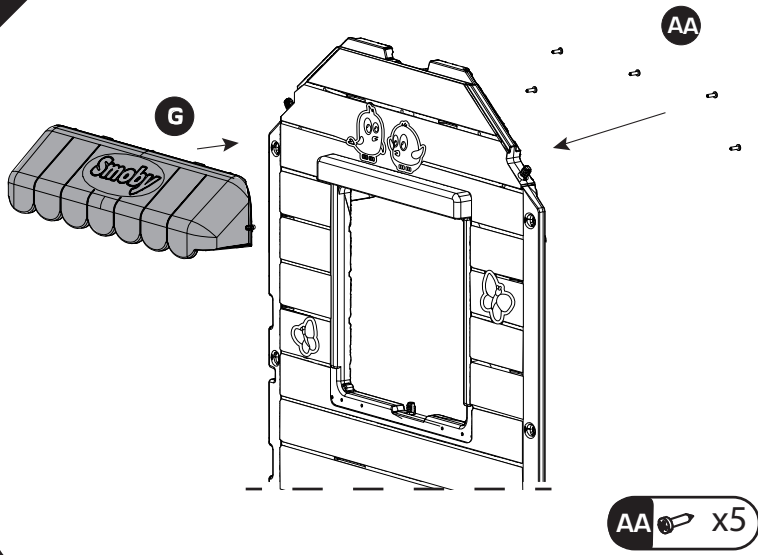

30

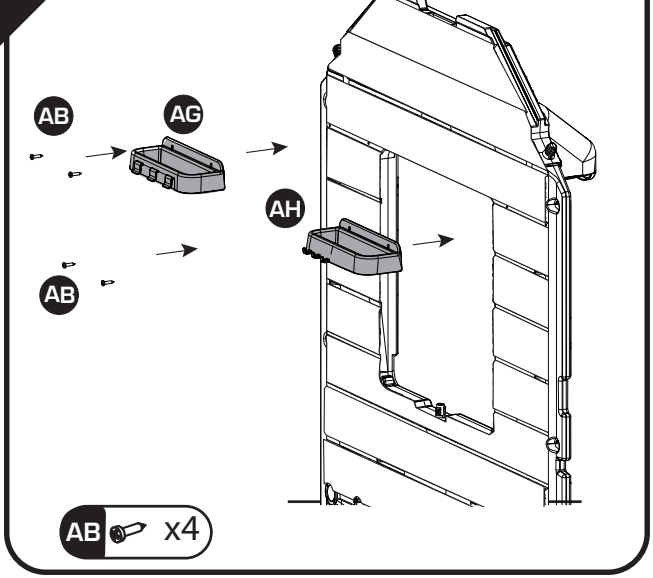

31

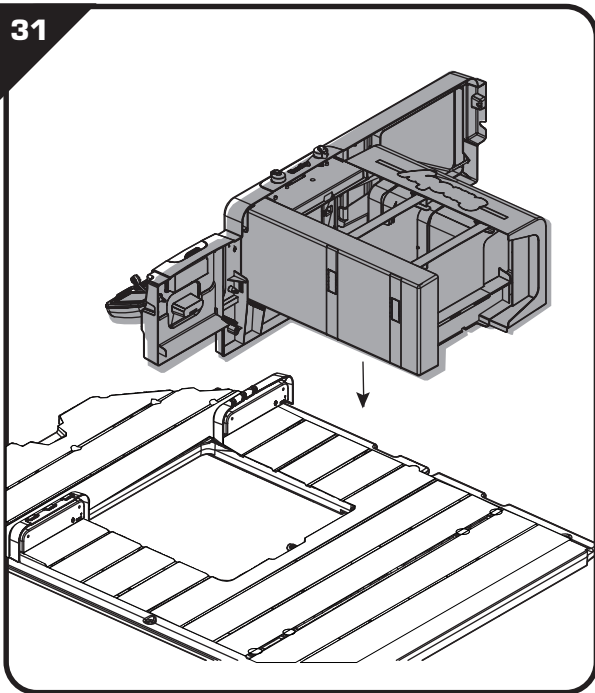

32

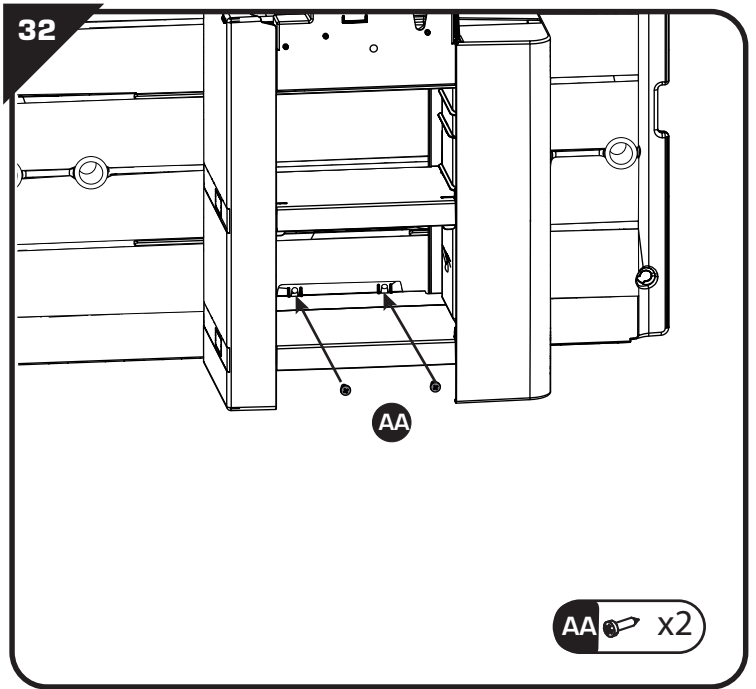

33

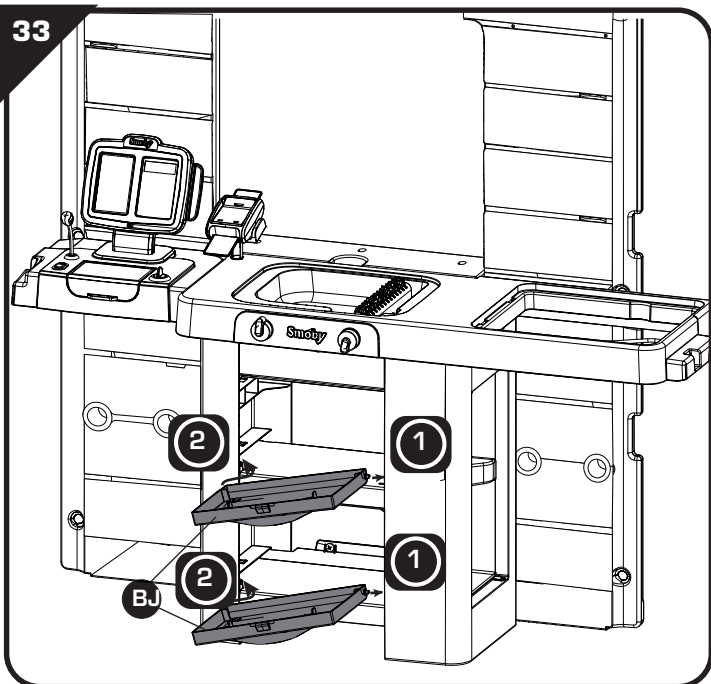

34

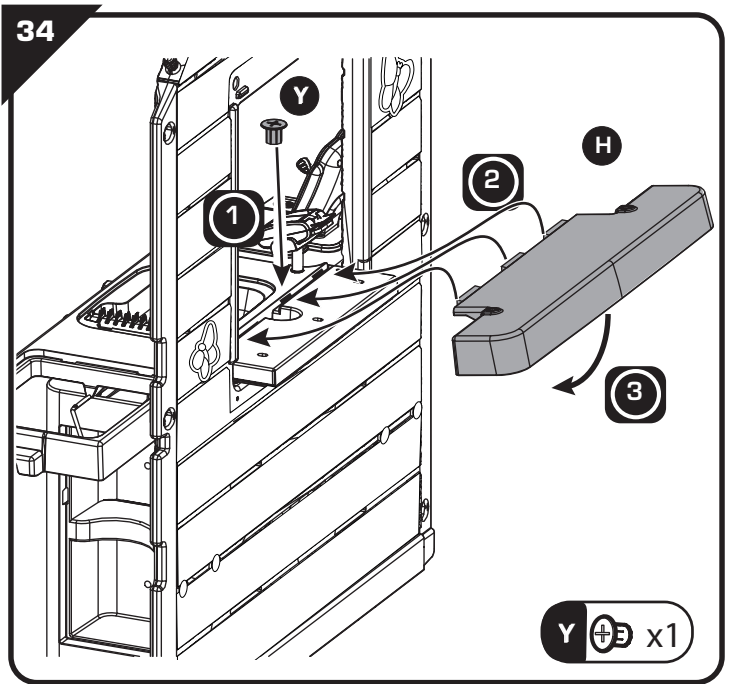

35

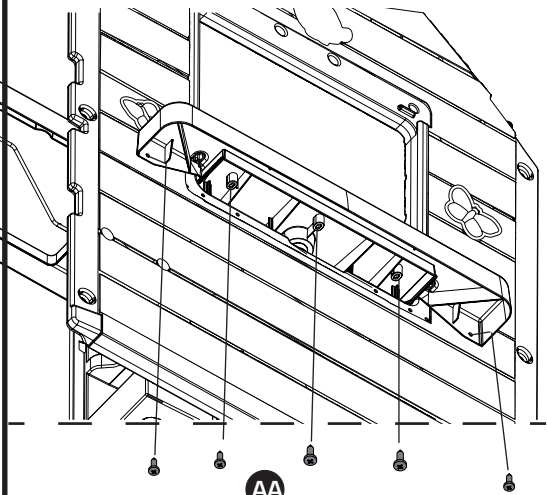

AA

AA x5

36

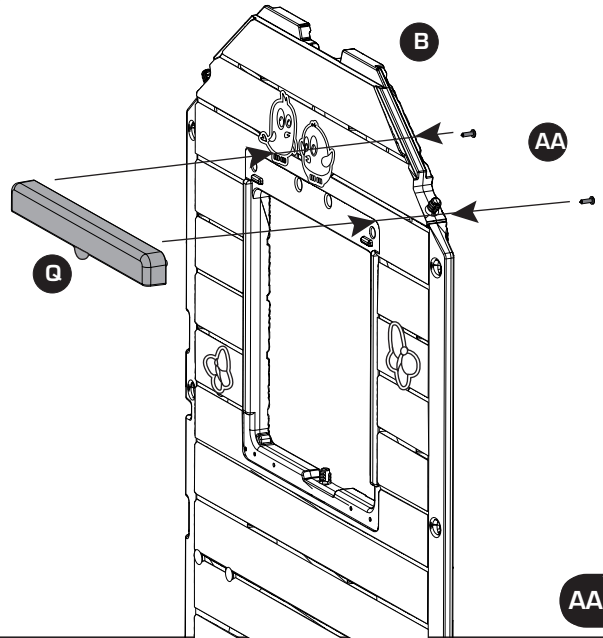

B

AA

Q

AA x2

37

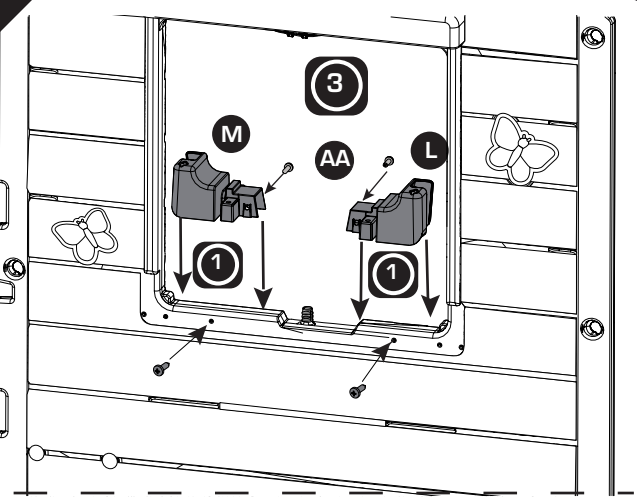

3

M

AA

L

1

1

AA x4

38

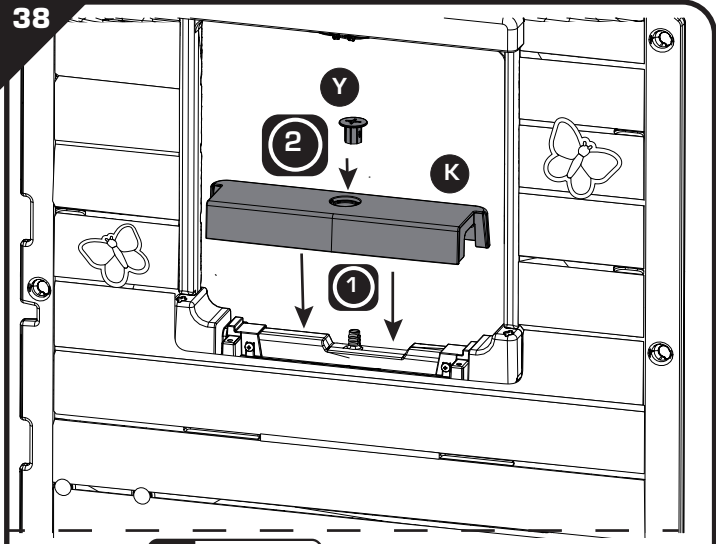

Y

2

K

1

Y x1

39

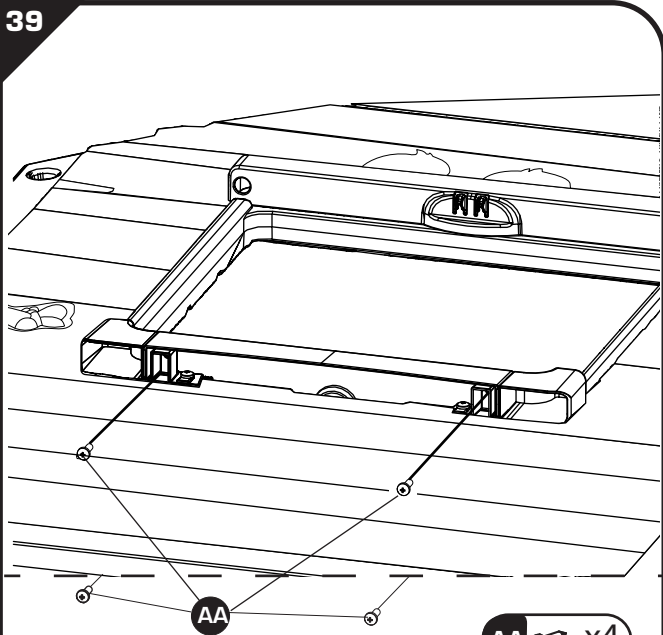

AA

AA x4

40

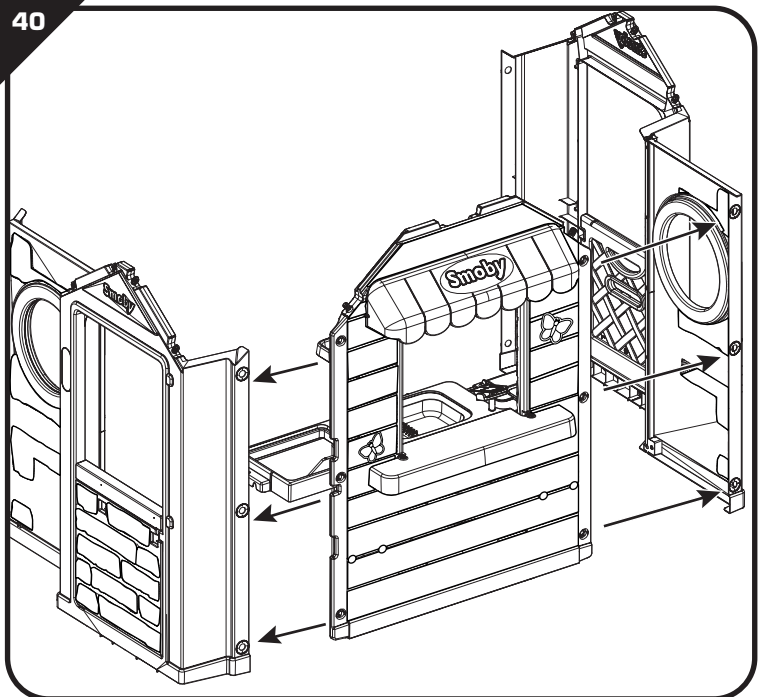

41

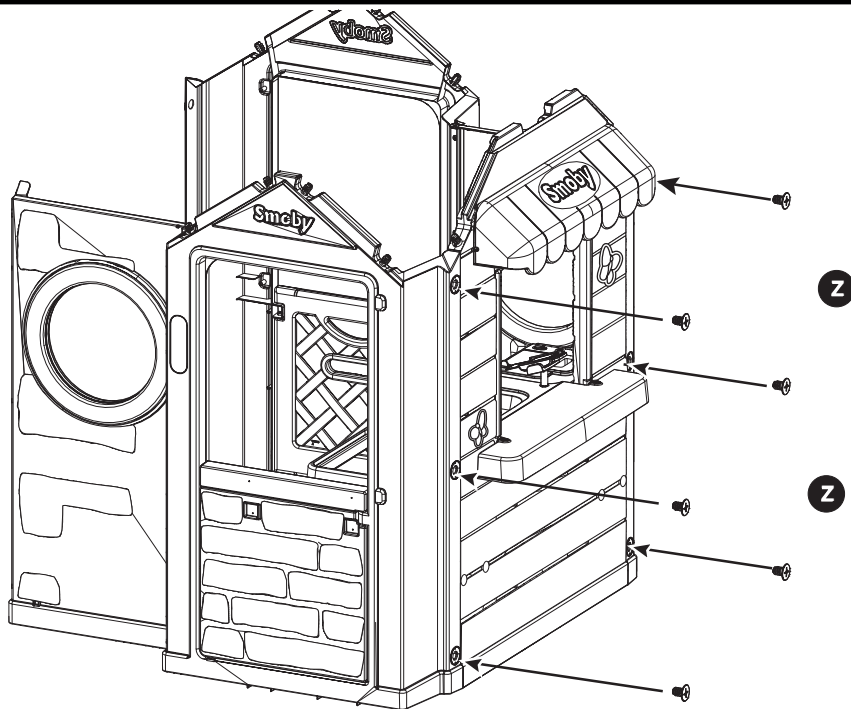

Z  x6

42

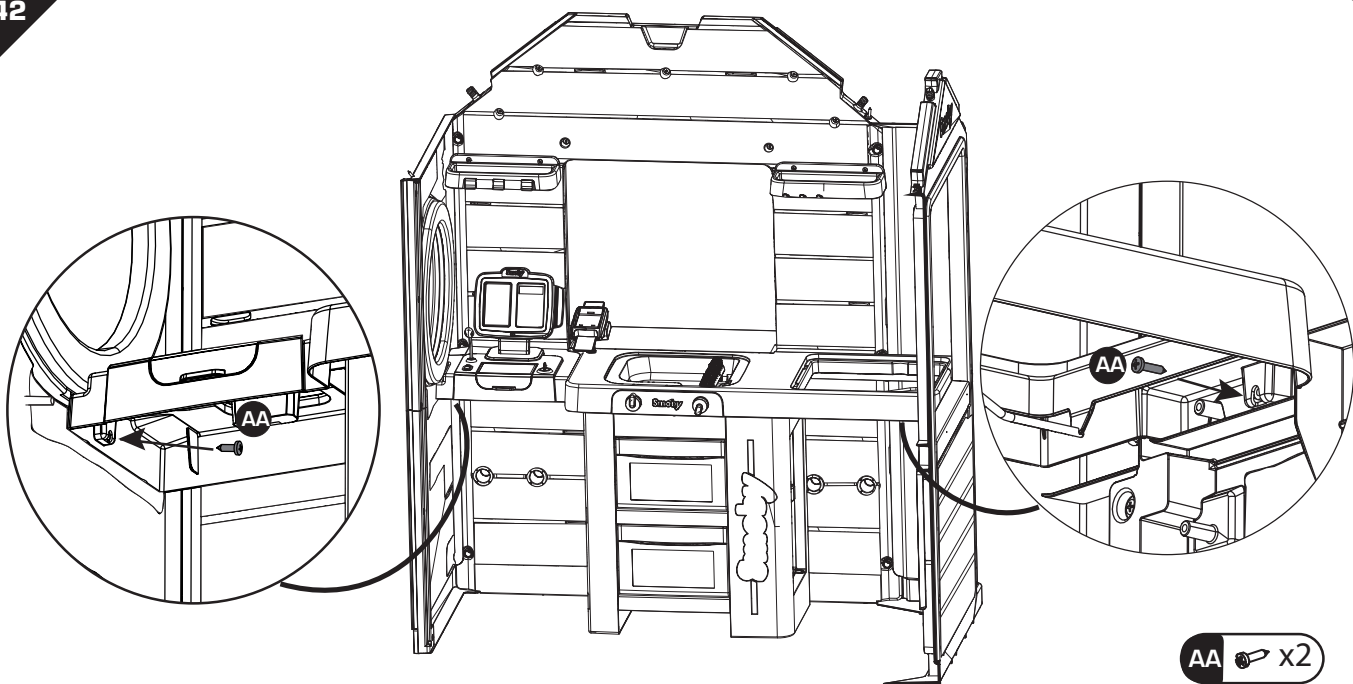

AA  x2

43

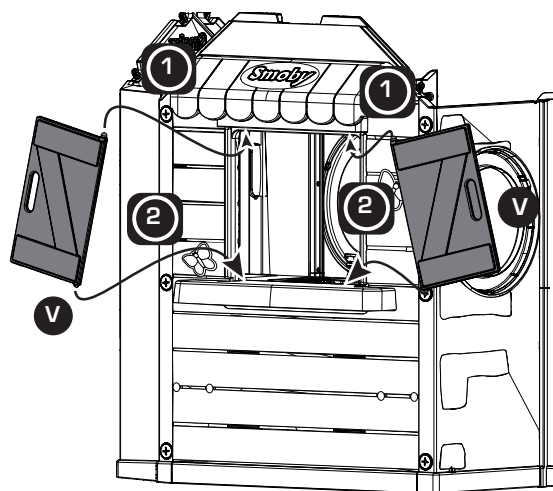
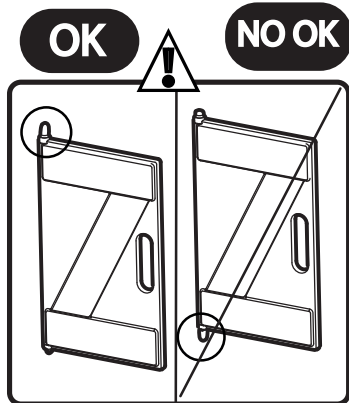

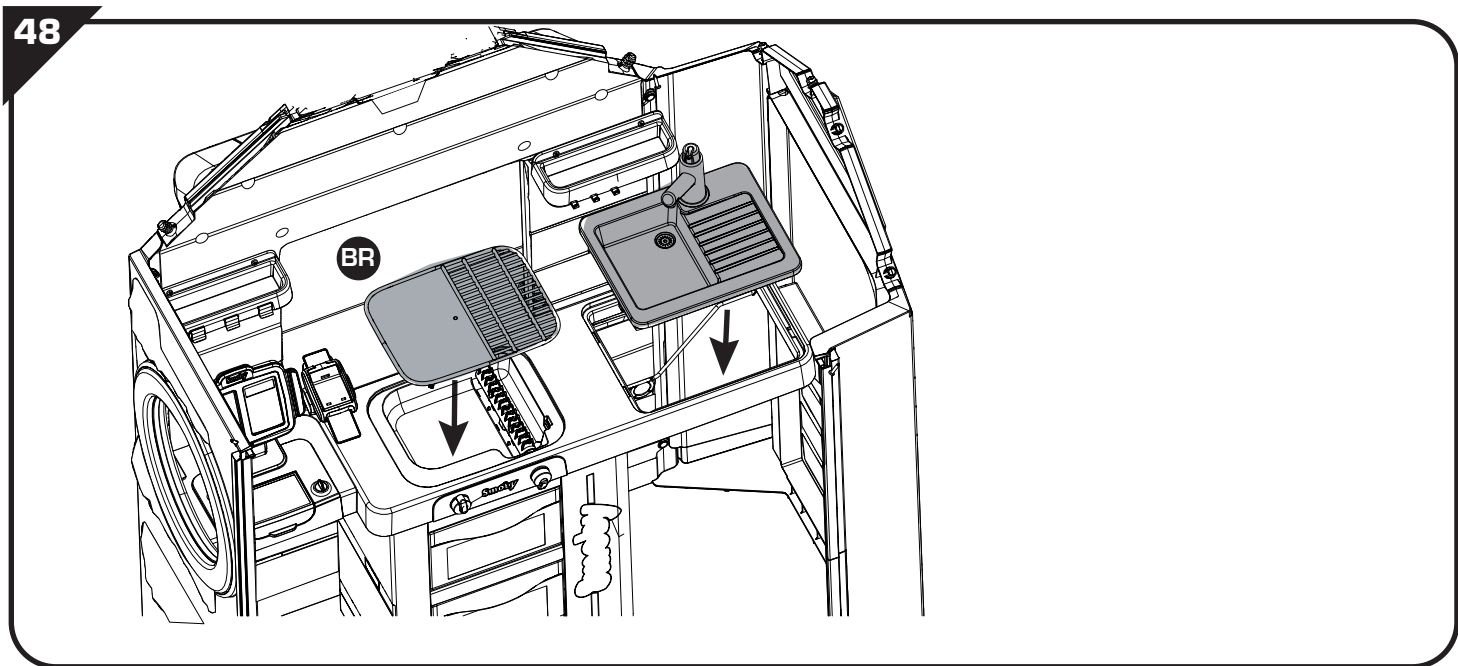
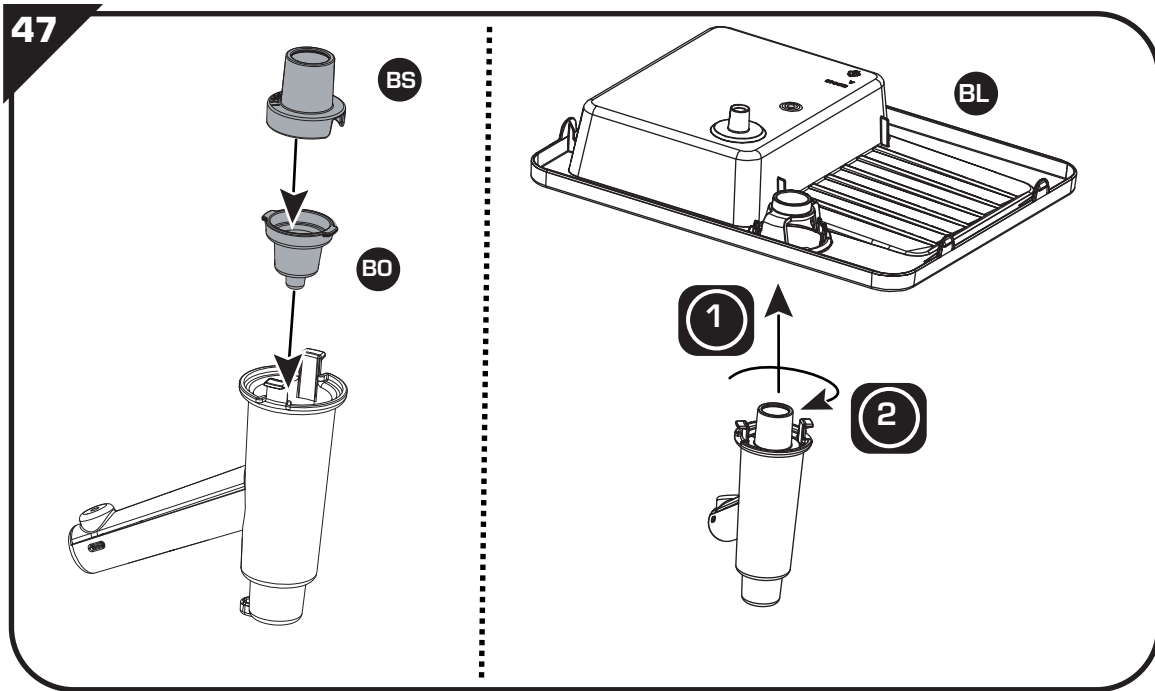
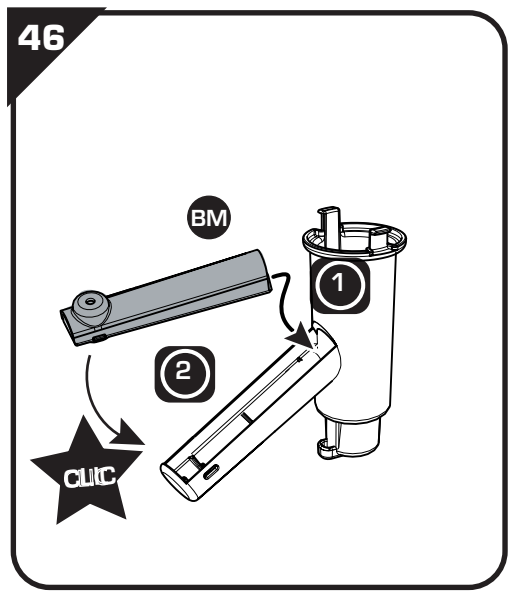
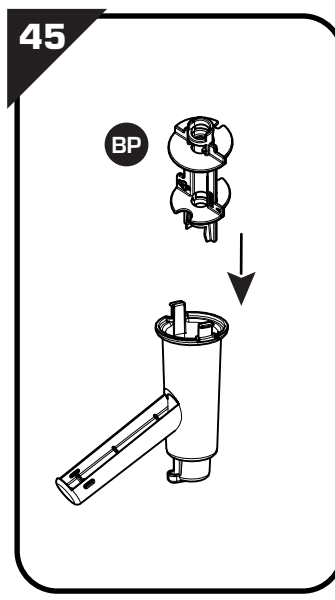
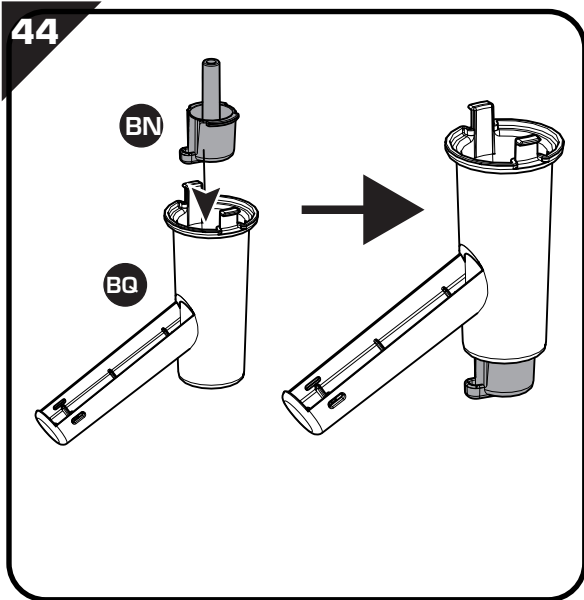

49

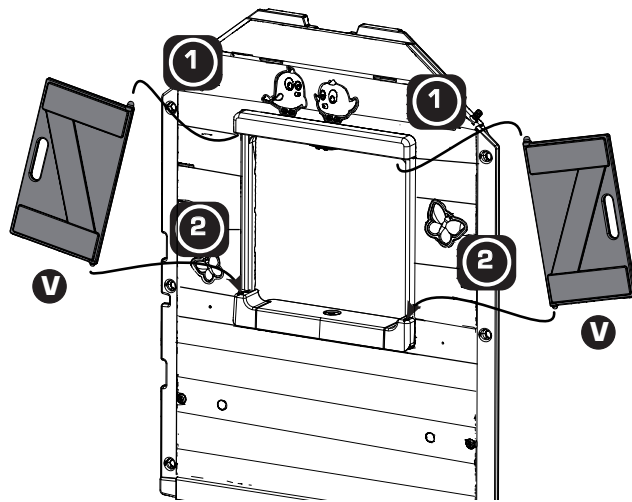
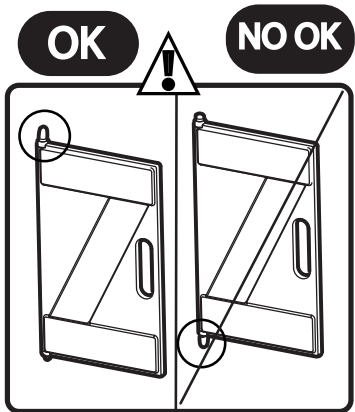

50

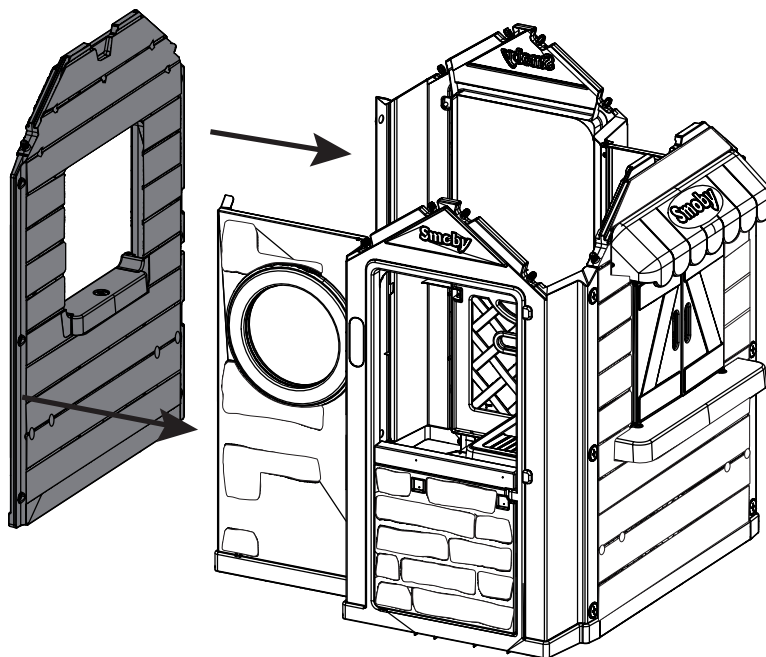

51

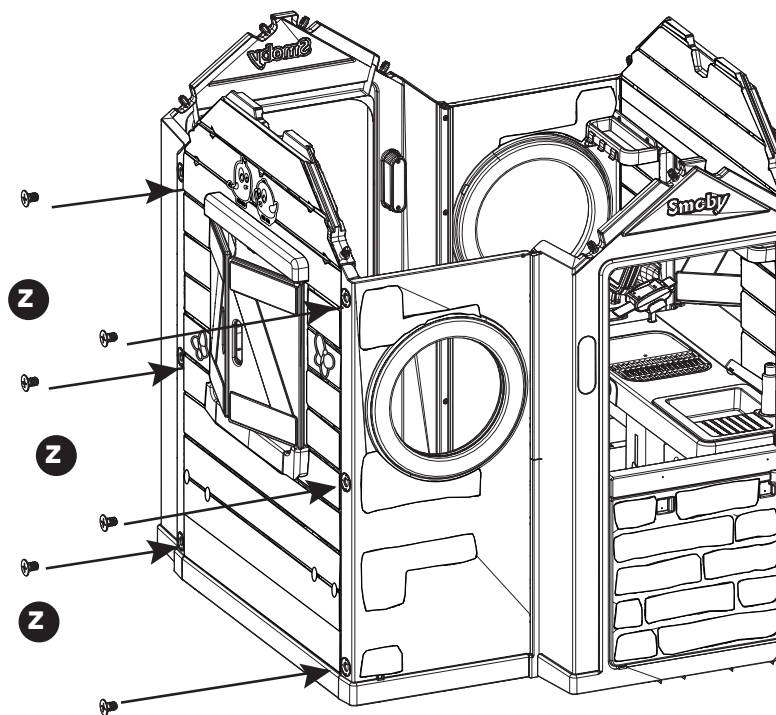

Z  x6

52

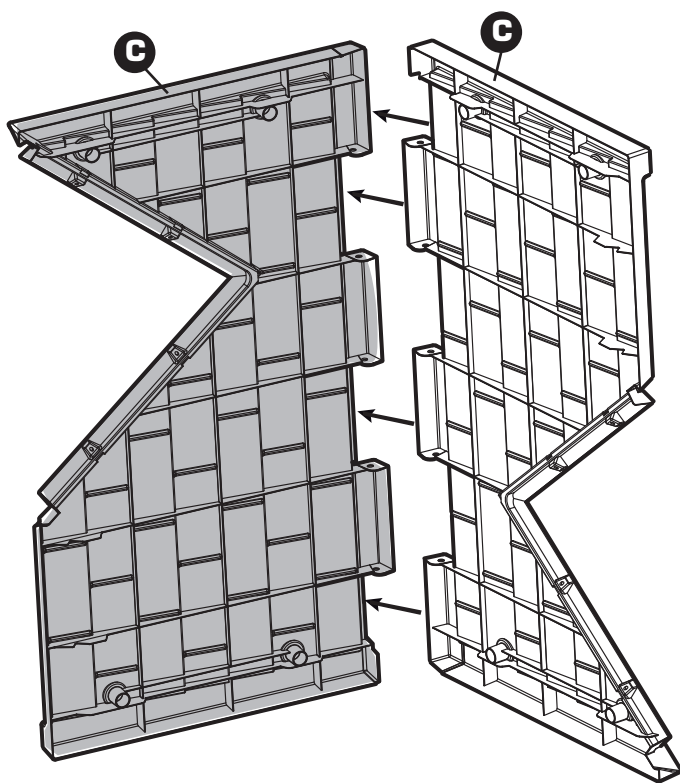

53

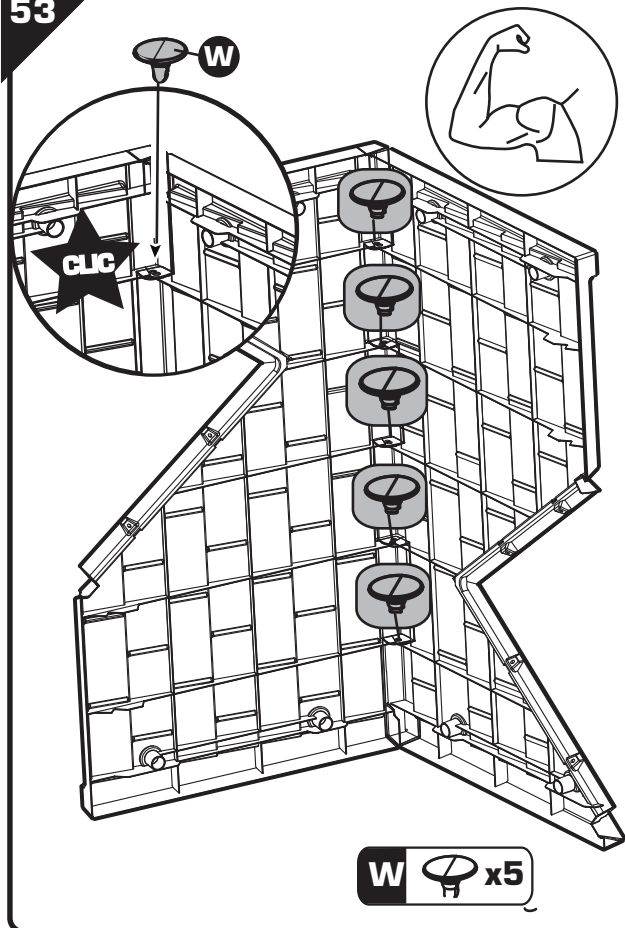

54

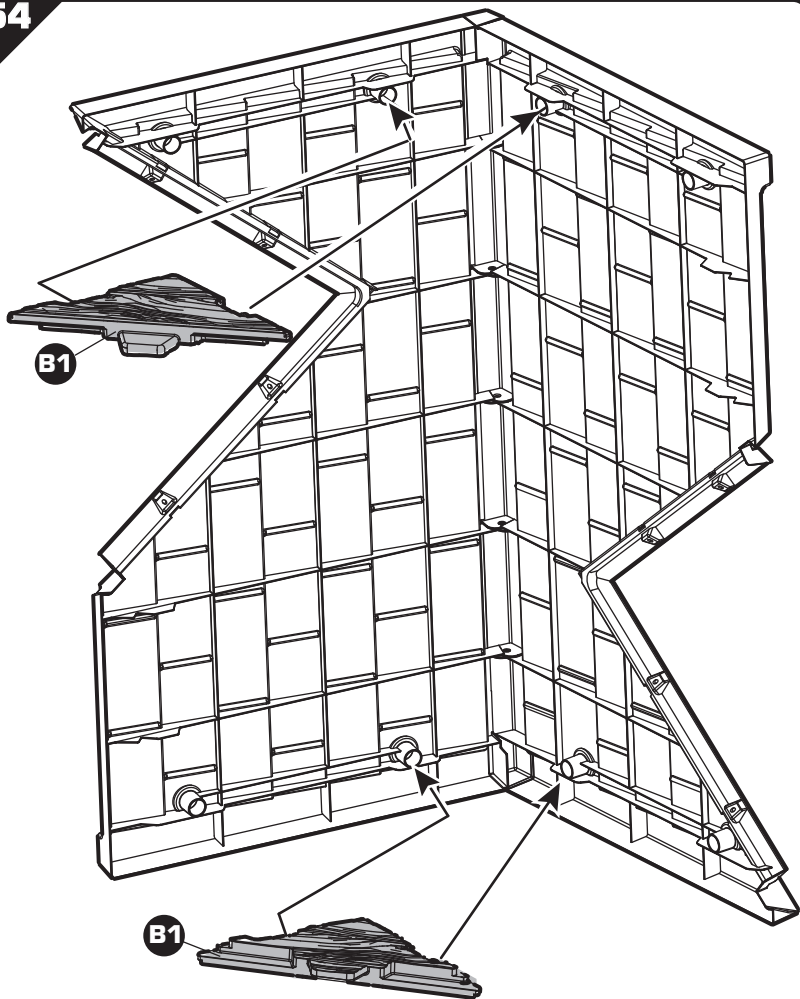

55

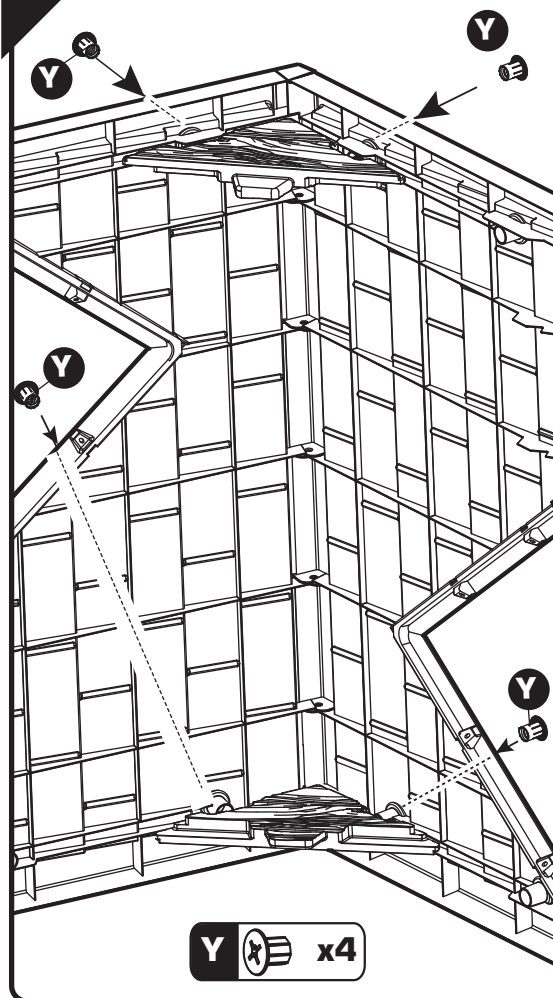

56

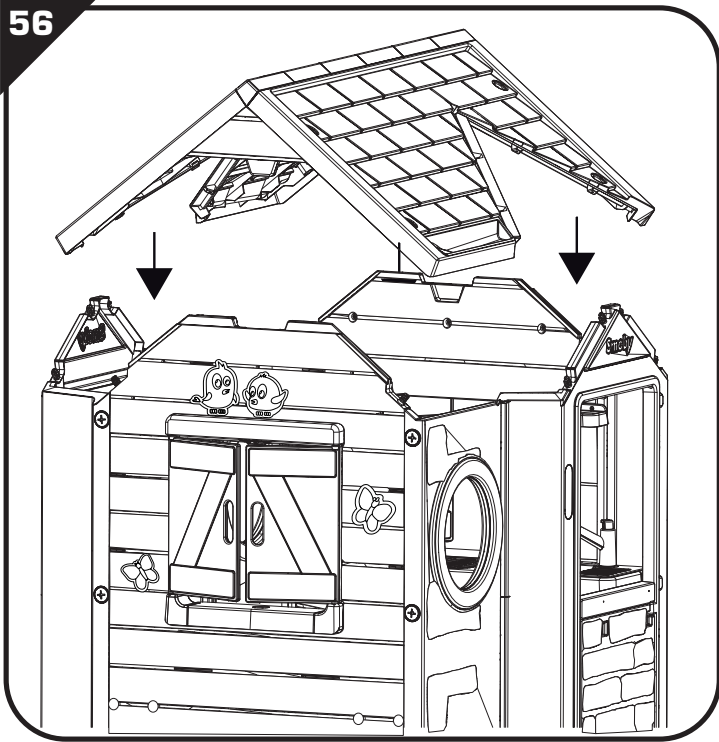

57

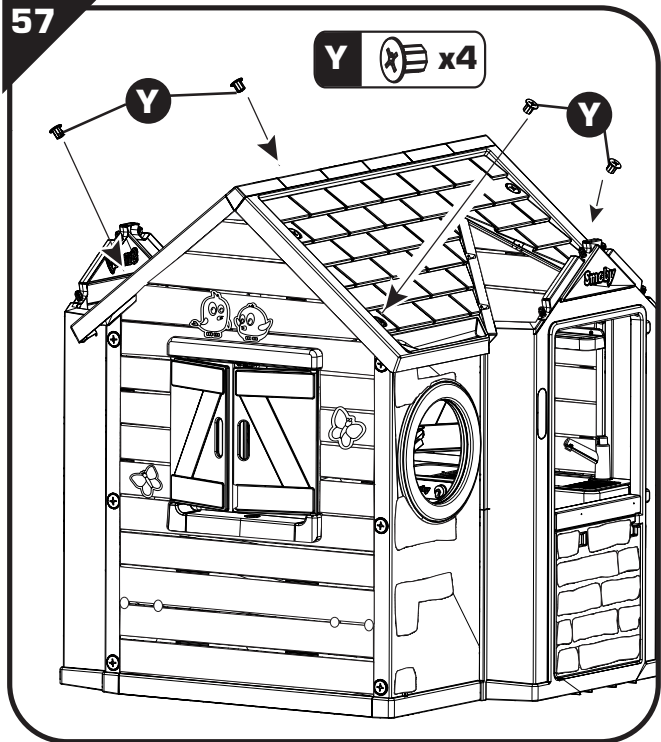

58

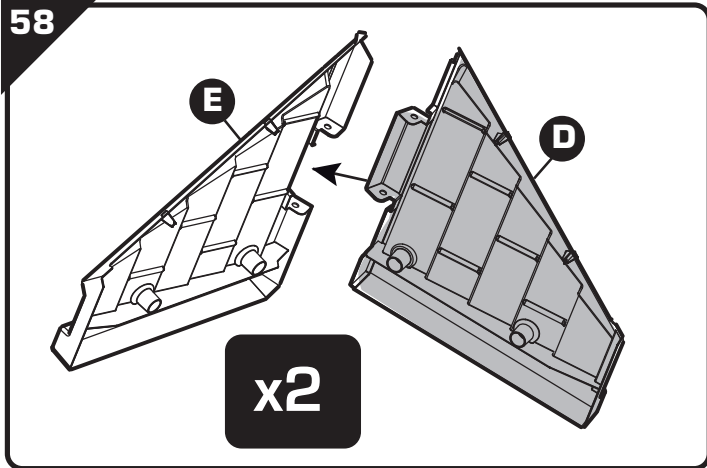

59

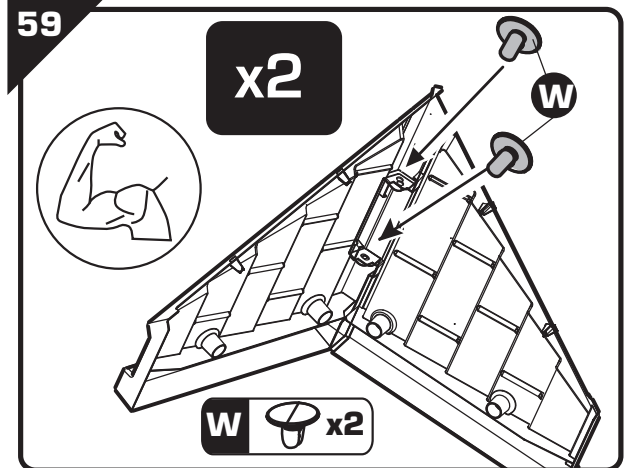

60

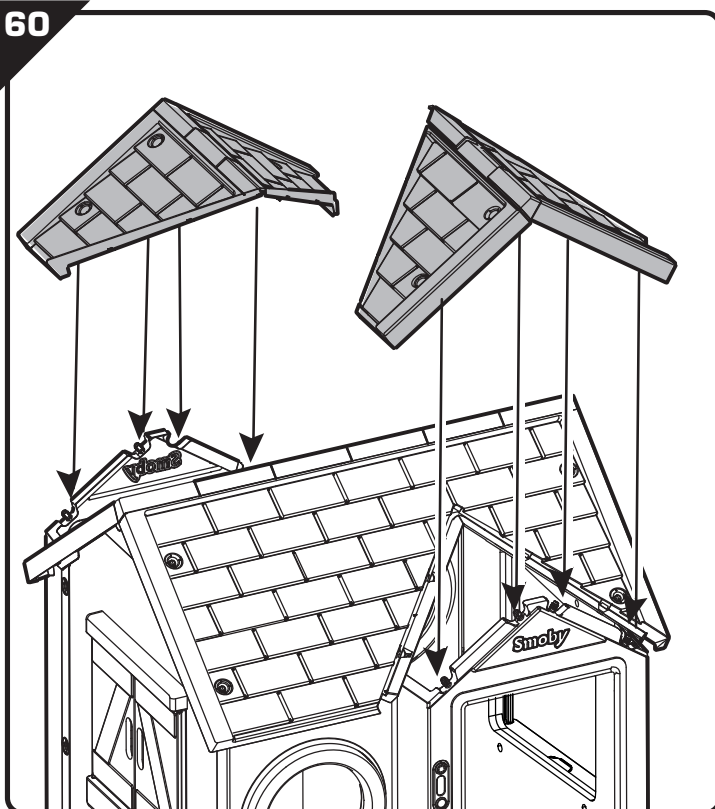

61

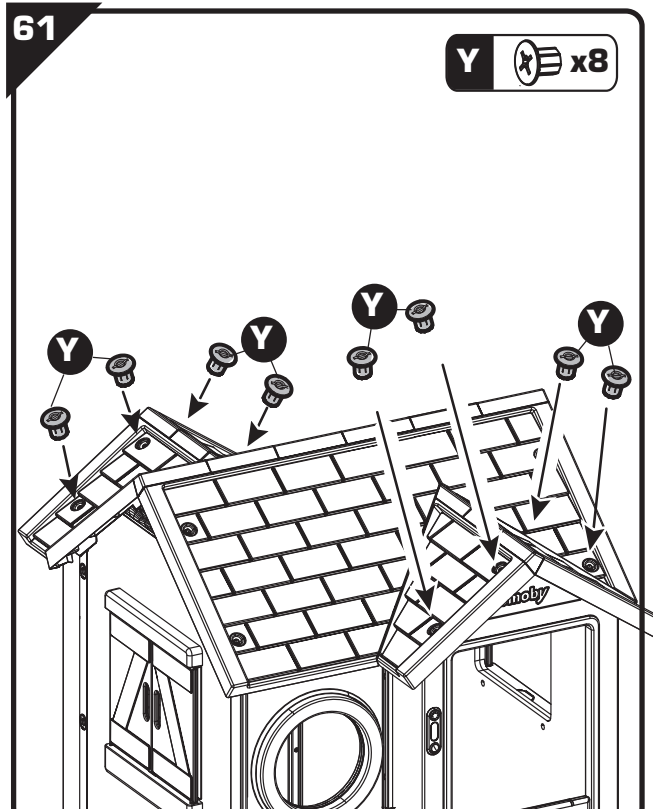

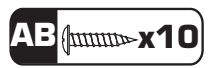
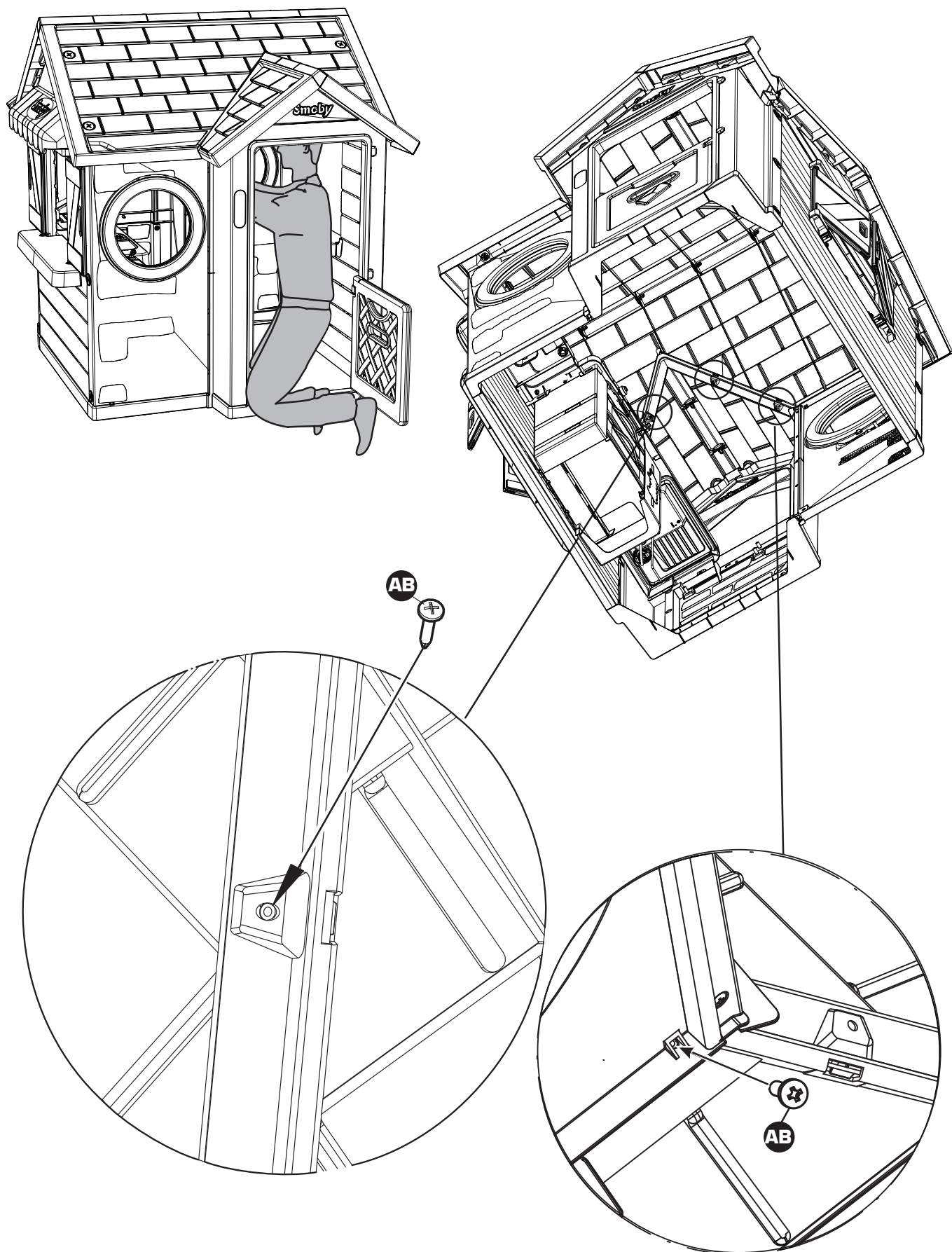



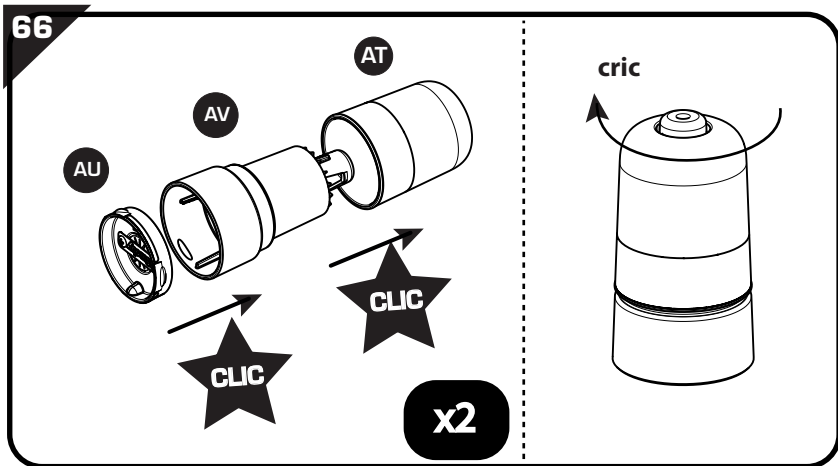
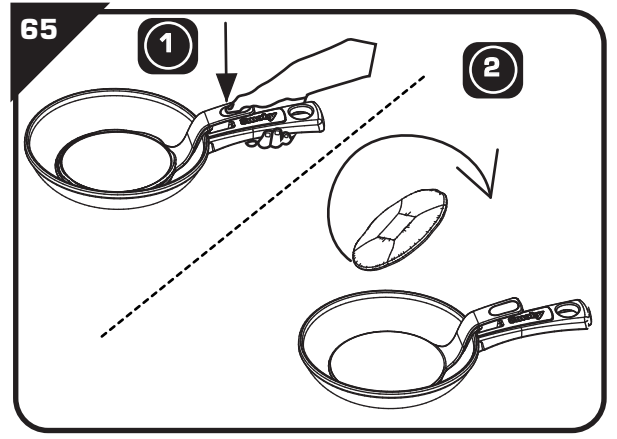
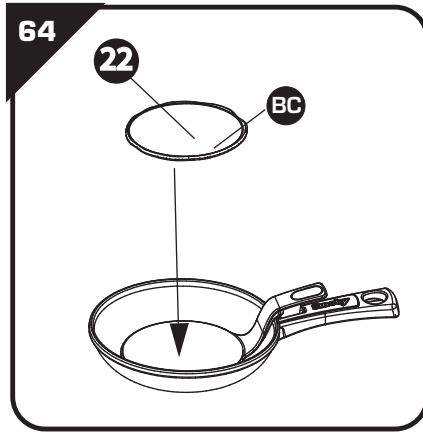
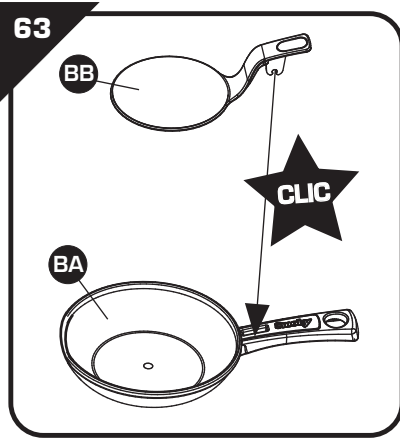

F •Laver soigneusement les accessoires à l'eau claire avant utilisation.  
 GB •Wash the accessories carefully with clean water before use.  
 D •Utensilien vor dem Gebrauch gründlich mit klarem Wasser abwaschen.  
 NL •Was de accessoires grondig met schoon water voor gebruik.  
 E •Lave cuidadosamente los accesorios con agua limpia antes de usarlos.  
 P •Lave cuidadosamente os acessórios com água limpa antes da utilização.  
 I •Lavare accuratamente gli accessori con acqua pulita prima dell'uso.  
 DK •Vask grundigt alt tilbehør i rent vandfør brug.  
 S •Rengör tillbehören försiktigt med rent vatten före användning.  
 FIN •Pese välneet huolellisesti puhtaalla vedellä ennen käyttöä.  
 N •Vask tilbehøret grundig med rent vann før bruk.  
 H •Használat előtt alaposan tisztítsa meg a tartozékokat vízzel.  
 CZ •Před použitím pečlivě umyjte příslušenství čistou vodou.  
 SK •Pred použitím dôkladne umyte príslušenstvo čistou vodou.  
 PL •Przed użyciem starannie umyć akcesoria w czystej wodzie.  
 BG •Измийте грижливо аксесоарите с чиста вода преди употреба.  
 RO •Spălați cu atenție accesoriile cu apă curată înainte de utilizare.  
 GR •Πλύνετε καλά τα εξαρτήματα με καθαρό νερό πριν από τη χρήση.  
 SI •Pred uporabo dodatke temeljito sperite s čisto vodo.  
 HRV •Prije upotrebe temeljito operite pribor čistom vodom.  
 TR •Kullanmadan önce, aksesuarları duru su ile yıkayın.  
 RUS •Перед использованием тщательно промойте принадлежности чистой водой.  
 UA •Ретельно вимийте аксесуари чистою водою перед використанням.  
 ET •Peske tarvikuid enne kasutamist hoolikalt puhta veega.  
 LT •Prieš naudojimą nuplaukite priešus švariui vandeniui.  
 LV •Pirms lietošanas piederumus rūpīgi nomazgājiet ar tīru ūdeni.

•AR اغسل الملحقات بعناية بماء نقي قبل الاستعمال.

**Chef house**

**SMOBY TOYS S.A.S.**

Service après vente / After sales service : [www.smoby.fr](http://www.smoby.fr)  
 95 route du Haut Jura - 39170 Lavans-lès-Saint-Claude / France.

**Smoby**

Assistance consommateurs à nous retourner en cas de problèmes / Consumer assistance: for any problems, return this card /

Verbraucher-Info: Für weitere Auskünfte, senden Sie diese Karte bitte an / Klantenservice: voor inlichtingen, dese kaart naar ons terugsturen /

Atención al consumidor: para cualquier información, enviar esta tarjeta. / Assistenza per il consumatore: per informazioni, rispedire la presente cartolina.

NOM / NAME: \_\_\_\_\_

PRENOM / SURNAME: \_\_\_\_\_

RUE / STREET: \_\_\_\_\_

VILLE / TOWN: \_\_\_\_\_

CODE POSTAL / POSTAL CODE: \_\_\_\_\_

PAYS / COUNTRY: \_\_\_\_\_

N°TEL: \_\_\_\_\_

EMAIL: \_\_\_\_\_

Description du motif de la réclamation / Cause for complaint / Grund der Beanstandung / Omschrijving van de reden van de klacht / Detalle el motivo de su reclamación / Descizione del motivo del reclamo:

Manquant / Missing / Fehlende Teile / Tekort / Faltante / Mancante.

Cassé / Broken / Gebrochen / Gebroken / Rotura / Rotto.

Commentaires / Comments / Bemerkung / Opmerkingen / Comentarios / Commenti.

Ref:
Couleurs/Colors:
N° Notice / IS Number : <b>AAP2281F</b>

N°:  N°:  N°:  N°:  N°:  N°:  N°:   
 Qté: ..... Qté: ..... Qté: ..... Qté: ..... Qté: ..... Qté: ..... Qté: .....



**⚠ WARNING:**  
 Never allow a child to play without adult supervision.

**⚠ WARNING:**  
 Toy must be assembled by an adult, as it contains hazardous points or edges. A sharp tool shall be used.





