

Smoby

F -ATTENTION!
 GB -WARNING!
 D -ACHTUNG!
 NL -WAARSCHUWING!
 E -¡ADVERTENCIA!
 P -ATENÇÃO!
 I -AVVERTENZA!
 DK -ADVARSEL!
 SE -VARNING!
 FIN -VAROITUS!
 N -ADVARSEL!
 H -FIGYELMEZTETÉS!
 CZ -UPOZORNĚNÍ!
 SK -UPOZORNENIE!

PL -OSTRZEŻENIE!
 BG -ВНИМАНИЕ!
 RO -AVERTISMENT!
 GR -ΠΡΟΕΙΔΟΠΟΙΗΣΗ!
 SI -OPROZORILO!
 HRV -UPOZORENJE!
 TR -UYARI!
 UA -УВАГА!
 EST -HOIATUS
 LT -DĖMESIO!
 LV -UZMANĪBU!
 !تنبيه -AR

+18

mois
 months
 Monate
 maanden
 meses
 meses
 mesi
 måneder
 månader

kuukauden
 måneder
 hónapban
 mesícú
 mesiacov
 miesiecy
 meceça
 luni
 μηνών

mesecev
 mjeseći
 ayda
 місяців
 kuud
 mėn
 mėneši
 شهر



x1

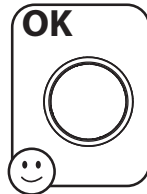
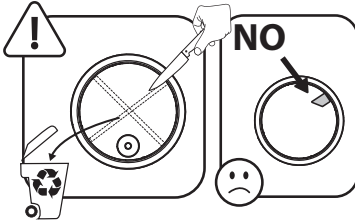
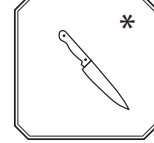
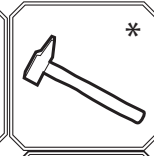
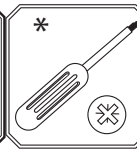

* F -Outils non fournis
 GB -Tools not provided.
 D -Werkzeug nicht inbegriffen
 NL -Gereedschap niet inbegrepen
 E -Herramientas no incluidas
 P -Ferramentas não fornecidas.
 I -Utensili non forniti
 DK -Værktøj medfølger ikke.
 S -Verktøy ingår inte.
 FIN -Ei sisällä työkaluja

N -Verktøy følger ikke med
 H -A szerszámok nem tartozékaik a terméknek.
 CZ -Náradí není součástí dodávky
 SK -Náradie nie je súčasťou dodávky
 PL -Narzędzia niedostarczone w zestawie.
 BG -Инструменти не са предоставени.
 RO -Scule neincluse
 GR -Τα εργαλεία δεν περιλαμβάνονται
 SI -Orodje ni priloženo.
 HRV -Alati se ne isporučuju
 TR -Ürüne dahil değildir
 UA -Інструменти не входять у комплект
 EST -Tööriistu ei ole kaasas.
 LT -Įrankių komplekte nėra
 LV -Rīki komplektā nav ietverti.

•AR الأدوات غير مرفقة مع المنتج.

A		x1	F		x1	Q		ABA1340	x1
B		x1	G		x1	R		ABA1338	x2
C		x1	H		x1	S			x1
D		x1	J		x1	T			x1
E		x3	K		x1	V			x1
			L		x1	W			x1
			M		x1			I15006	
			N		x1				
			P		x1				

TOOL ONLY
 SERT COMME OUTIL

BA		x1	∅ 8x200 mm	AAK0444
BB		x1	∅ 8x124mm	AAK0445
BC		x1	∅ 6x30 mm	9180147
BD		x4		AAK0368
BE		x1	∅ 6x14 mm	9160010
BF		x3	∅ 4,5x20 mm	AAK0401

1

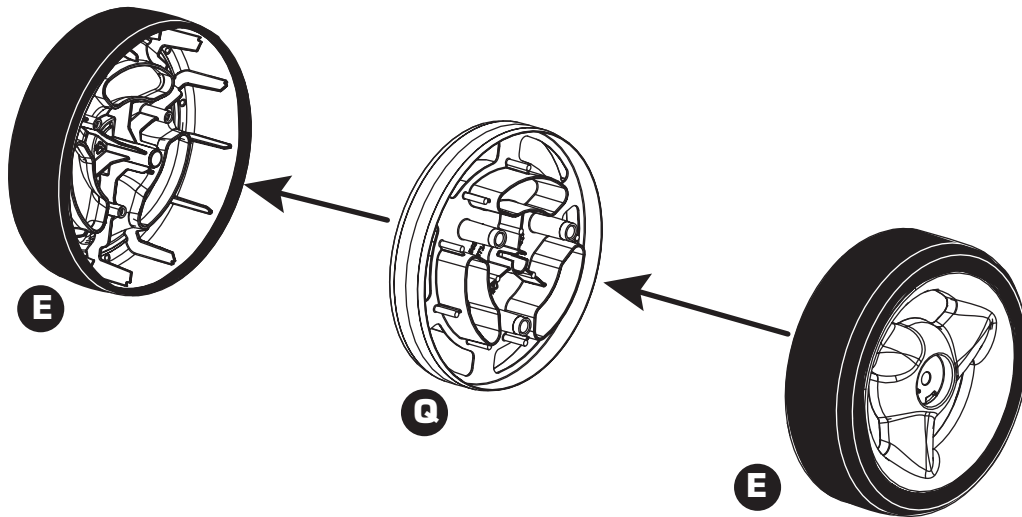

2

I

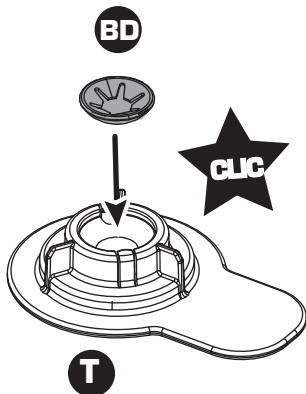

II

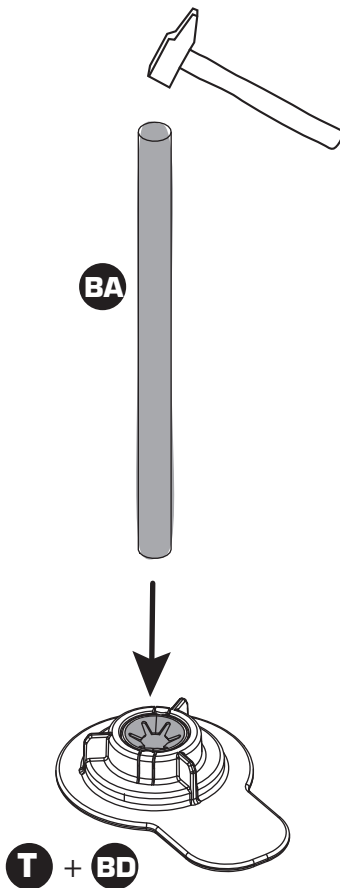

III

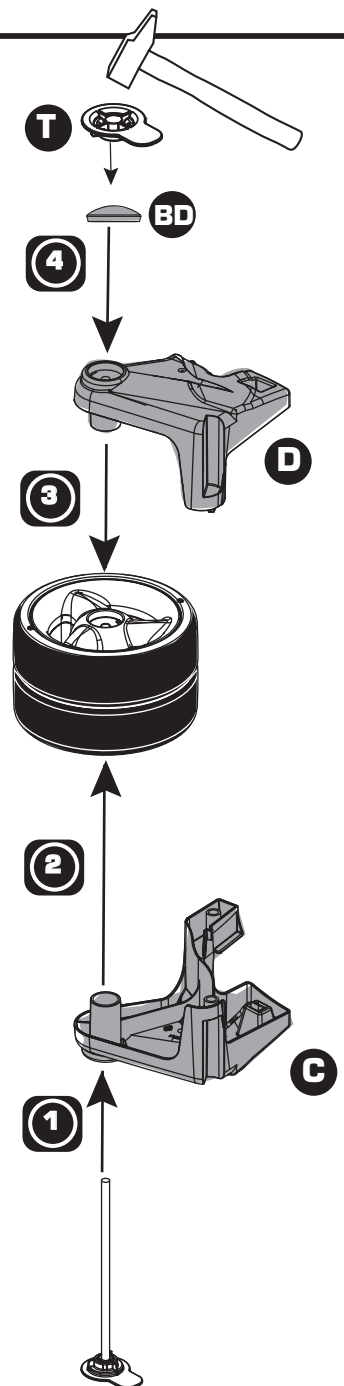

3

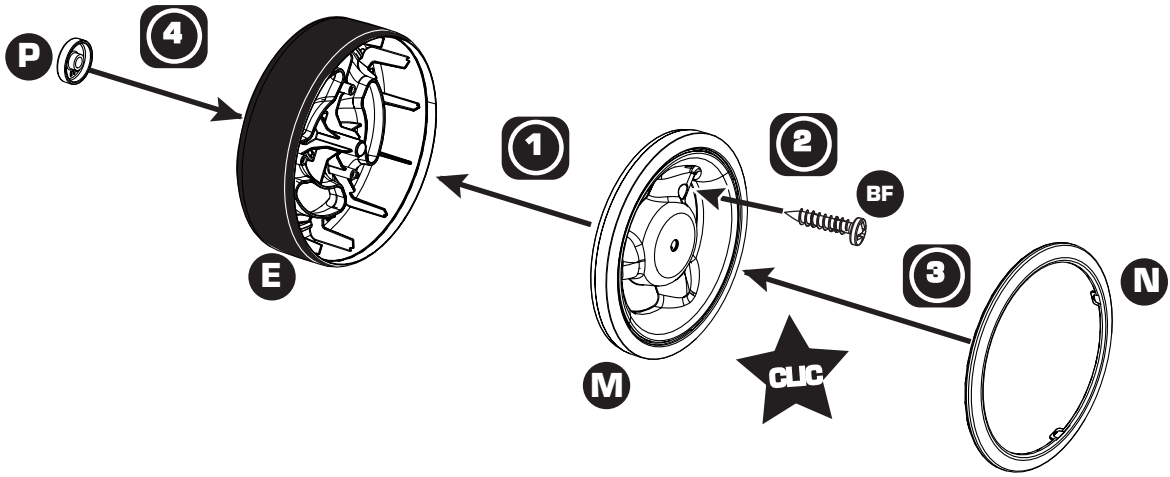

4

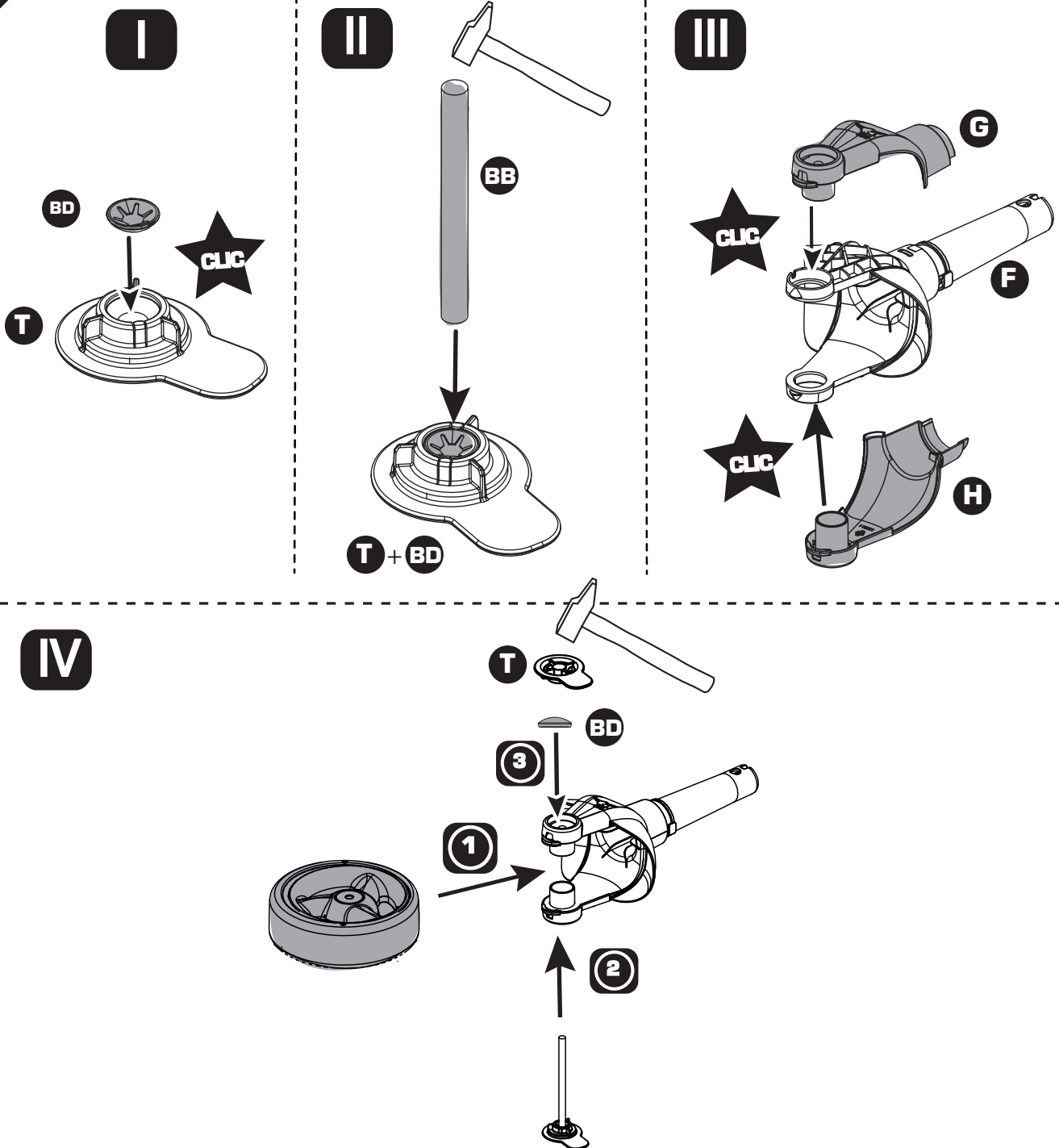

5

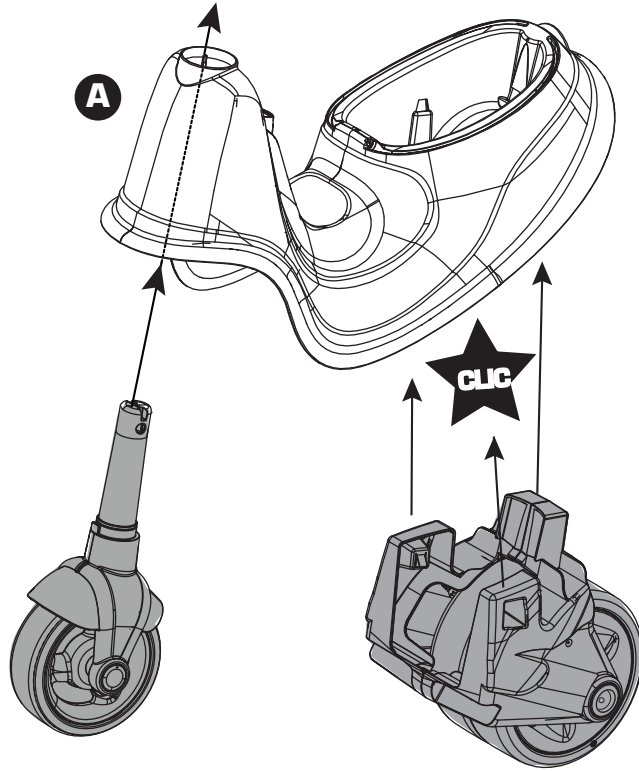

6

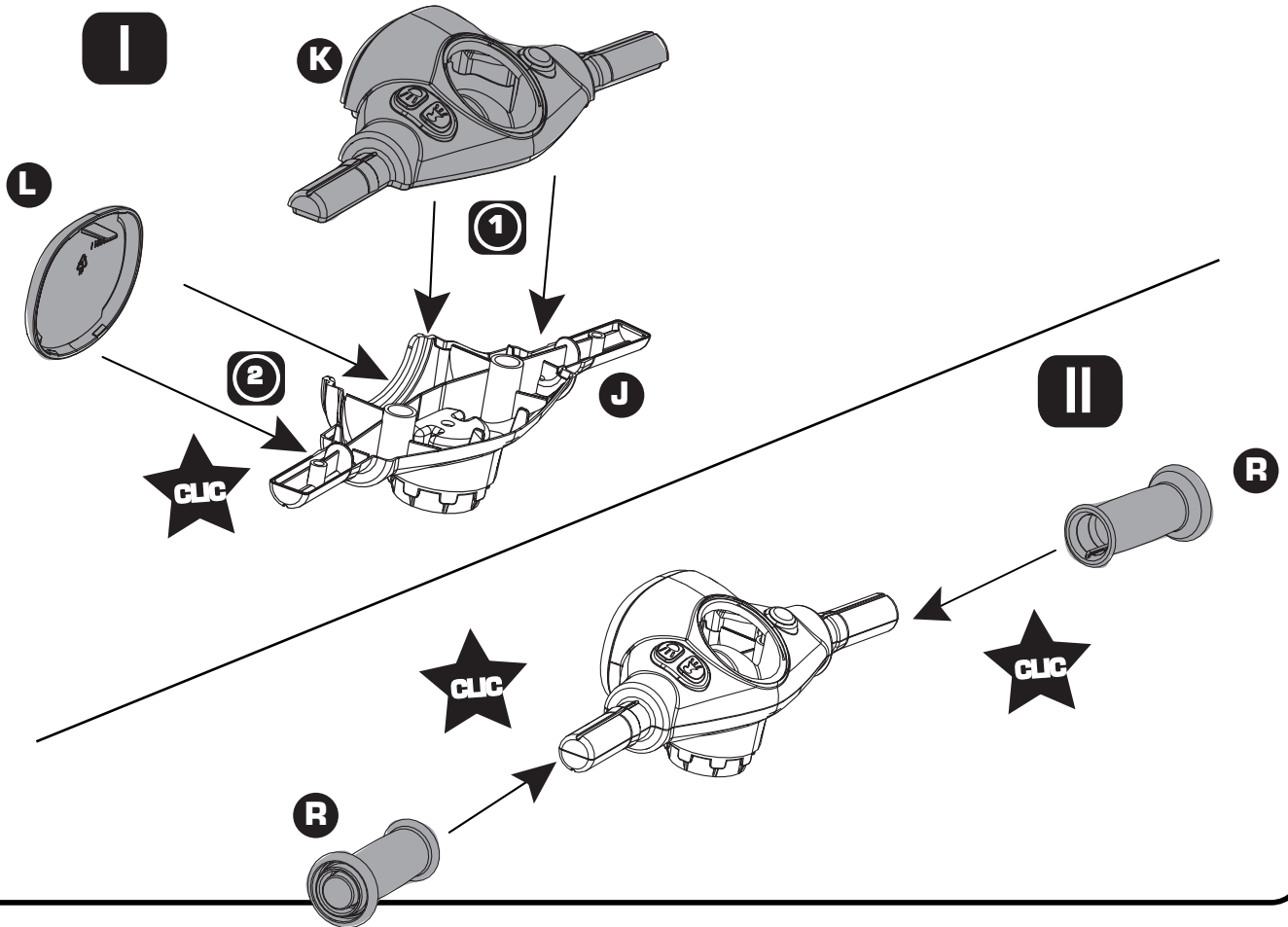

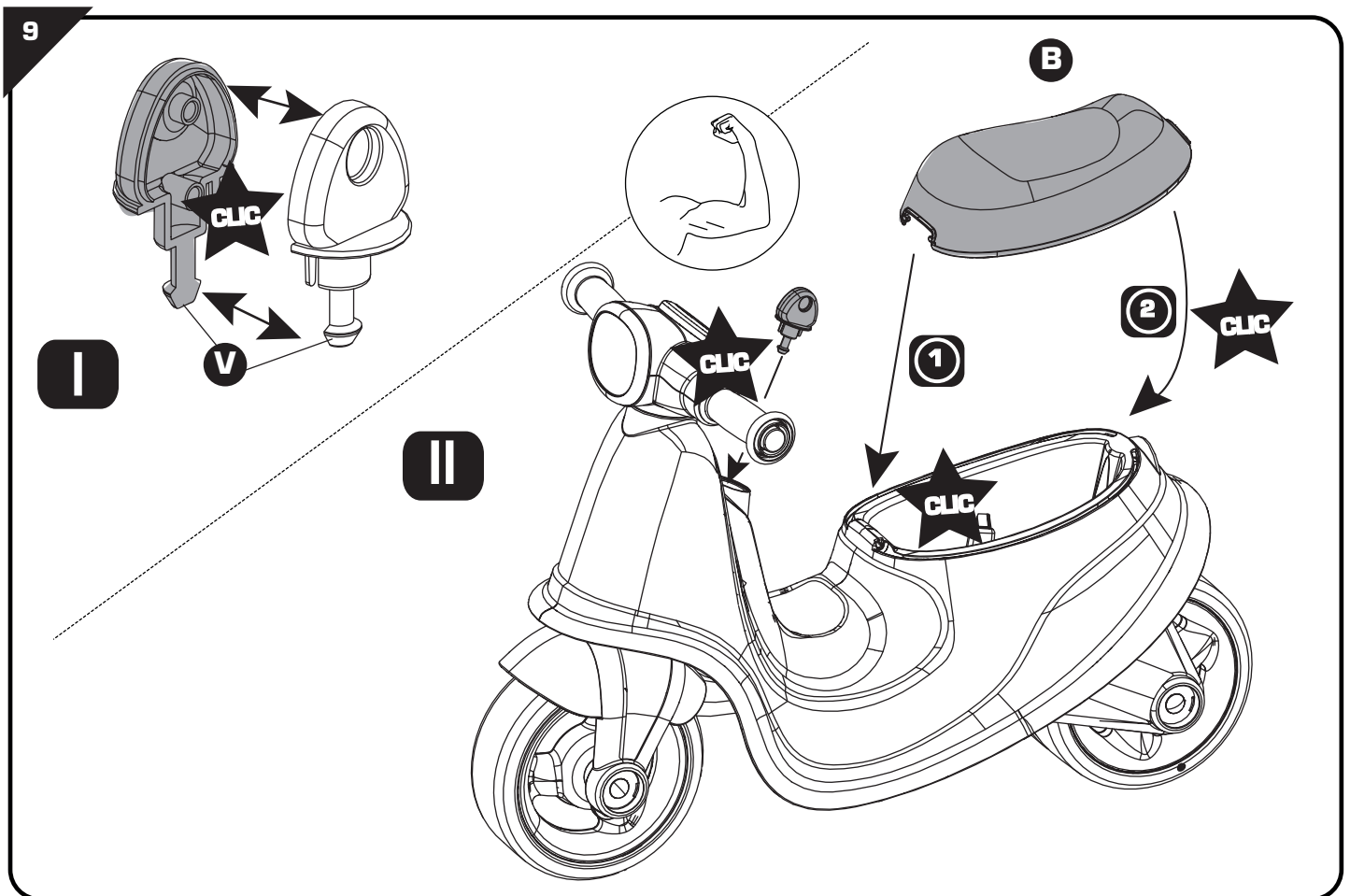
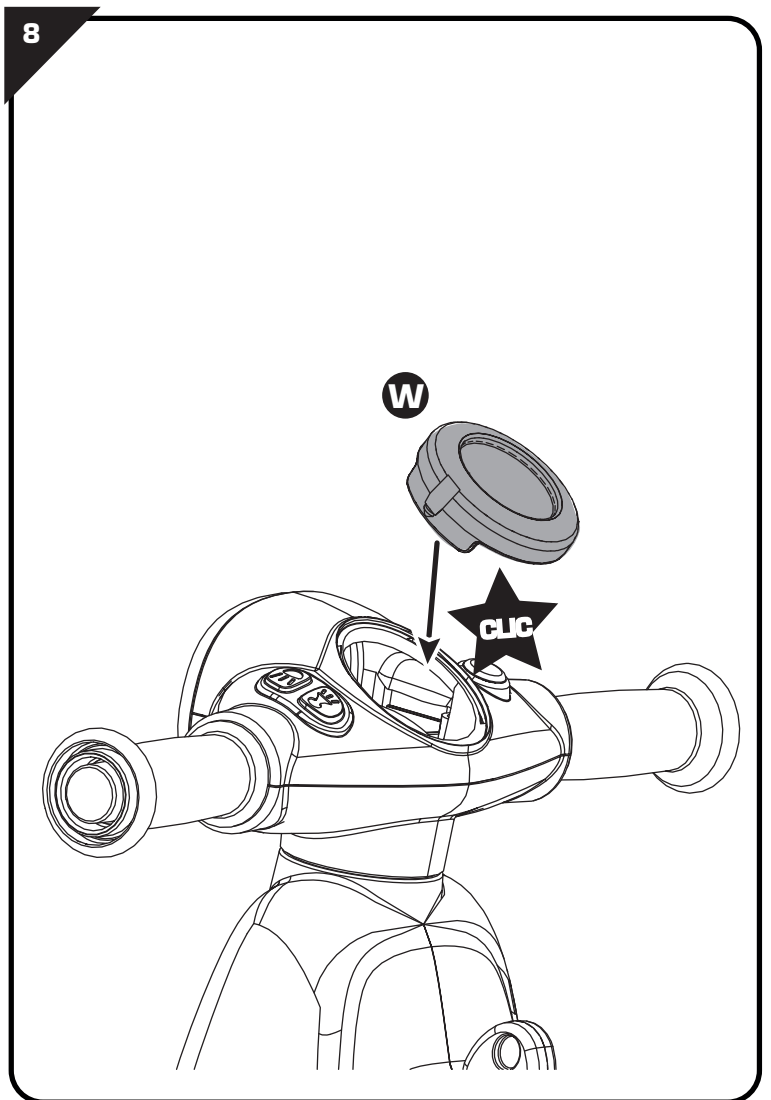
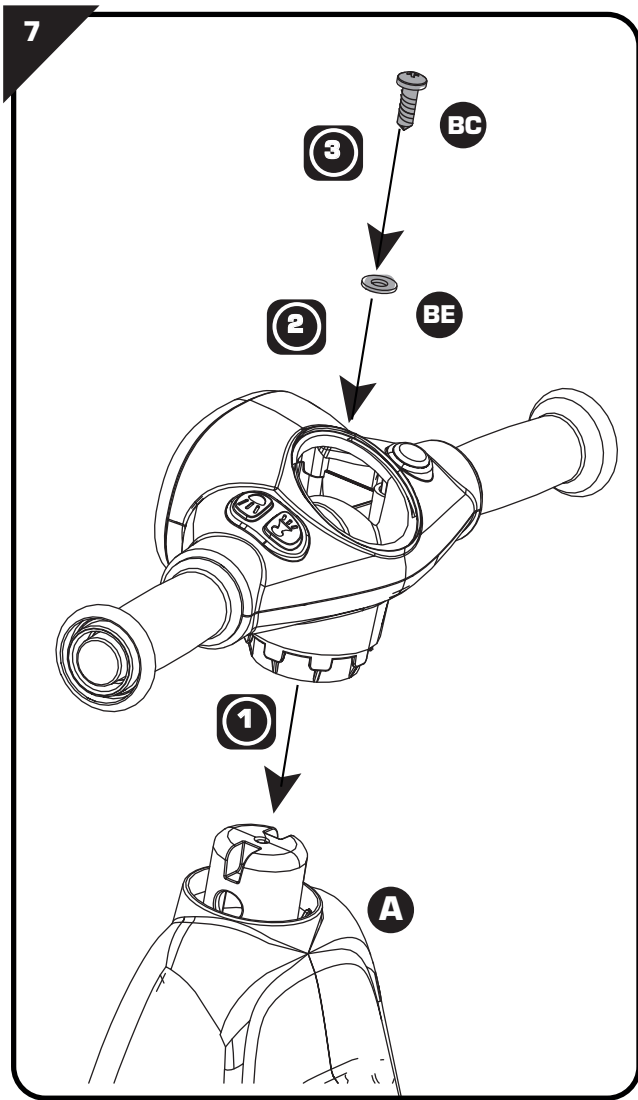

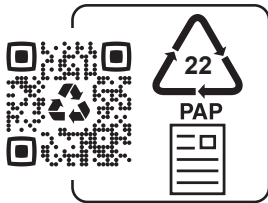
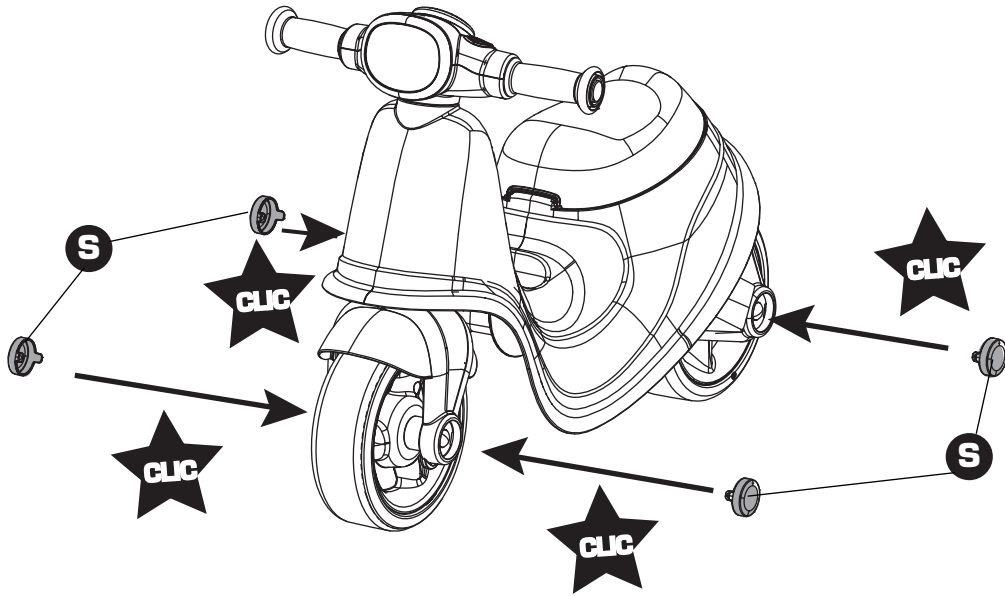

Adresses sur quefairedemesdechets.fr



(IT) RACCOLTA CARTA
VERIFICA LE DISPOSIZIONI DEL TUO COMUNE PER LA RACCOLTA DIFFERENZIATA



scooter

SMOBY TOYS S.A.S.

Service après vente / After sales service : www.smoby.fr
95 route du Haut Jura - 39170 Lavans-lès-Saint-Claude / France.

Smoby

Assistance consommateurs à nous retourner en cas de problèmes / Consumer assistance: for any problems, return this card /

Verbraucher-Info: Für weitere Auskünfte, senden Sie diese Karte bitte an / Klantenservice: voor inlichtingen, deze kaart naar ons terugsturen /

Atención al consumidor: para cualquier información, enviar esta tarjeta. / Assistenza per il consumatore: per informazioni, rispedire la presente cartolina.

NOM / NAME : _____

PRENOM / SURNAME : _____

RUE / STREET : _____

VILLE / TOWN : _____

CODE POSTAL / POSTAL CODE : _____

PAYS / COUNTRY : _____

N°TEL : _____

EMAIL : _____

Description du motif de la réclamation / Cause for complaint / Grund der Beanstandung / Omschrijving van de reden van de klacht / Detalle el motivo de su reclamación / Descizione del motivo del reclamo :

Manquant / Missing / Fehlende Teile / Tekort / Faltante / Mancante.

Cassé / Broken / Gebrochen / Gebroken / Rotura / Rotto.

Commentaires / Comments / Bemerkung / Opmerkingen / Comentarios / Commenti.

Ref: _____

Couleurs/Colors: _____

N° Notice / IS Number :
76A3166022264_
AAP2264B

N°: N°: N°: N°: N°: N°: N°:
Qté: Qté: Qté: Qté: Qté: Qté: Qté:



