

ADVANCED KIT

AIRPLANES SERIES

JUNKERS F13

EARLY PROD.

48002



SCALE
1:48

GENERAL INSTRUCTION

- HIGHLY DETAILED PLASTIC MODEL KIT
- PHOTO-ETCHED PARTS INCLUDED
- CLEAR PLASTIC PARTS INCLUDED
- HATCHES CAN BE ASSEMBLED IN OPEN OR CLOSED POSITION
- ENGINE & INTERIOR COMPARTMENT ACCURATELY REPRESENTED IN THE MODEL
- DECAL SHEET FOR 3 VARIANTS

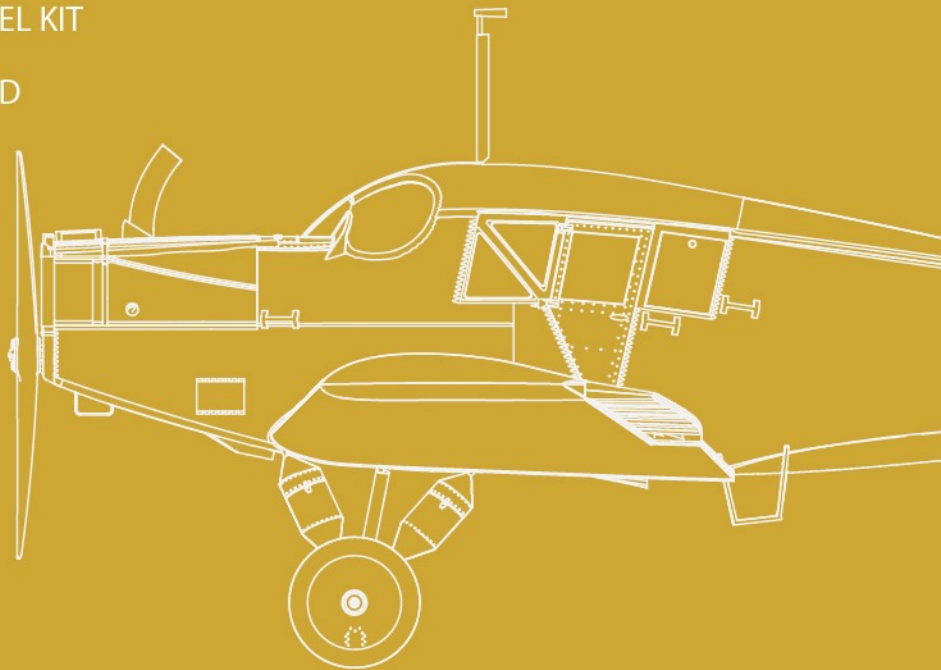

1 Dz-33/D-154 „Reiher“ Aero-Targ Poznanchartered from Danziger Luftpost GmbH, 1921



VOLODYMYR BOOTH 2024

UWAGA

Przy stosowaniu kleju i farb wszystkie prace należy wykonywać w przewietrzonym miejscu z dala od źródeł ognia. Oddziel części od wlewków nożem lub innym ciętciem narzędzie. Oczyść lampę błyskową i wytnij punkty pilnikiem igłowym i papier ścierny. Złóż modele zgodnie z schemat montażu. Dla ułatwienia montażu każda część jest oznaczona numerem. Po złożeniu zestawu mogą pozostać niewykorzystane części.

УВАГА

При використанні клею та фарб всі роботи проводити подалі від джерел вогню у приміщенні, що добре провітрюється. Деталі відкремлювати від літників ножем або іншим ріжучим інструментом. Зачисти облой і місця зрізу за допомогою надфайлу та наждачного паперу. Будування моделі виконувати згідно зі схемою. Для зручності побудови кожна деталь позначена номером. Після складання можуть залишитися невикористані деталі.

CAUTION

When you use glue or paint, do not use near open flame, and use in well ventilated room. When you take parts off from the runner frame, use modeling scissors or cutter. See the bottom of this column for the meaning of symbols. Extra details can remain after assembling of the kit.



POWTÓRZ DWA RAZY
MAKE 2PCS
2 TEILE FERTIGEN
EFFECTUER 2 PIECES
FARE DUE PEZZI
TEE 2 KPL
GÖR 2 ST
КІЛЬКІСТЬ РАЗІВ



NIE UŻYWAJ KLEJU
DO NOT CEMENT
NICHT KLEBEN
NE PAS COLLER
NON INCOLLARE
EILIMÄÄ
LIMMAEJ
НЕ КЛЕІТИ



OPCJE
OPTIONAL
NACH BELIEBEN
FACULTATIF
FACOLTATIVO
VALINNANVARAINEN
VALBAR
ВАРИАНТИ



ZROBIĆ DZIURĘ
OPEN HOLE
OFFNEN
FAIRE UN TROU
FORO APERTO
AVAAREIKÄ
ÖPPNÄ HALET
ЗРОБИТИ ОТВІВ



ODCIĄĆ
REMOVE
ENTFERNEN
RETIRER
SEPARARE
POISTA
AVLÄGNSNA
ВІДПІЗАТИ



ZGINĄĆ
BEND
BITTE BIEGEN
PLIER S'IL VOUS PLAÎT
PIEGARE
TAITA
BÖKA
ВИГНУТИ

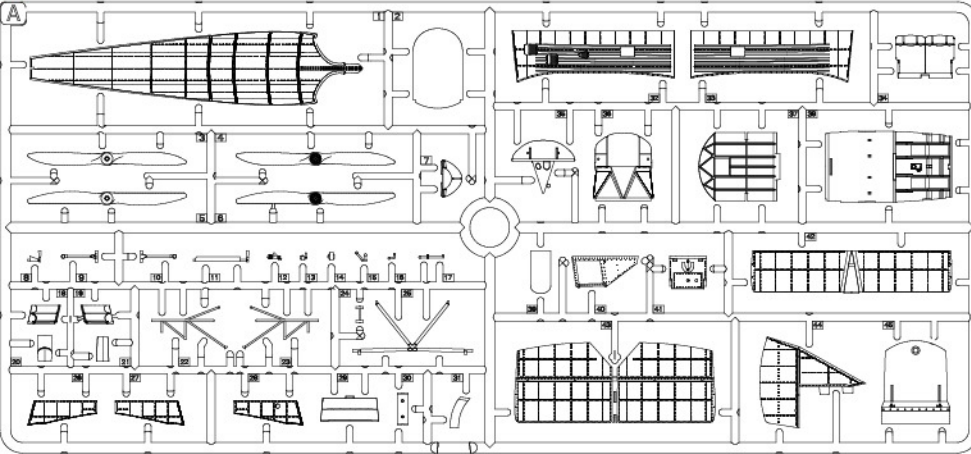
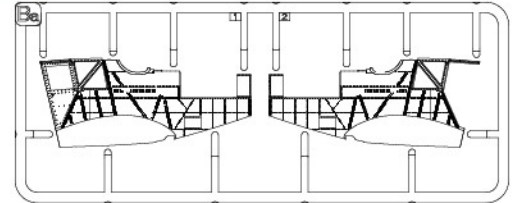
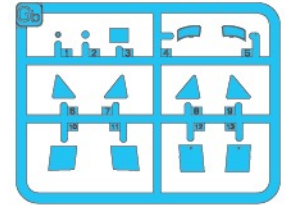
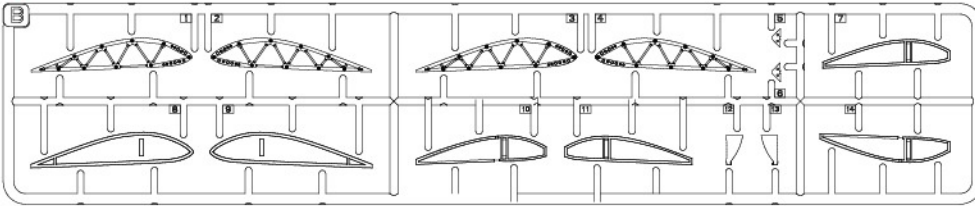
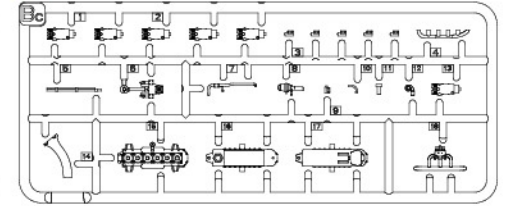
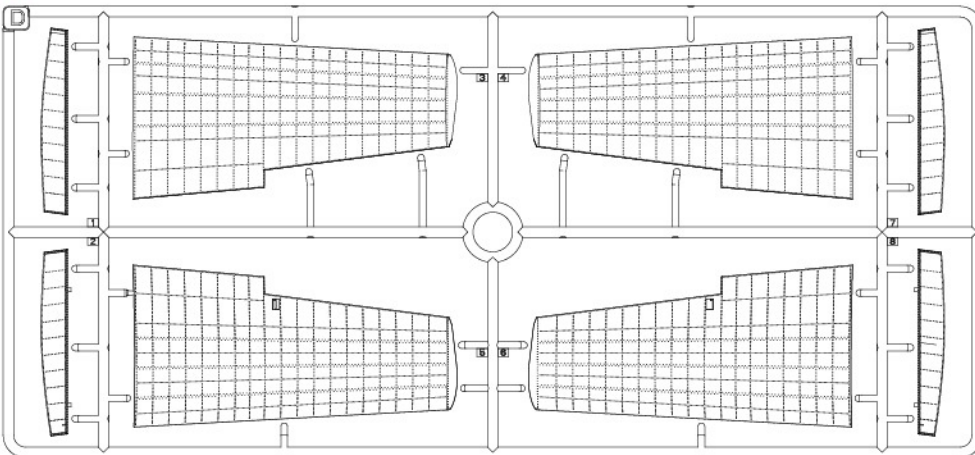
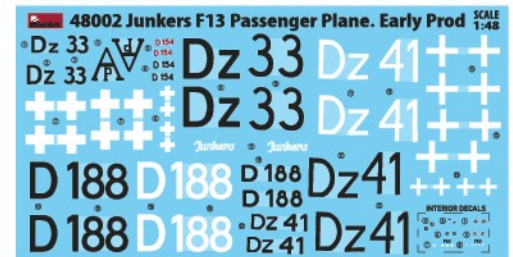
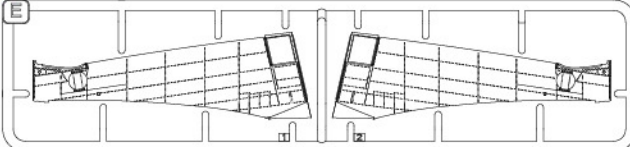
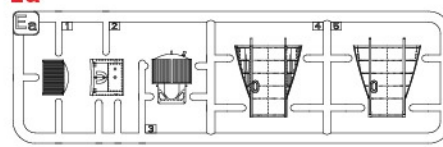
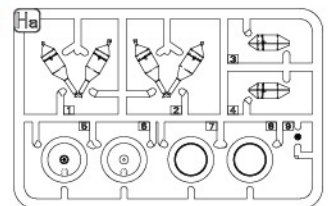
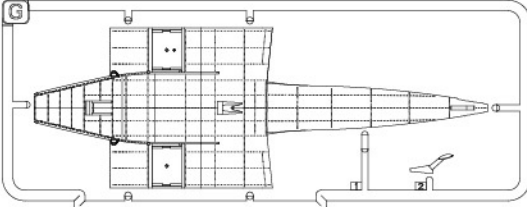
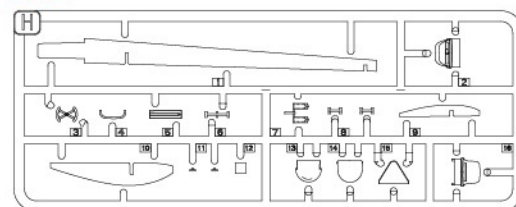
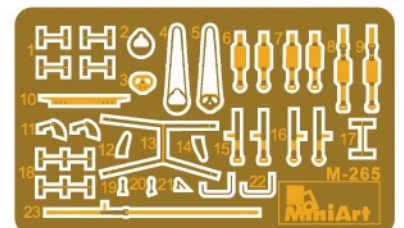

ZRÓB TO SAM
SCRATCHBUILD
AM MEISTEN ZU MACHEN
FAIRE LE PLUS
RENDITI
TEE ITSE
GÖR DIG SJÄLV
ЗРОБИТИ САМОМУ

PARTS**A****Ba****Gb****Clear Parts****B****Bc****D****Decal Sheet****E****Ea****Ha x2****G****H x2****M-265**

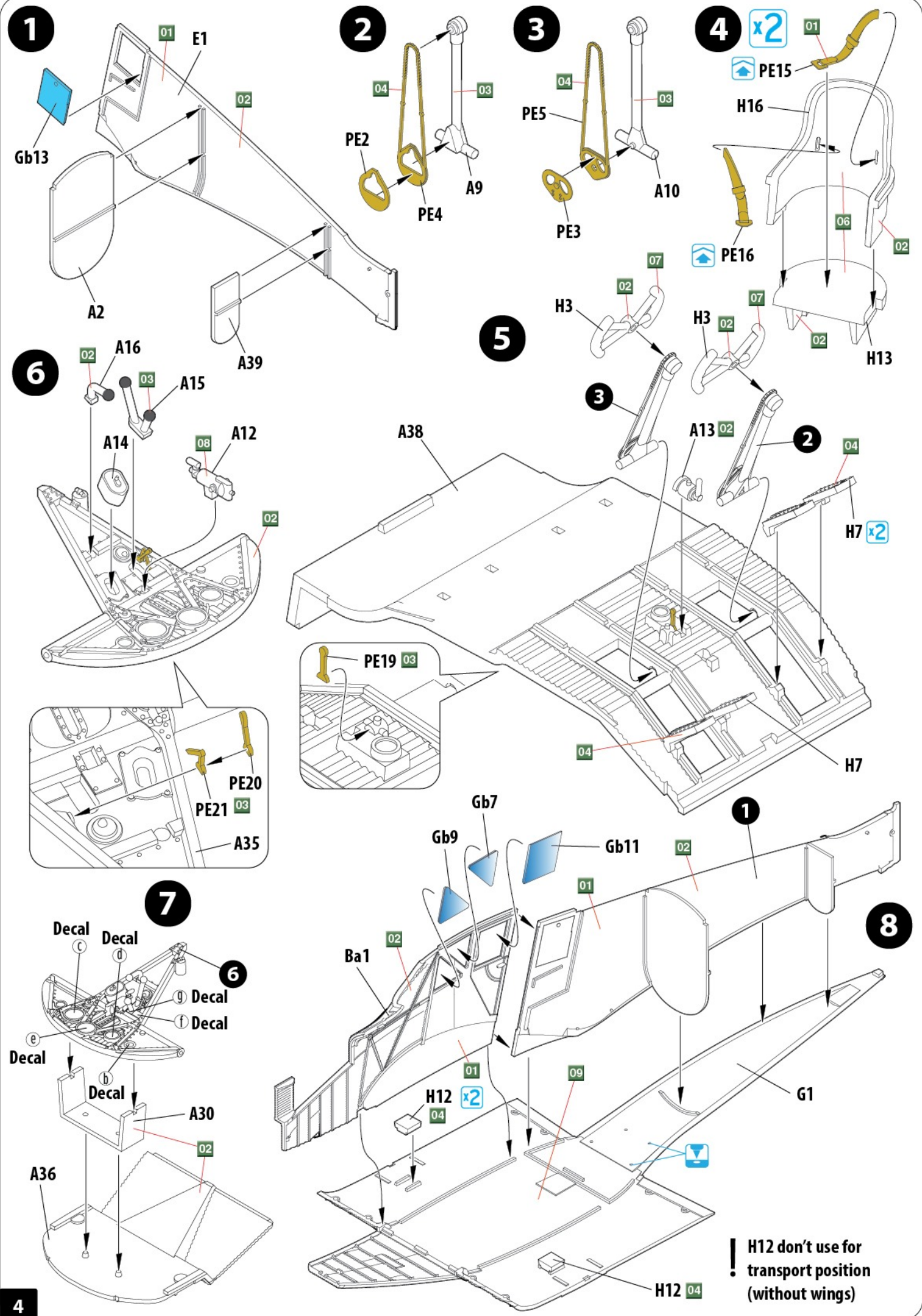

1

2

3

4

5

7

8

4

! H12 don't use for transport position (without wings)

x2

x2

x2

x2

x2

01

E1

Gb13

A2

A39

6

02

A16

03

A15

A14

08

A12

02

A38

3

07

PE16

H3

02

07

H13

02

06

H16

01

PE15

04

PE2

PE4

A9

03

PE5

PE3

A10

03

5

3

02

H3

02

H3

02

A13

2

H7

x2

04



PE19

03

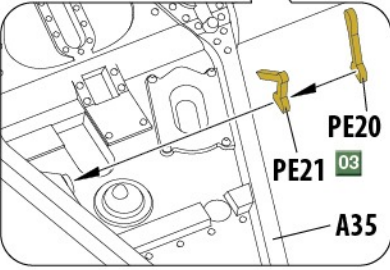

PE20

PE21

03

A35

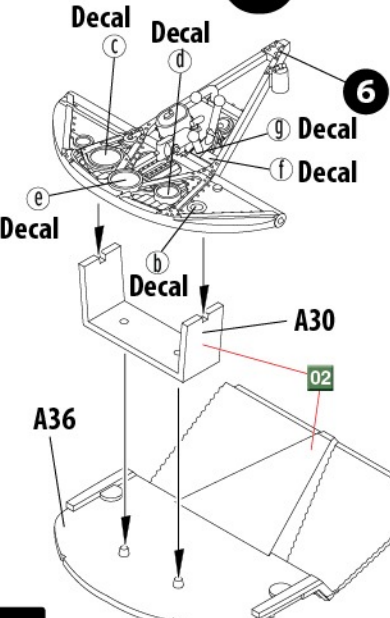

Decal

Decal

6

Decal

Decal

Decal

Decal

b

A30

02

A36

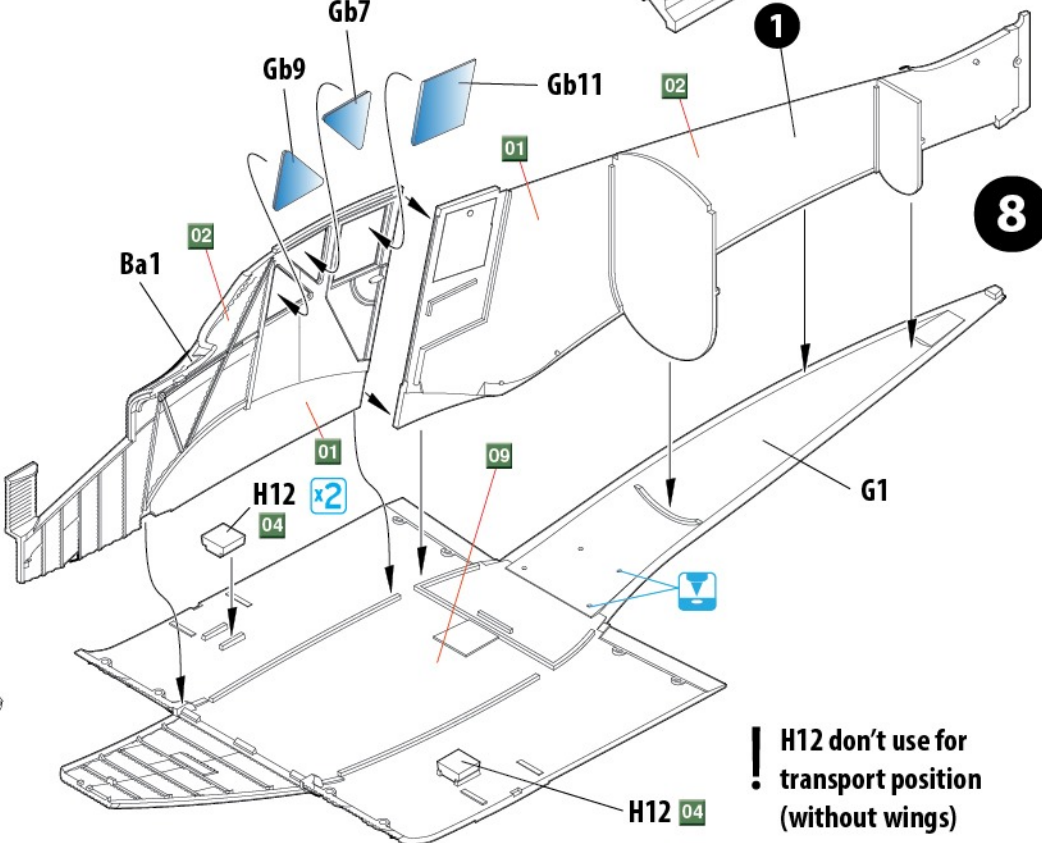

Ba1

02

01

H12

04

x2

01

H12

04

x2

09

G1

H12

04

x2

!

H12 don't use for transport position (without wings)

9

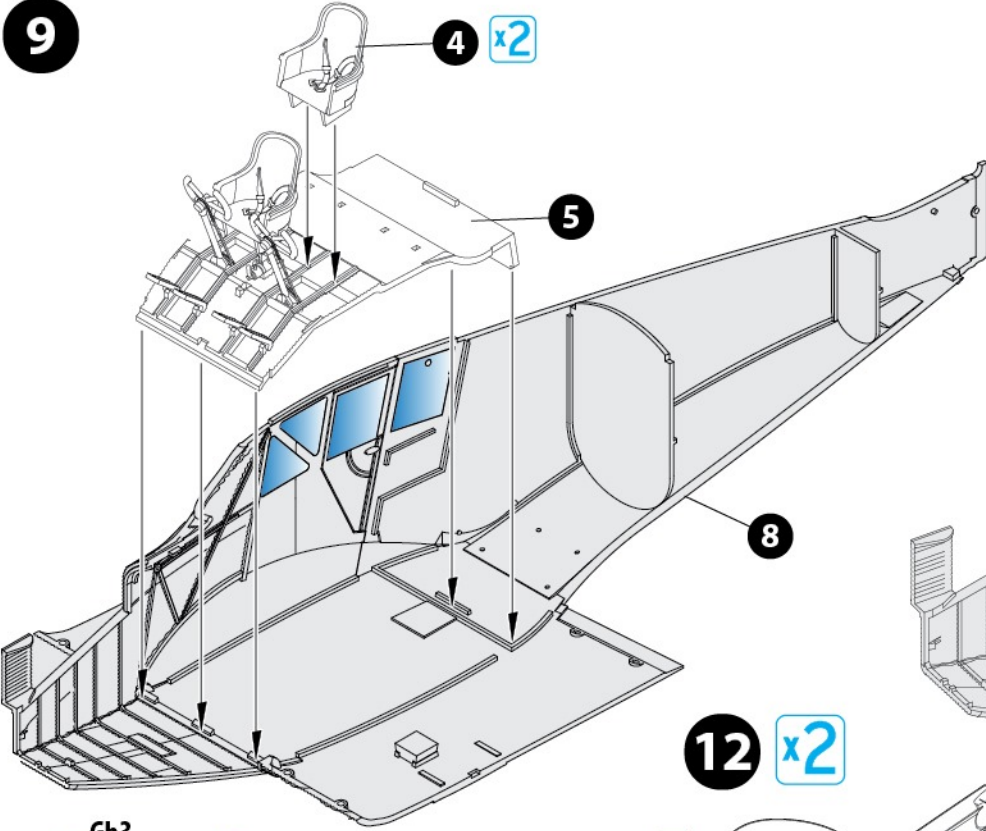

10

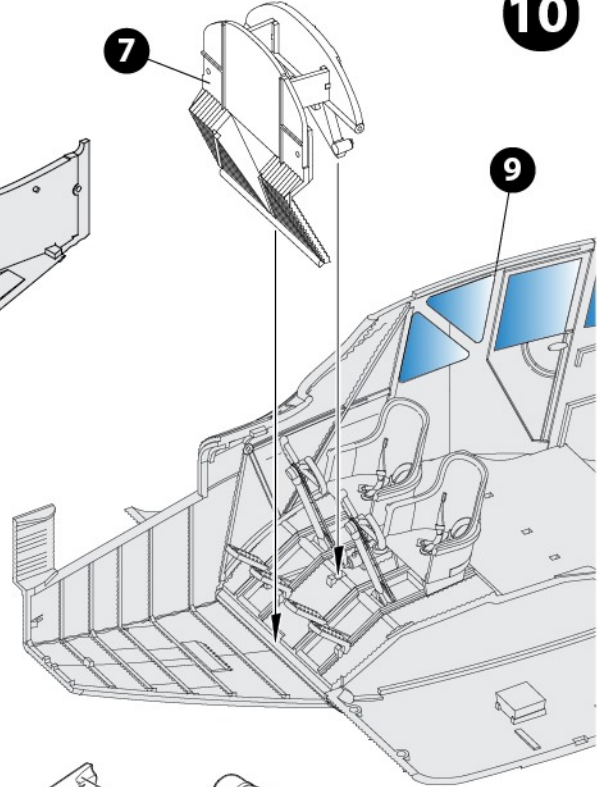

12 x2

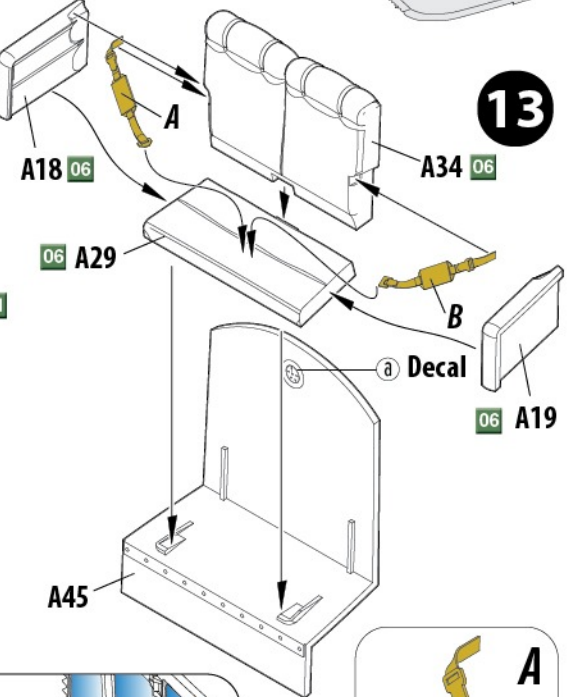
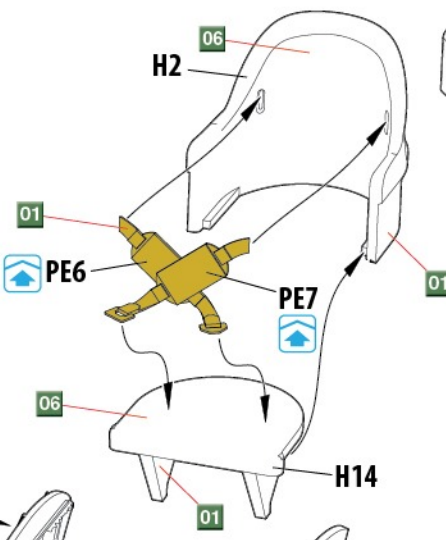
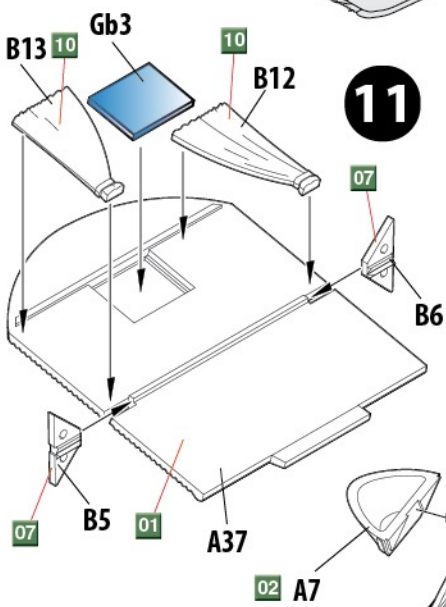

14

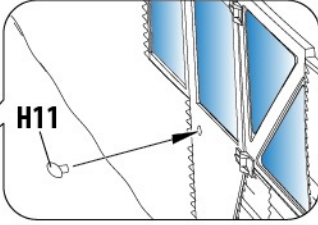
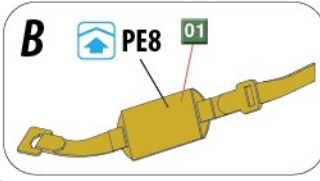
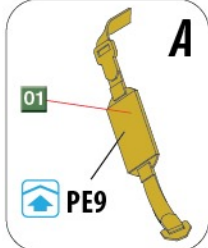
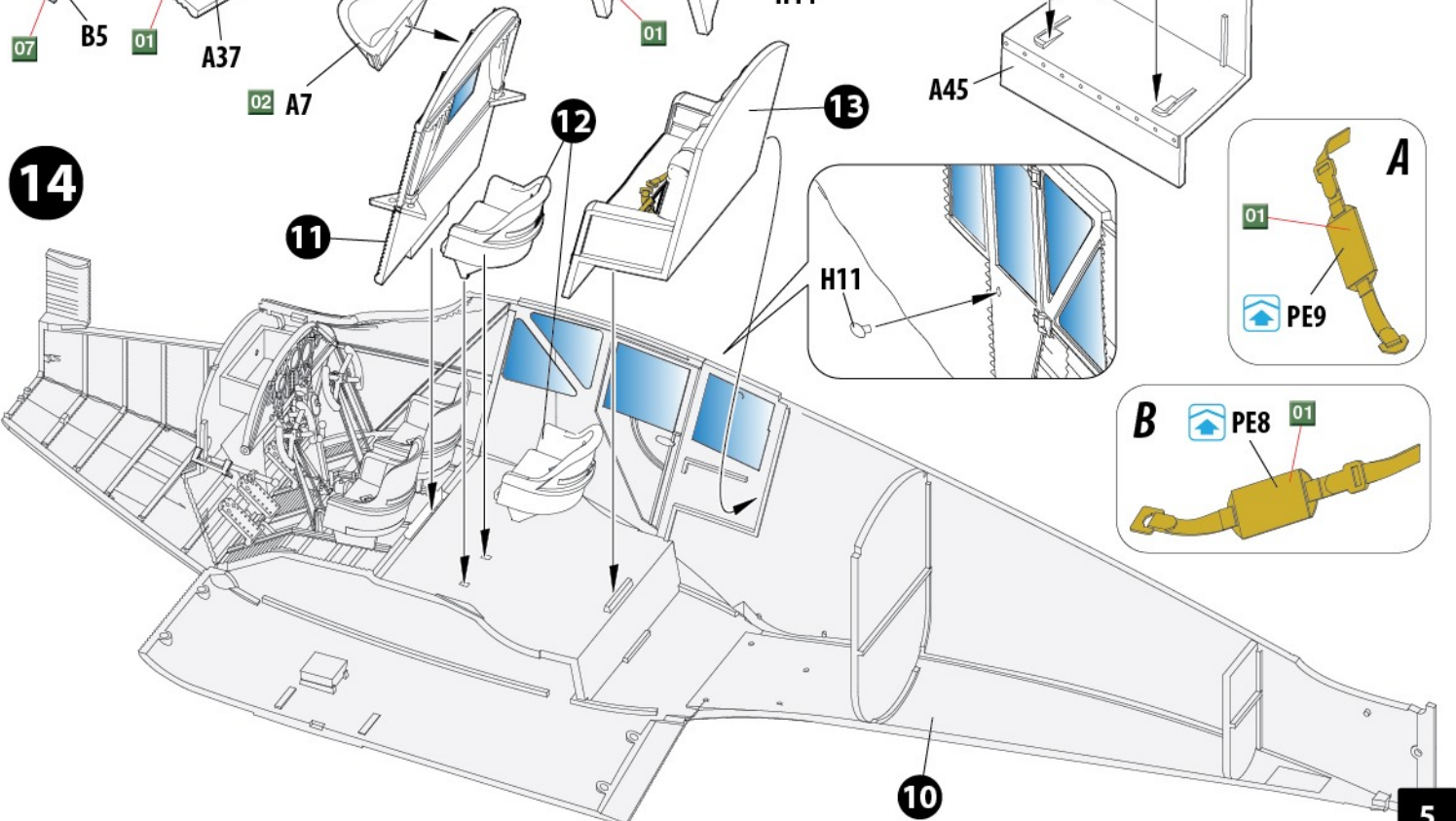

5

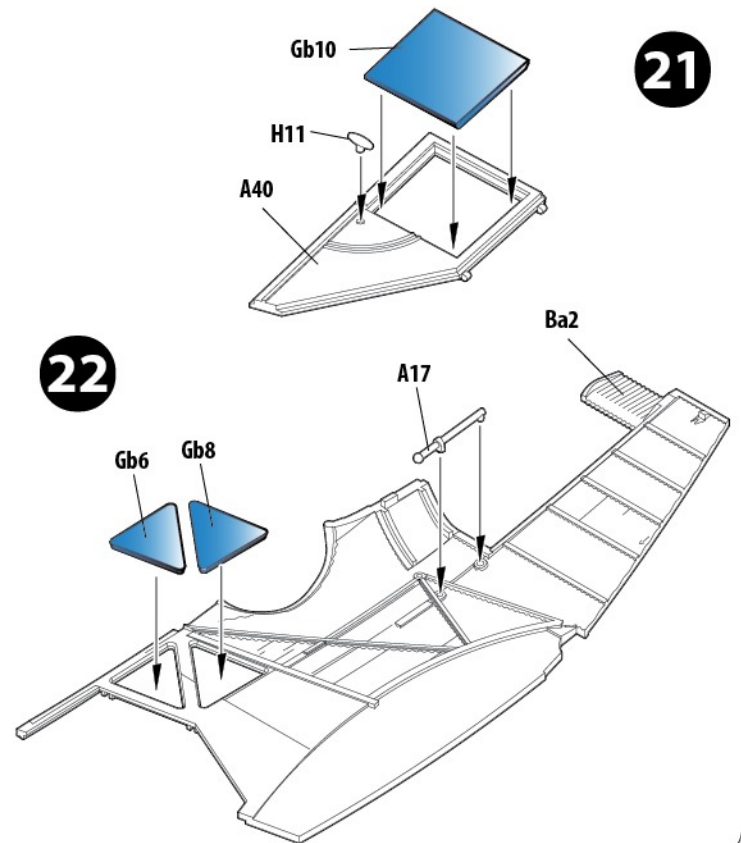
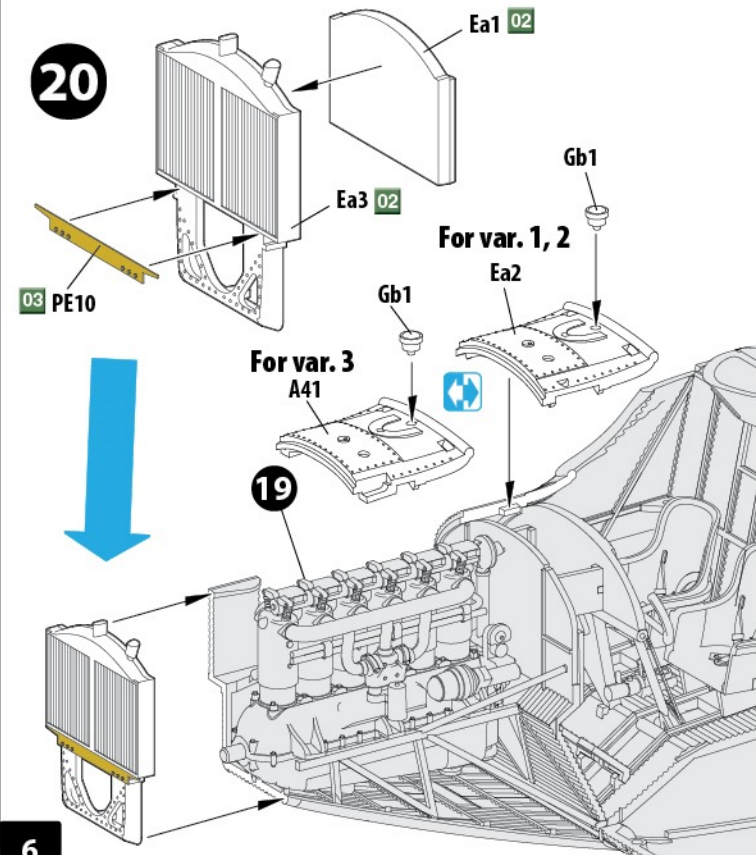
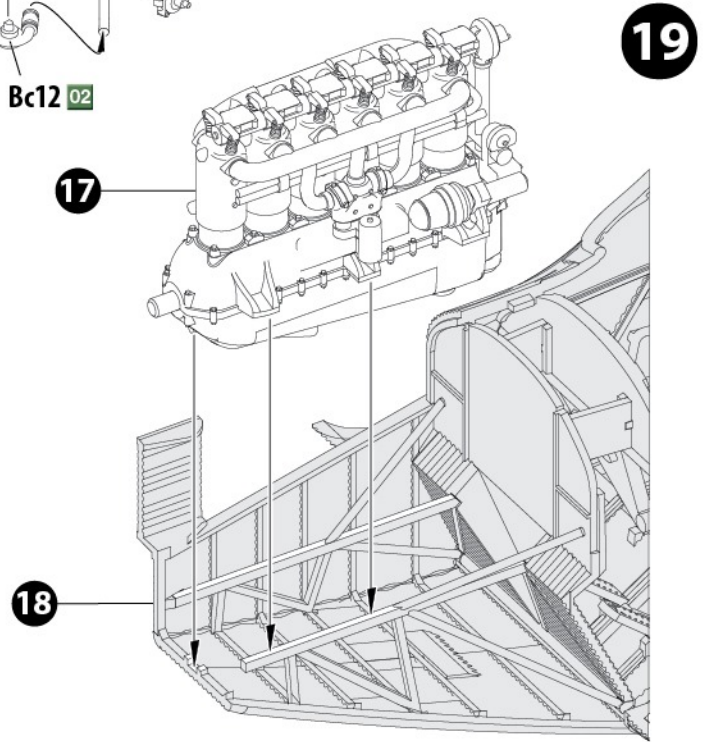
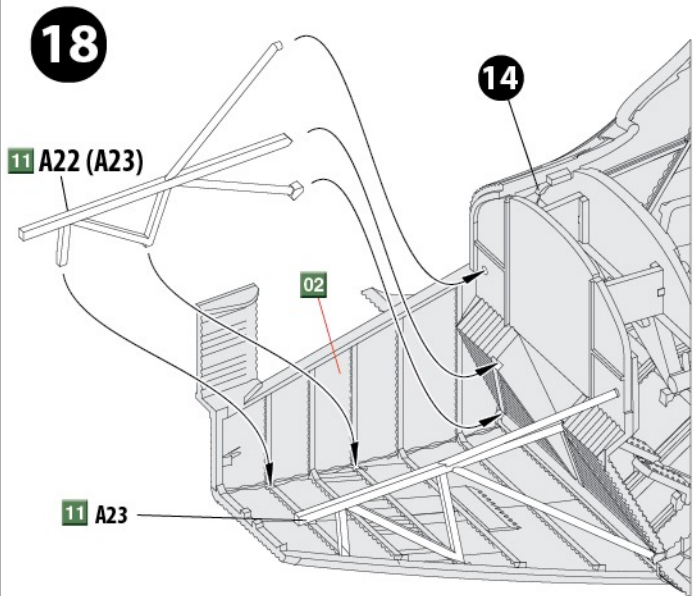
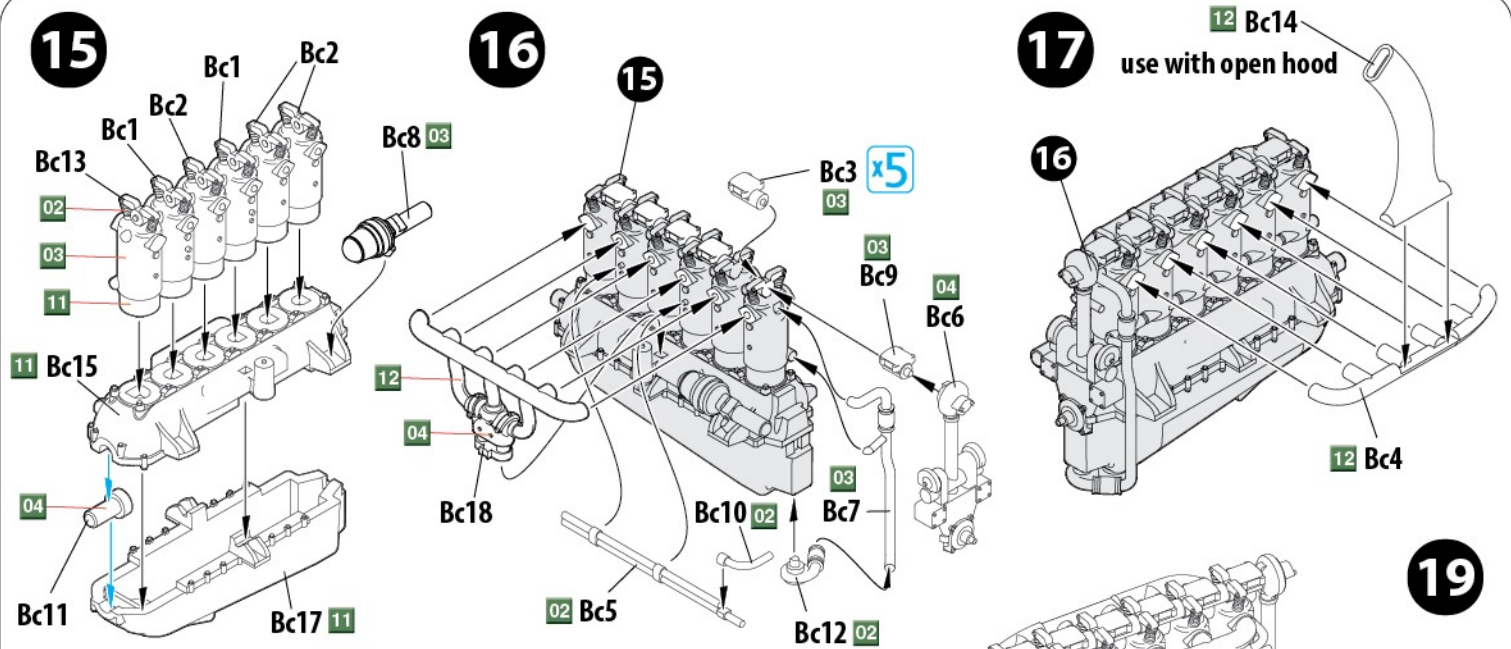

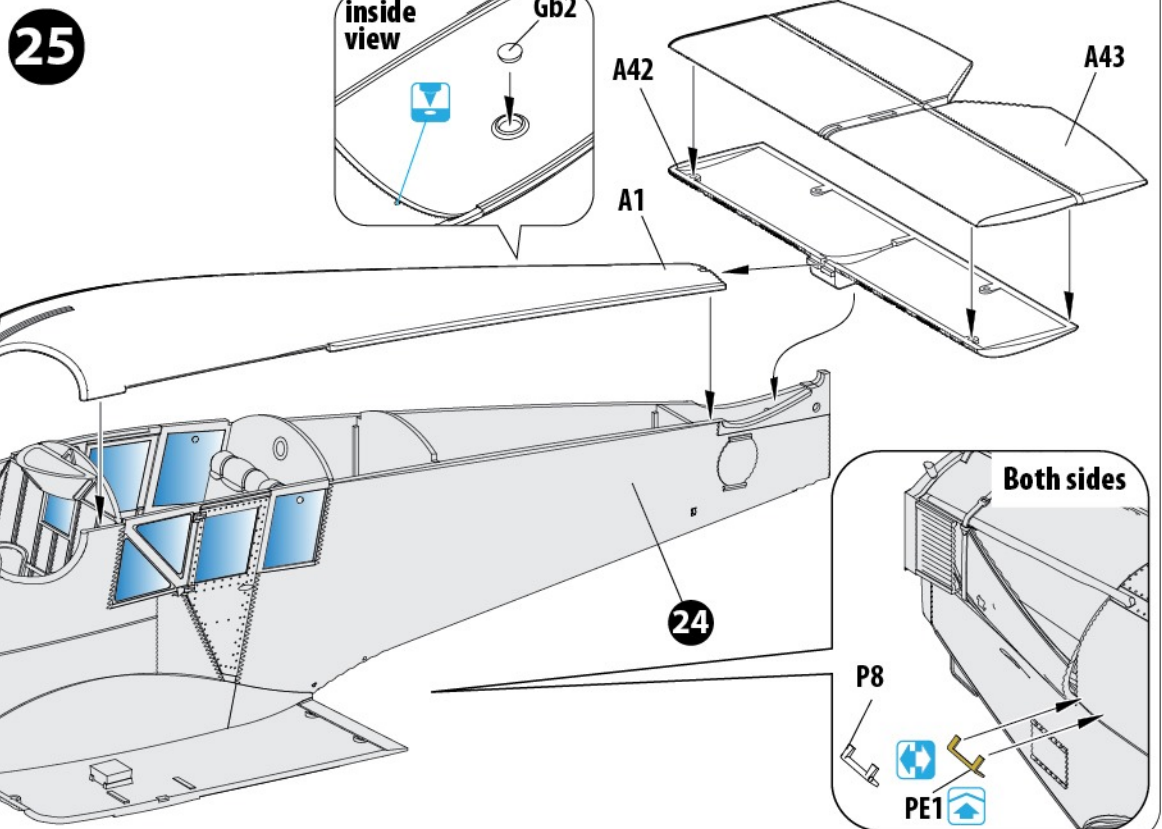
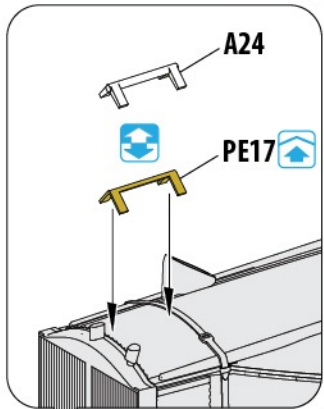
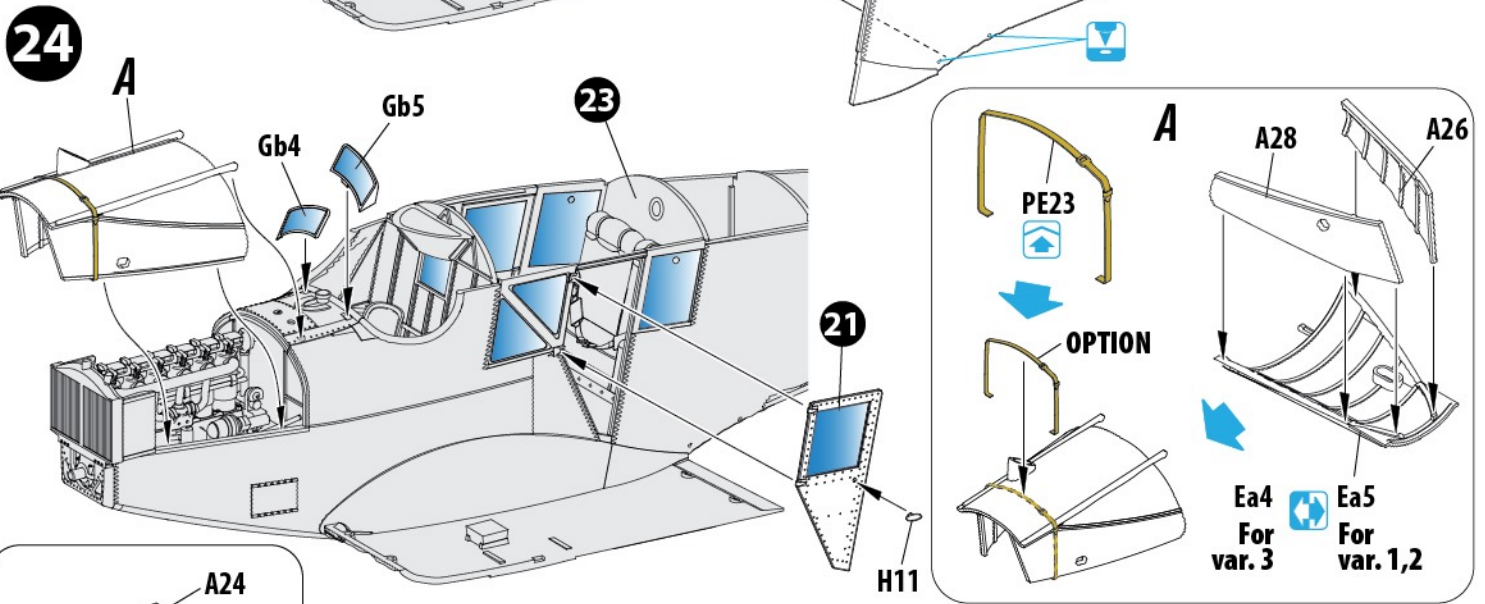
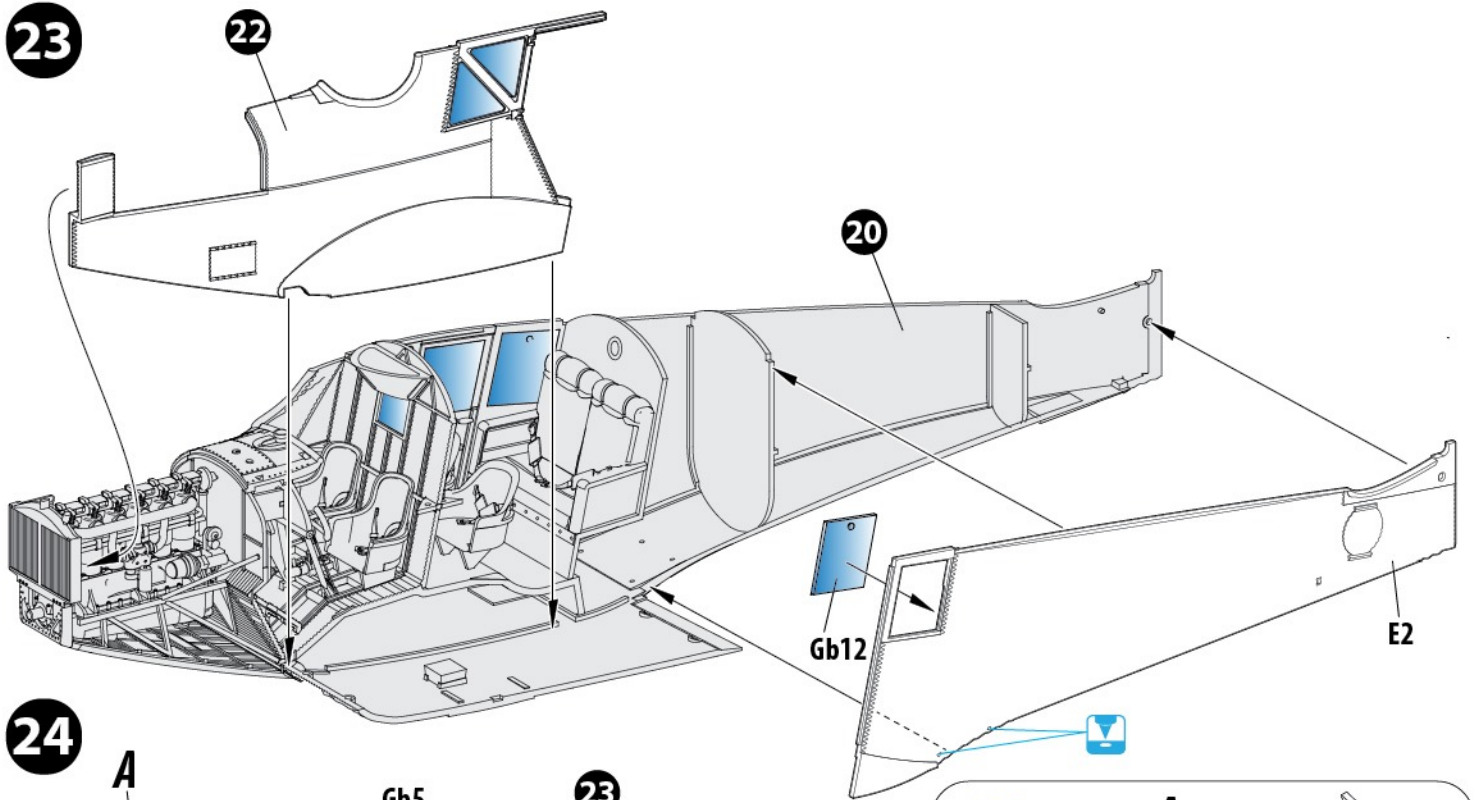

26

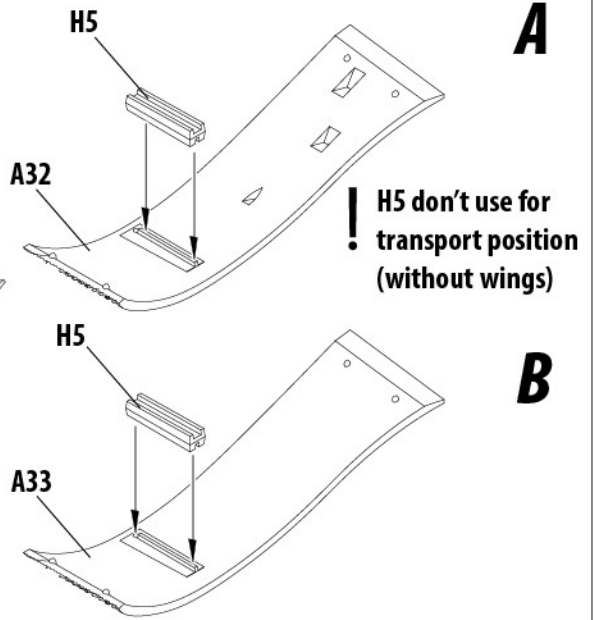
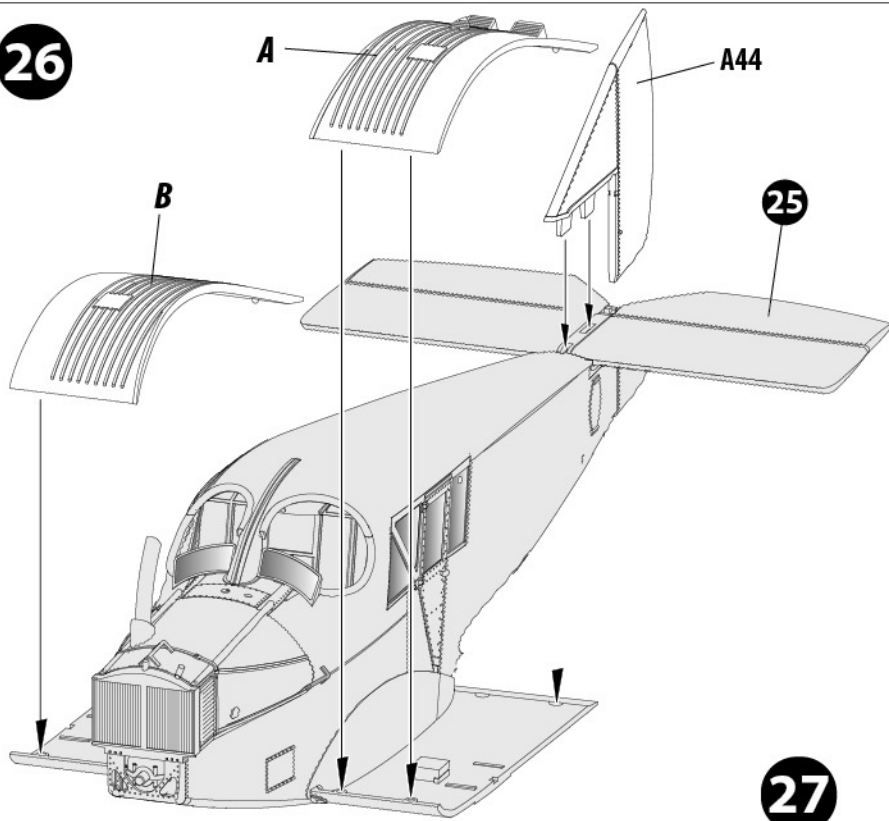

27

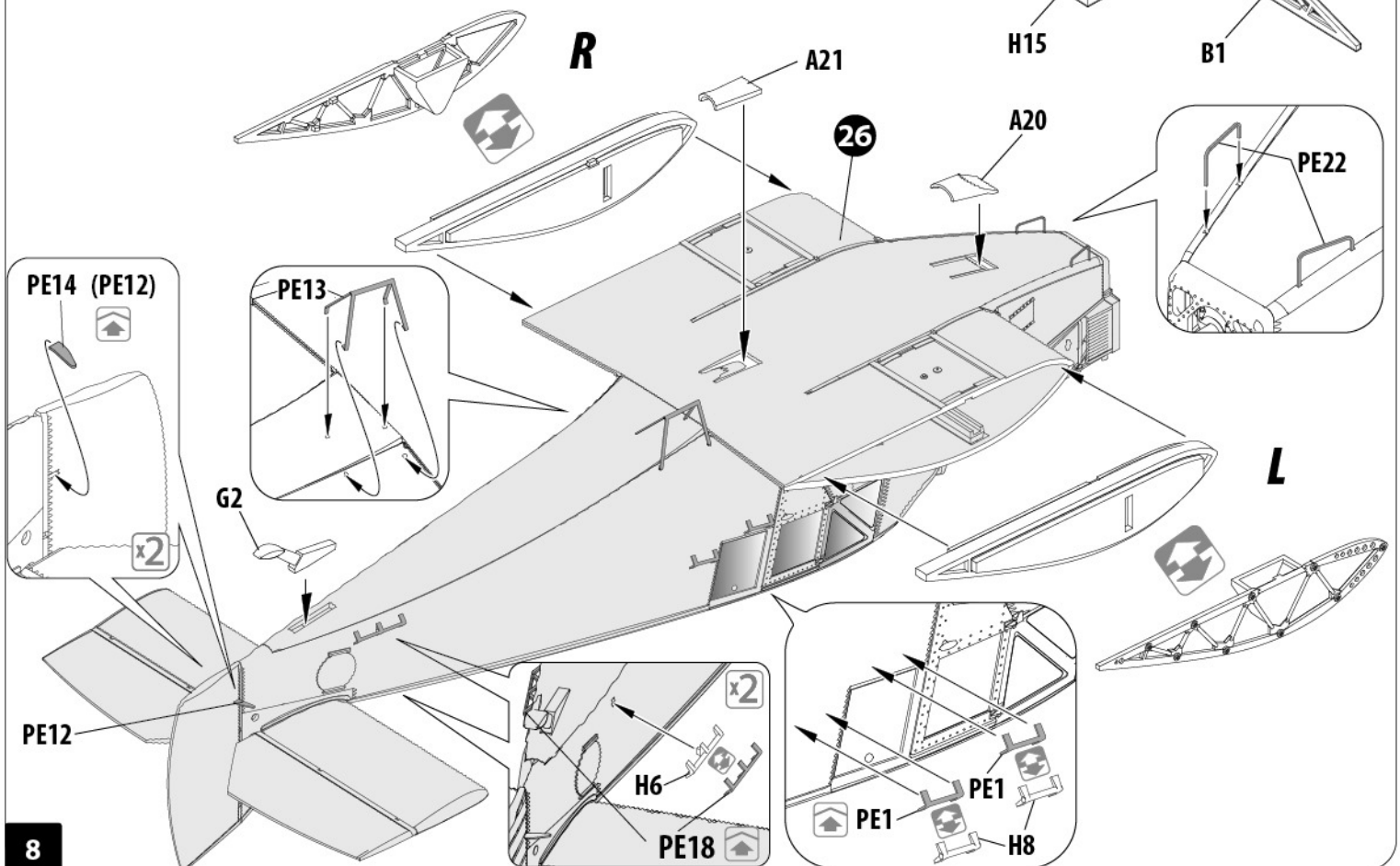
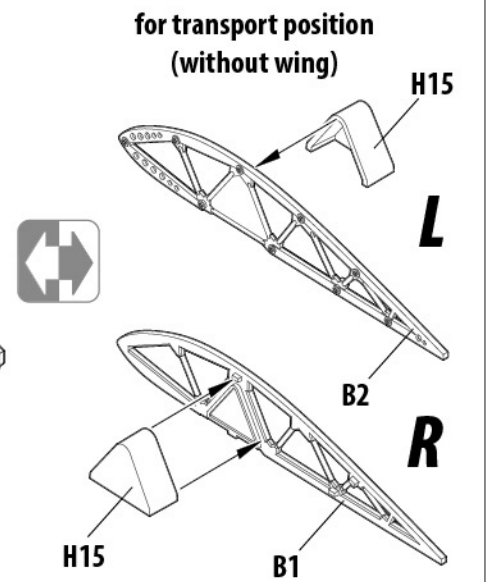
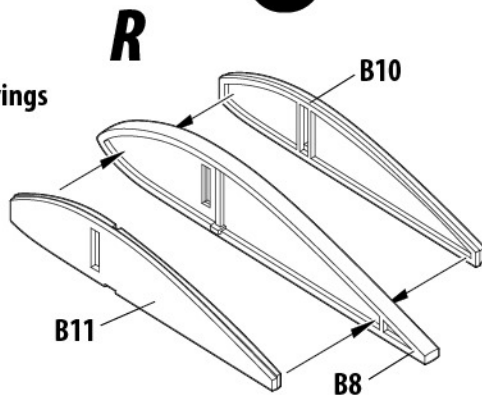
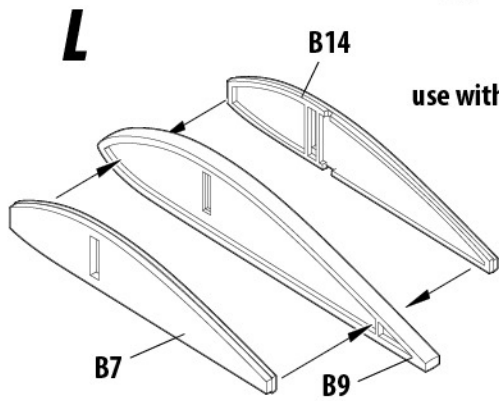

cut for transport position
(without wings)

H1

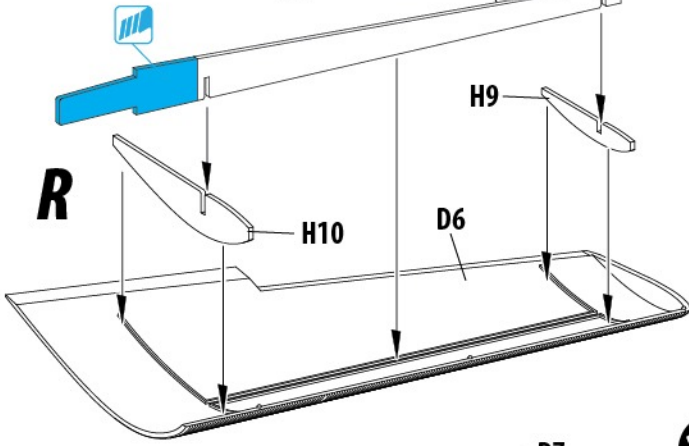

R

H10

D6

28

cut for transport position
(without wings)

H1

H9

D5

H10

L

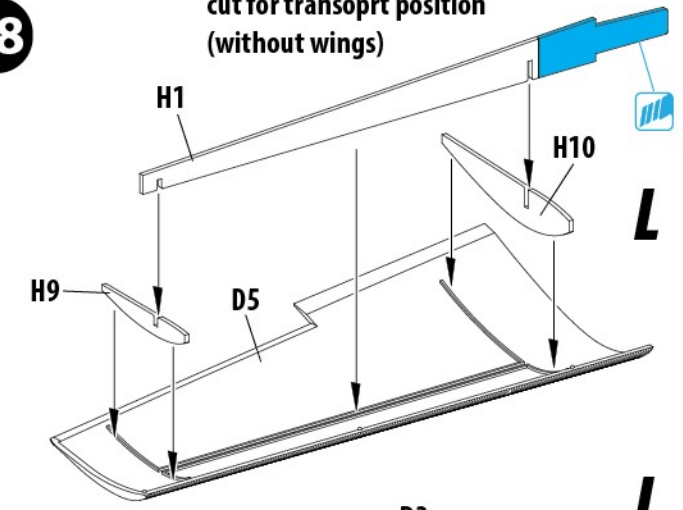

29

R

D7

D8

D4

28 R

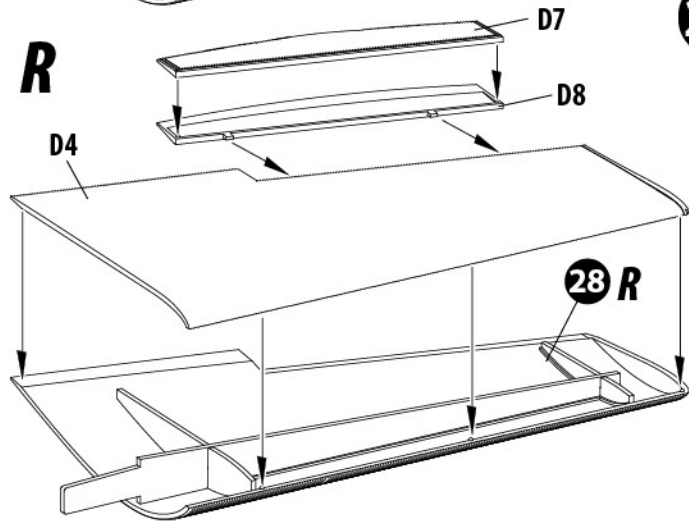

L

D1

D3

D2

28 L

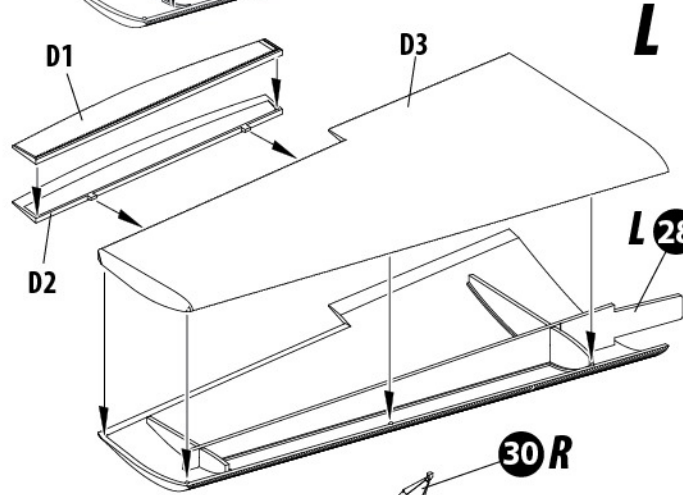

30

R

Ha3

Ha3

Ha1

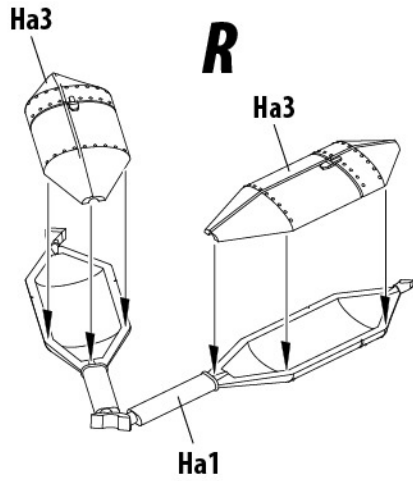

31

Ha5

30 L

Ha6

Ha6

Ha5

A25

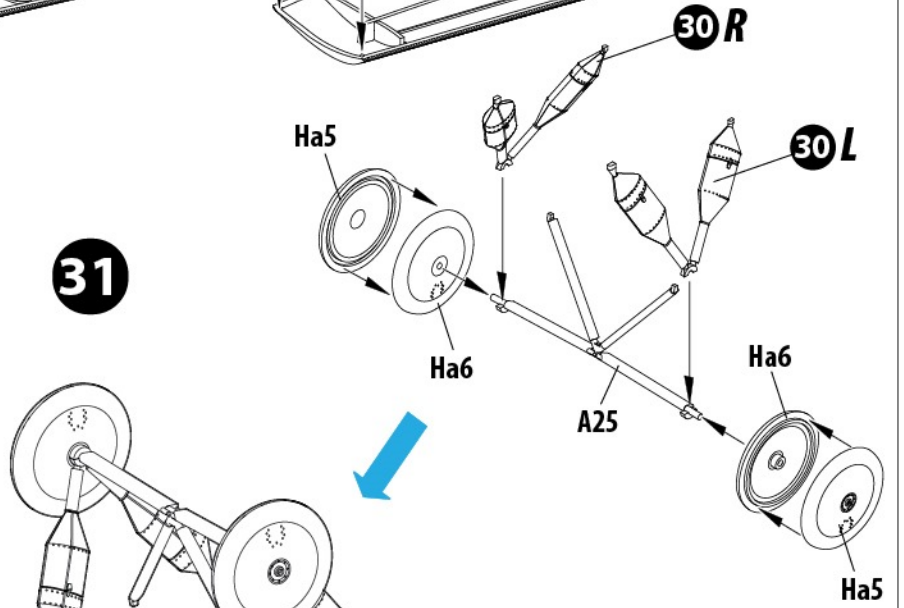

L

Ha4

Ha4

Ha2

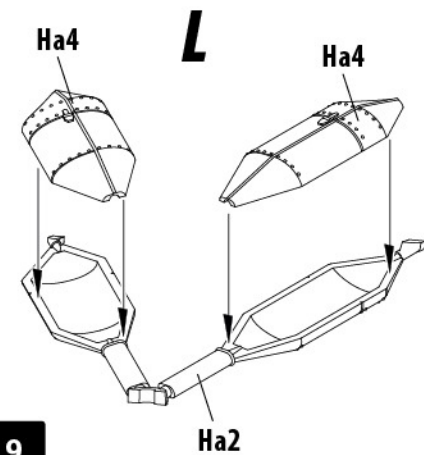

27

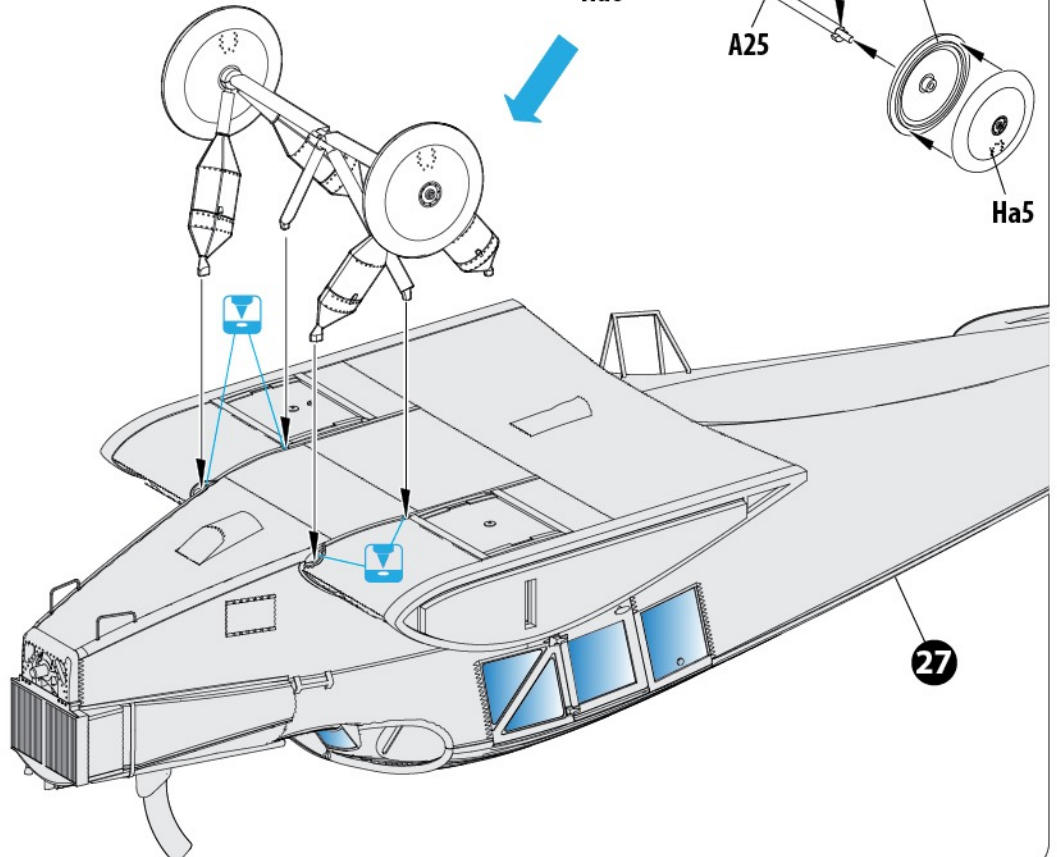

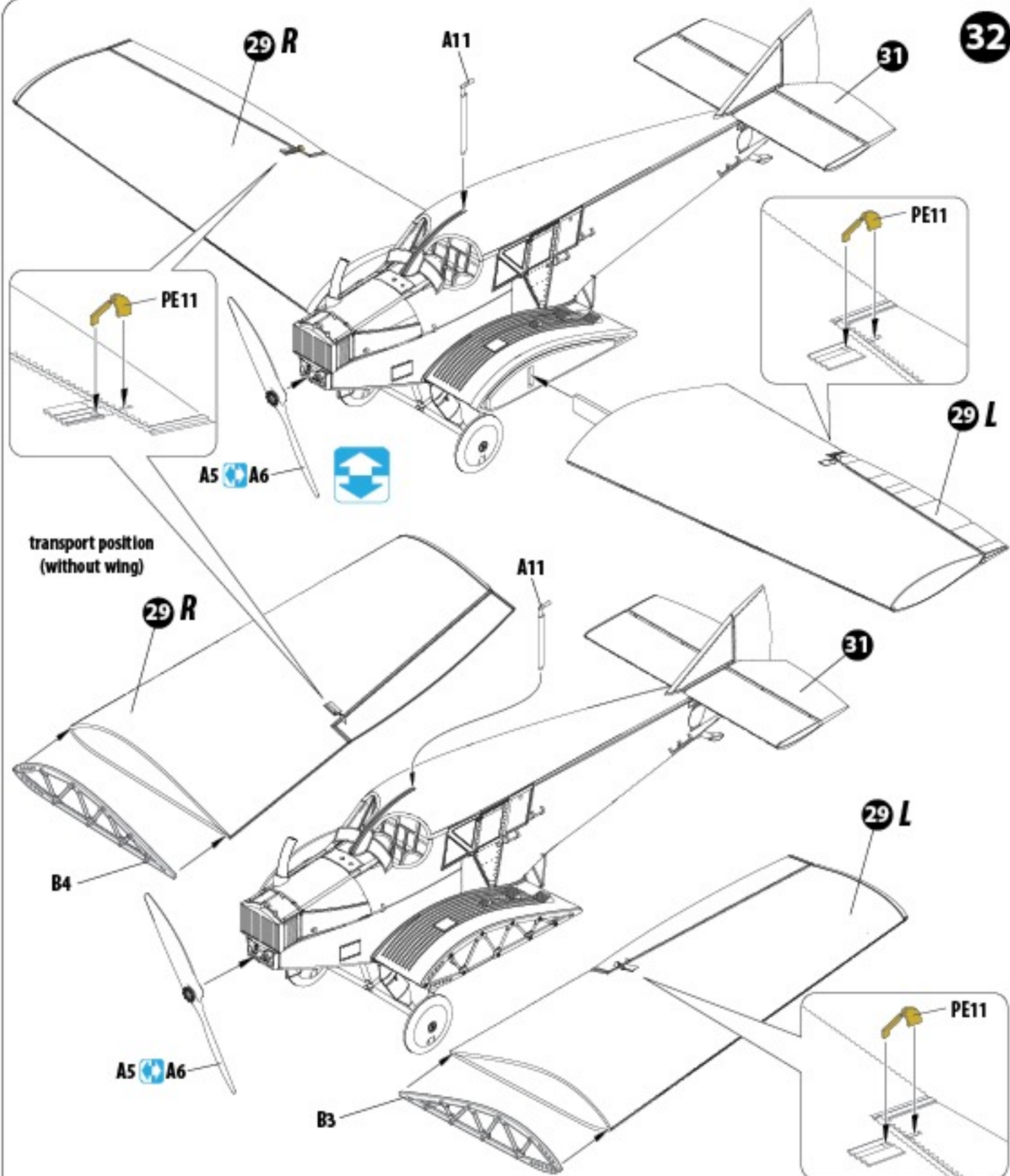

COLOR CHART

No	Color	Vallejo	Mr. Color	AK RC	Mission Models	AMMO MIG	Tamiya	Color name
01		71.074	C-318	RC-227	MMP-039	ATOM-20006	XF-59	Beige
02		71.062	C-090	RC-020	MMM-008	ATOM-20165	XF-16	Aluminum
03		71.057	C-033	RC-001	MMP-047	ATOM-20163	XF-01	Black
04		71.072	C-028	AK-476	MMM-002	ATOM-20166	XF-56	Steel
05		71.095	C-136	RC-047	MMP-009	ATOM-20083	XF-05	Green
06		71.041	C-310	RC-035	MMP-033	ATOM-20057	XF-10	Brown
07		71.027	C-043	RC-030	MMP-076	ATOM-20050	XF-79	Wood
08		71.078	C-004	RC-007	MMP-041	ATOM-20020	XF-03	Yellow
09		71.027	C-044	RC-030	MMO-060	ATOM-20051	XF-57	Light Brown
10		71.271	C-041	RC-067	MMP-015	ATOM-20032	XF-64	Dark Red
11		71.276	C-060	RC-299	MMP-072	ATOM-20124	XF-55	Light Grey
12		71.069	C-131	AK-709	MMW-001	ATOM-20054	XF-10	Rust
13		71.251	C-137	RC-022	MMP-040	ATOM-20159	XF-85	Tire Black
14		71.003	C-003	RC-006	MMP-003	ATOM-20029	XF-07	Red

2 D-188 "Dohle", Junkers-Flugzeugwerke AG, 1922



VOLODYMYR BOOTH 2024

3 Dz-33/D-154 „Reiher“ Aero-Targ Poznanchartered from Danziger Luftpost GmbH, 1921



VOLODYMYR BOOTH 2024