

CIERVA C.30 w/ WINTER SKI

41014

**GENERAL INSTRUCTION****SCALE
1:35**

- HIGHLY DETAILED MODEL
- CLEAR PARTS INCLUDED
- HATCHES CAN BE OPEN OR CLOSED
- PHOTO-ETCHED PARTS INCLUDED
- DECAL SHEET FOR 4 VARIANTS

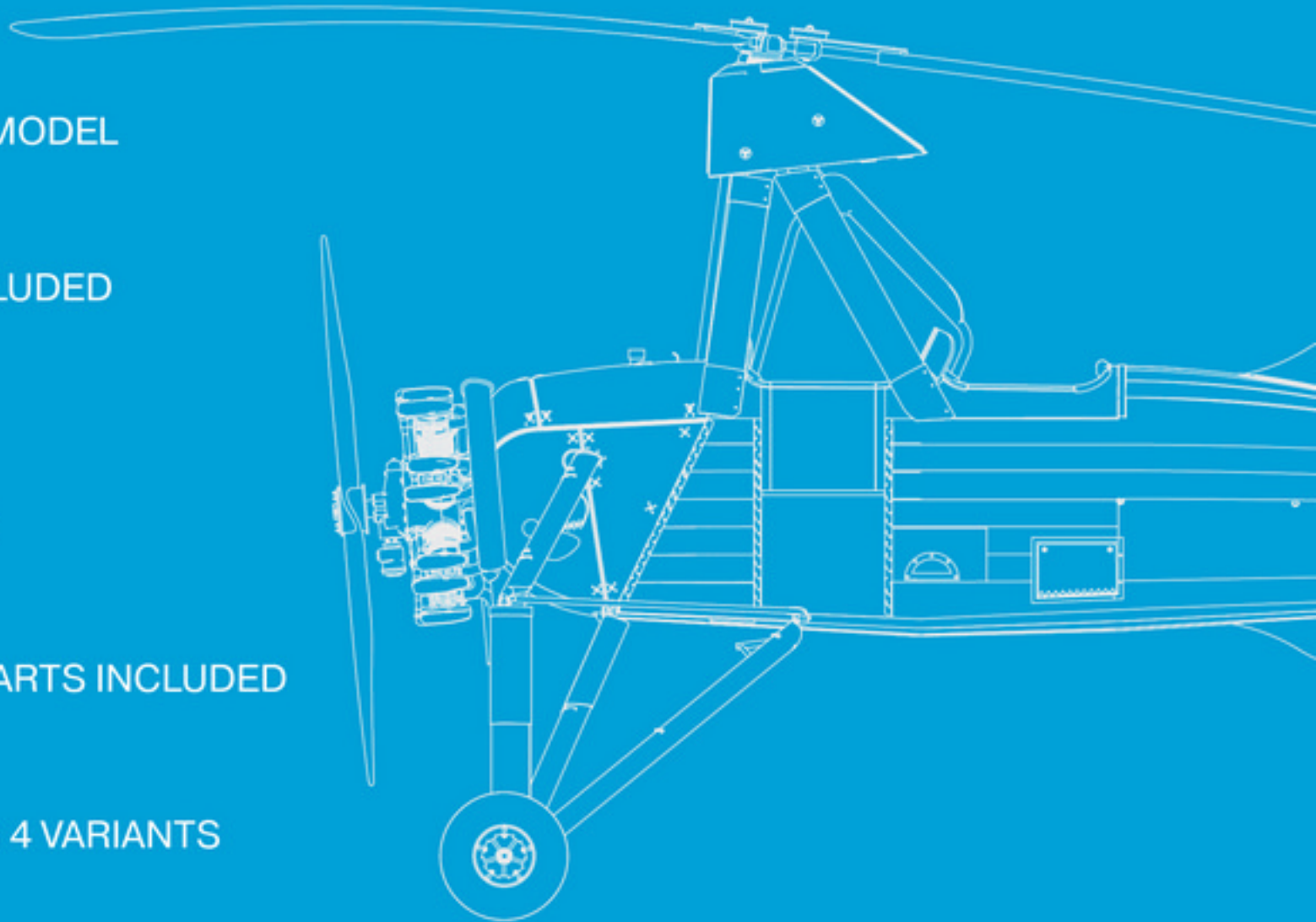

CIERVA C.30 w/ WINTER SKI

PAINTING GUIDE
ОКРАСКА

Autogyro of the commercial company "AB Autogiro".
Sweden, late 1930s.

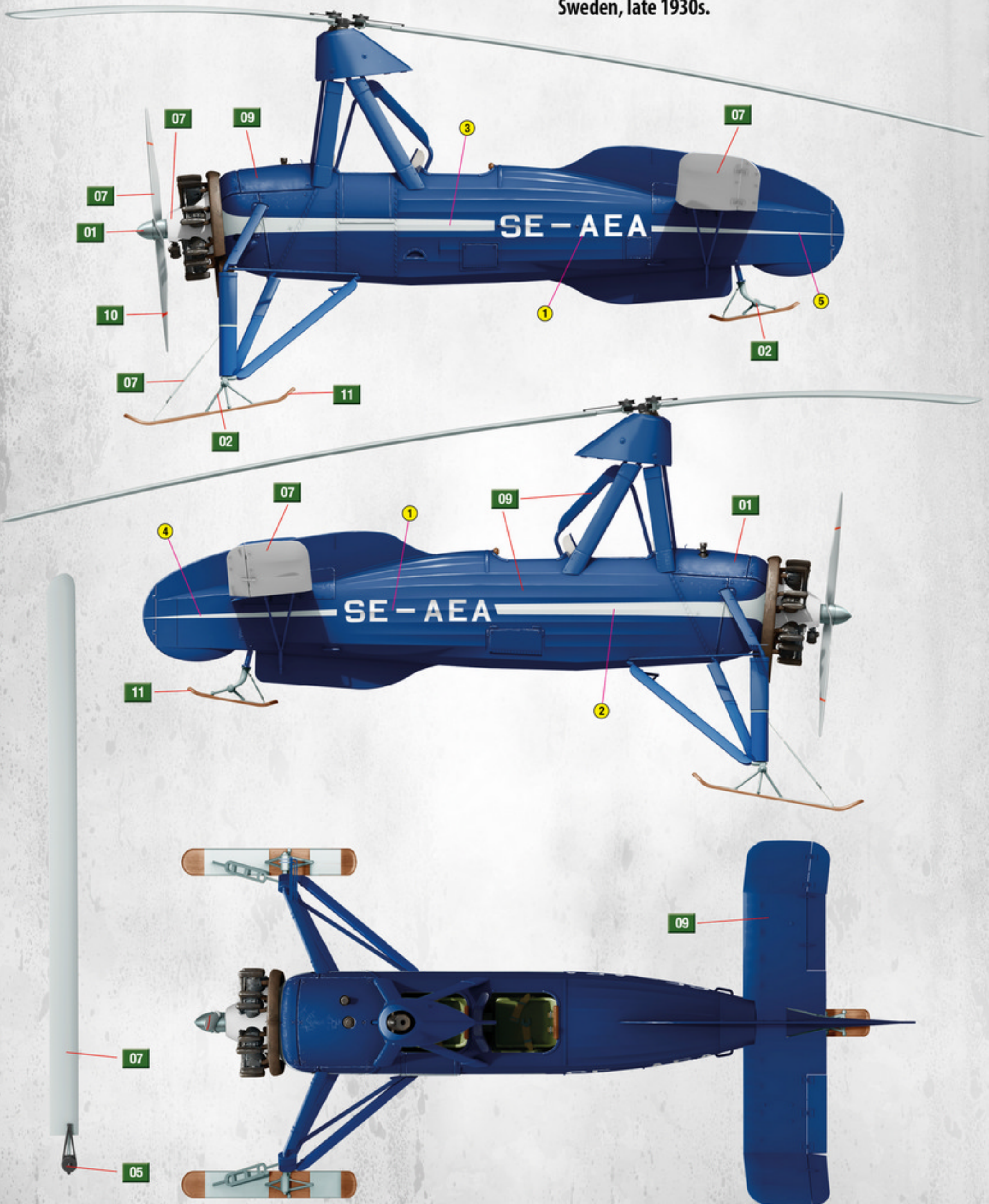

ATTENTION

Ne pas utiliser de colle ou de peinture à proximité d'une flamme nue, et aérer la pièce de temps en temps.
Pour retirer les pièces hors du cadre, utiliser des ciseaux spéciaux pour maquette le plastique en excès avec un cutter ou une lime.
Voir la fin de cette colonne pour la signification des symboles.
Après l'assemblage peut rester des pièces inutilisées.

ZUR BEACHTUNG

Kleber und Farbe nicht nahe von offenem Feuer verwenden und das Fenster von Zeit zu Zeit zur Belüftung öffnen.
Zum Abschneiden der Teile vom Verbundstück eine Modellierschere verwenden und die überstehenden Plastikteile mit einem Messer oder einer Feile beseitigen.
Die Bedeutung der Symbole finden Sie unten in dieser Spalte.
Nach dem Zusammenbau des Modells, können einzelne Teile übrig bleiben.

УВАГА

При використанні клею та фарб всі роботи проводити подалі від джерел вогню у приміщенні, що добре провітрюється.
Деталі відокремлювати від літників ножом або іншим ріжучим інструментом. Зачистити облой і місця зрізу за допомогою надфайлу та наждачного паперу. Будівництво моделі виконувати згідно зі схемою. Для зручності побудови кожна деталь позначена номером.
Після складання можуть залишитися невикористані деталі.

ATTENZIONE

Non usare colla a vernice vicino a fiamme esposte, e aprire le finestre di tanto in tanto per cambiare l'aria. Quando si staccano parti del carrello, usare forbici da modellismo e eliminare la plastica in eccesso con un coltello o una lima. Vedere in fondo a questa colonna per il significato dei simboli.
Dopo l'assemblaggio possono rimanere parti inutilizzate.

ВНИМАНИЕ

При использовании клея и красок все работы производить в проветриваемом помещении вдали от источников огня.
Детали отделять от литников ножом или другим режущим инструментом. Зачистить облой и места среза при помощи надфиля и наждачной бумаги. Сборку моделей производить согласно схеме сборки.
Для удобства сборки каждая деталь обозначена номером.
После сборки набора могут остаться неиспользованные детали.

CAUTION

When you use glue or paint, do not use near open flame, and use in well ventilated room. When you take parts off from the runner frame, use modeling scissors or cutter.
See the bottom of this column for the meaning of symbols.
Extra details can remain after assembling of the kit.



MAKE 2PCS
2 TEILE FERTIGEN
EFFECTUER 2 PIECES
FARE DUE PEZZI
TEE 2 KPL.
GOR 2 ST.
ПОВТОРИТЬ ДВА РАЗА
КІЛЬКІСТЬ РАЗІВ



DO NOT CEMENT
NICHT KLEBEN
NE PAS COLLER
NON INCOLLARE
EIJUMAA
LIMMAEJ
НЕ ИСПОЛЬЗОВАТЬ КЛЕЙ
НЕ КЛЕІТИ



OPTIONAL
NACH BELIEBEN
FACULTATIF
FACOLTATIVO
VALINNANVARAINEN
VALBAR
ВАРИАНТИ



OPEN HOLE
OFFNEN
FAIRE UN TROU
FORO APERTO
AVAK REIKÄ
ÖPPNÄ HALET
СДЕЛАТЬ ОТВЕРСТИЕ
ЗРОБИТИ ОТВІР



REMOVE
ENTFERNEN
RETIRER
SEPARARE
POISTA
AVLÄGSNA
OTREZATI
ВІДРІЗАТИ



BEND
BITTE BIEGEN
PLIER S'IL VOUS PLAÎT
PIEGARE
TAITA
ВОСКА
ВЫГНУТИ

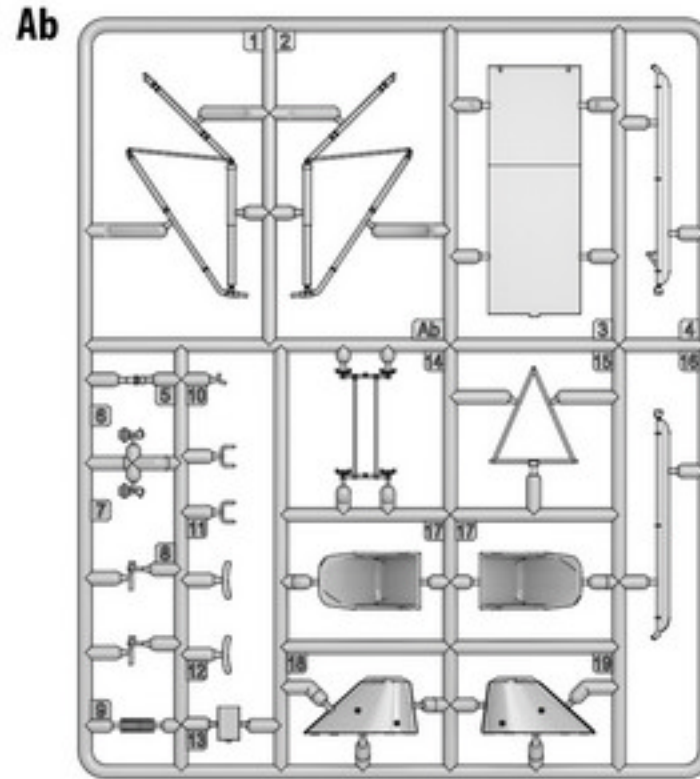
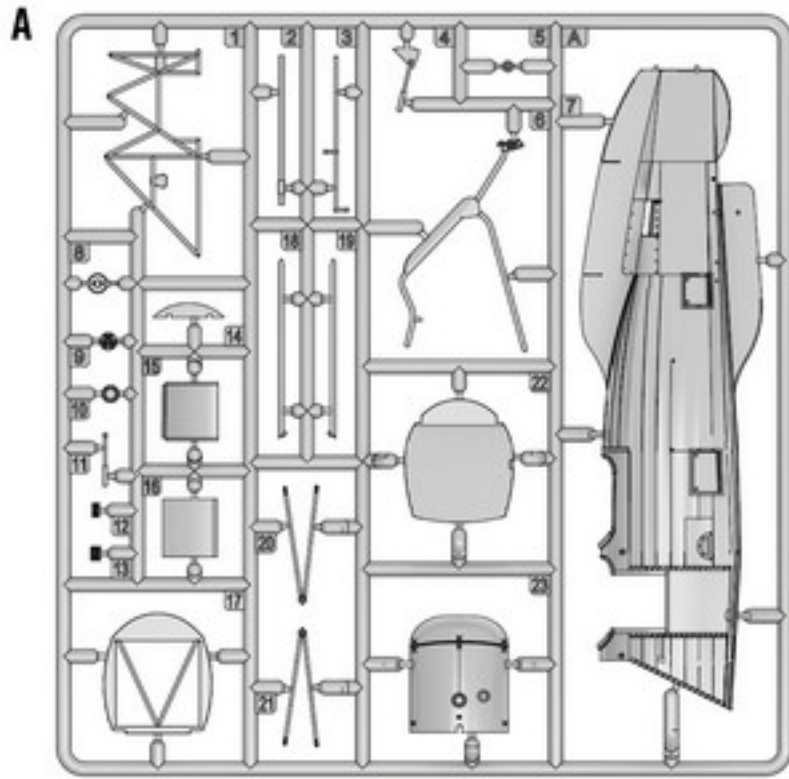
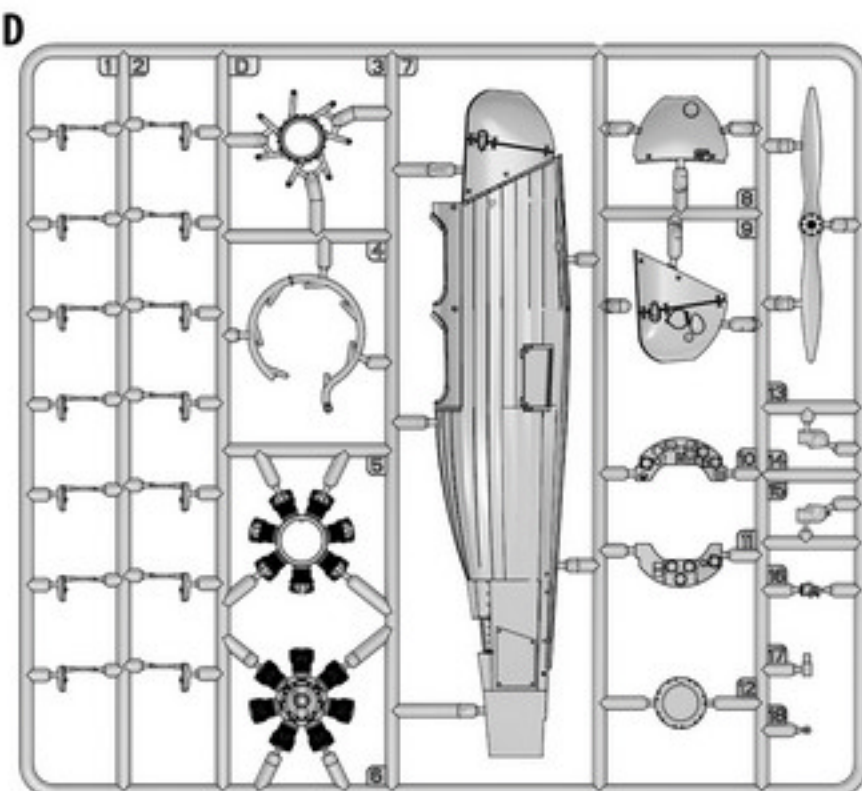
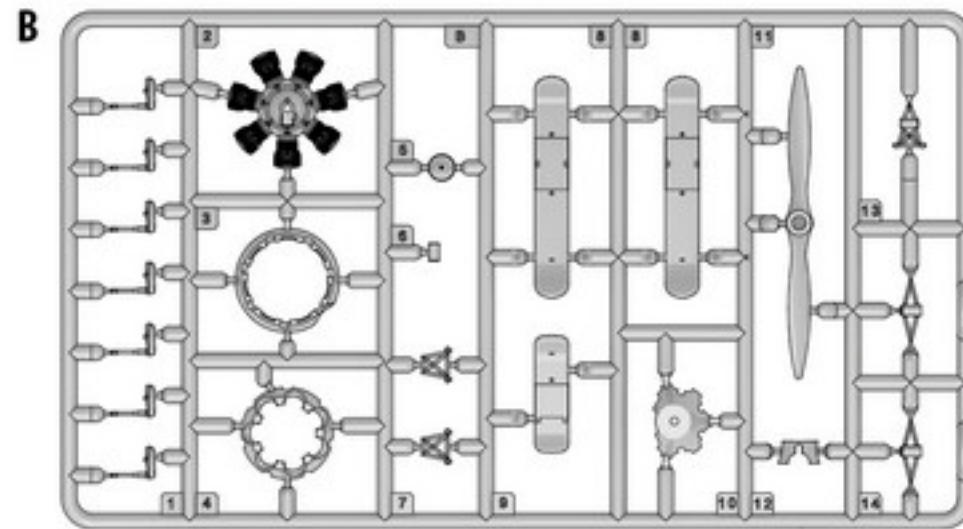
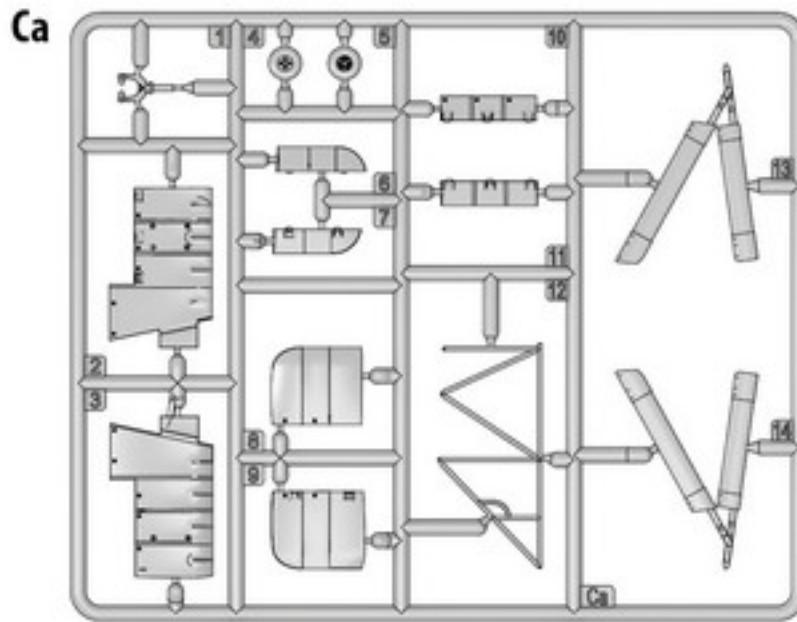

SCRATCHBUILD
AM MEISTEN ZU MACHEN
FAIRE LE PLUS
RENDITI
TEE ITSE
GOR DIG SJÄLV
СДЕЛАТЬ САМОМУ
ЗРОБИТИ САМОМУ

PARTS/ДЕТАЛИ**C CLEAR PARTS****Ac x3****PE PHOTO-ETCHED PART**

Деталі фототравлення

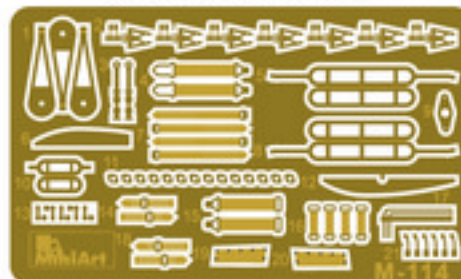
**Decal sheet**

Деколи

**COLORS CHART**

Nr	Color/Цвет	Vallejo	Mr. Color	Life Color	Tamiya	AK	Mission Models	Hataka	AMMO MIG	Color name
01		70.997	090	LC-074	XF-16	RC-020	MMM-008	139	A.MIG-0194	Aluminium
02		70.884	028	LC-024	XF-56	AK-457	MMM-002	033	A.MIG-0191	Steel
03		70.984	131	UA-701	XF-10	AK-709	MMW-001	130	A.MIG-0041	Dark Rust
04		70.894	136	UA-059	XF-67	RC-047	MMP-009	021	A.MIG-0916	Green
05		70.950	033	LC-002	XF-01	RC-001	MMP-047	041	A.MIG-0046	Black
06		70.883	078	LC-078	XF-84	RC-015	MMM-001	106	A.MIG-0045	Gun Metal
07		70.951	062	LC-001	XF-02	RC-004	MMP-001	043	A.MIG-0050	White
08		70.821	044	UA-015	XF-55	RC-018	MMP-016	014	A.MIG-0030	Sand Yellow
09		70.965	005	LC-010	XF-17	RC-036	MMP-065	255	A.MIG-0086	Blue
10		70.957	003	LC-006	XF-07	RC-006	MMP-003	103	A.MIG-0049	Red
11		70.311	043	UA-714	XF-78	RC-029	MMP-076	013	A.MIG-0037	Wood

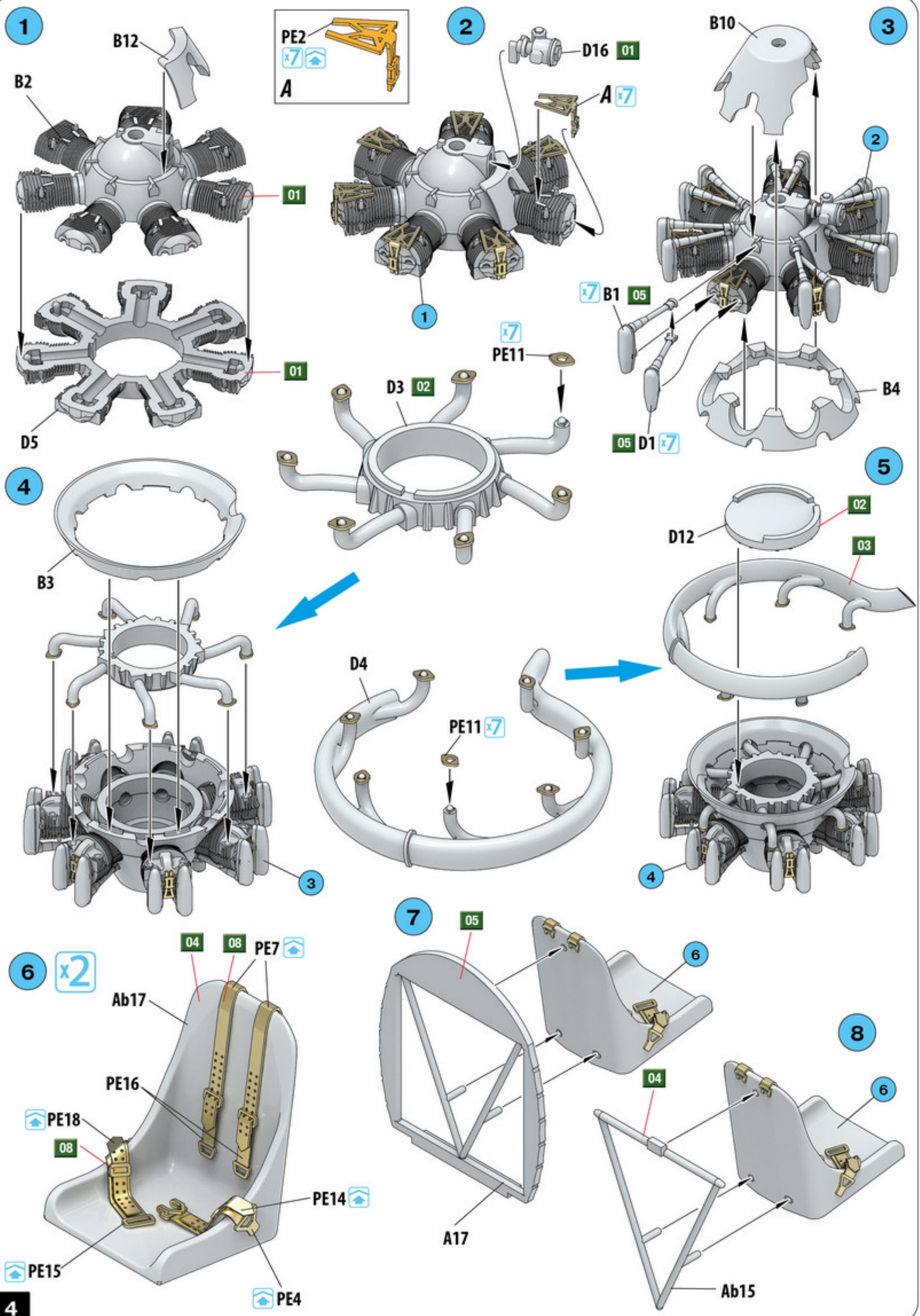

9

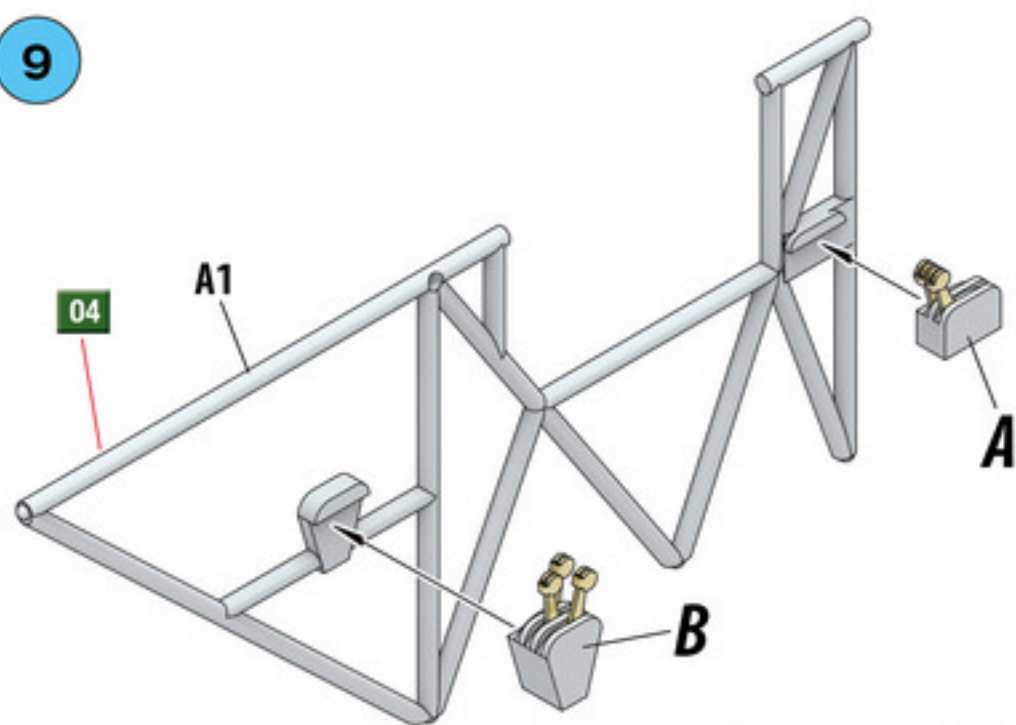

A

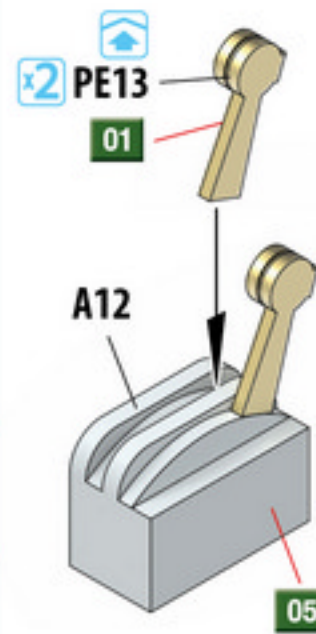

B

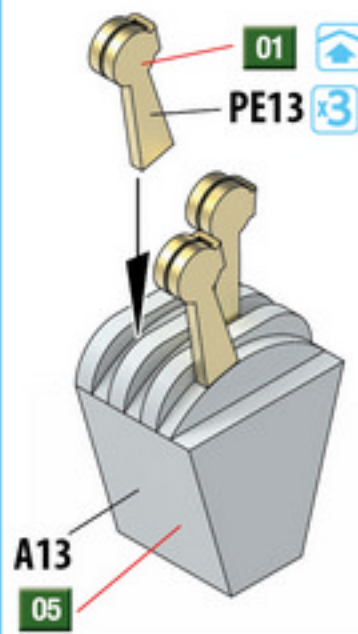

● Decal

10

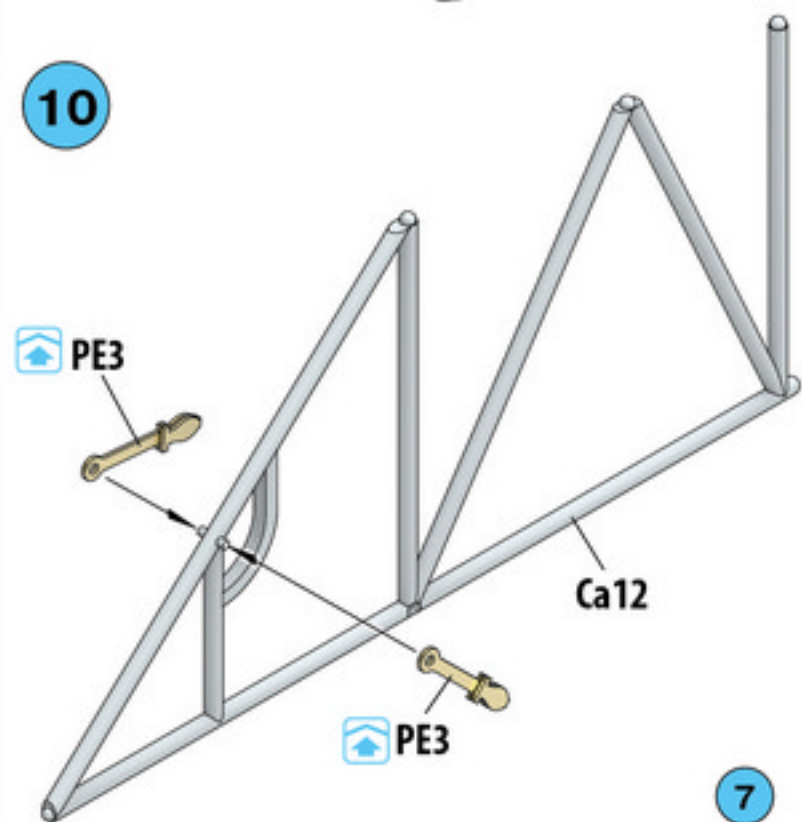

11

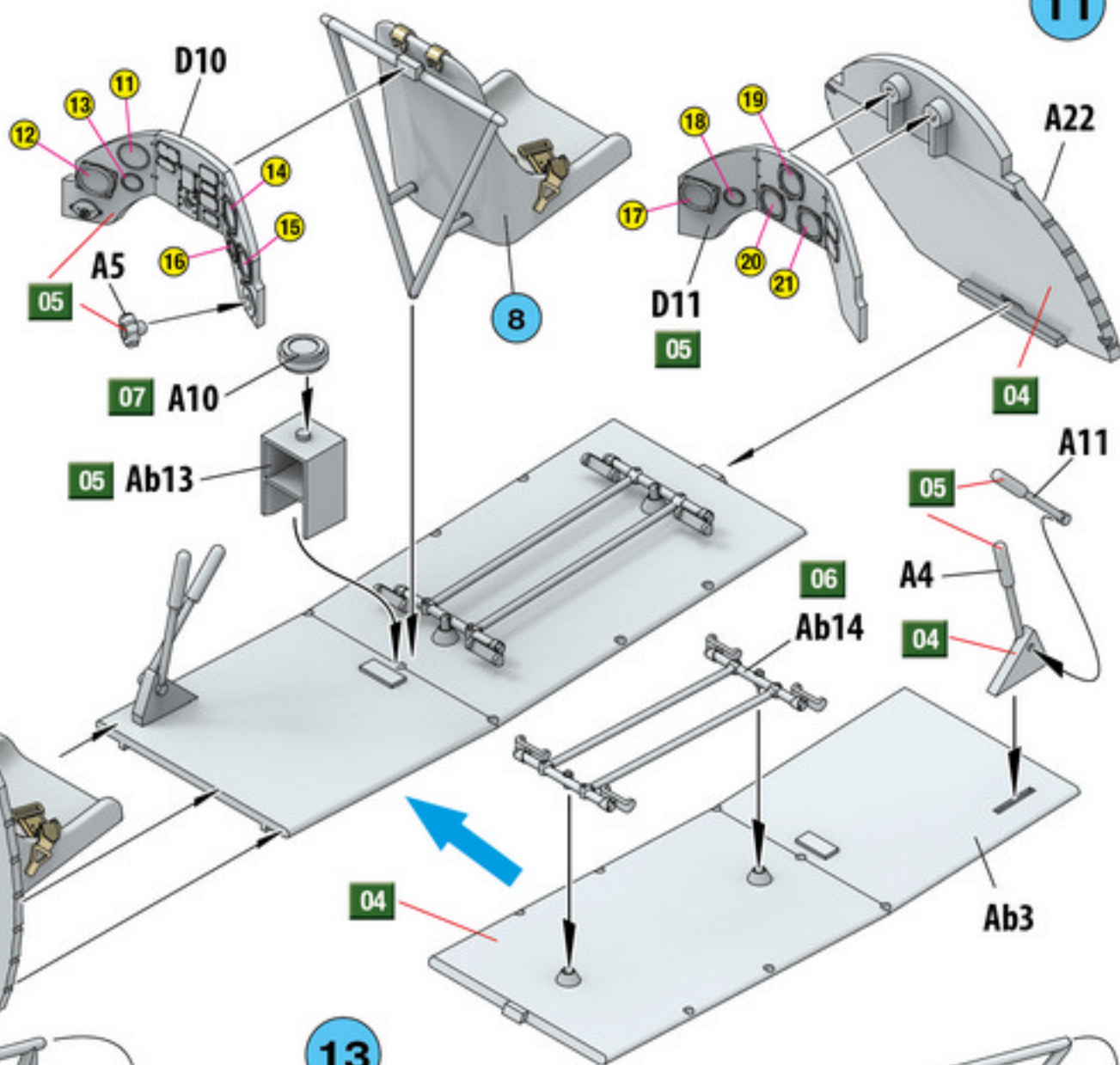

12

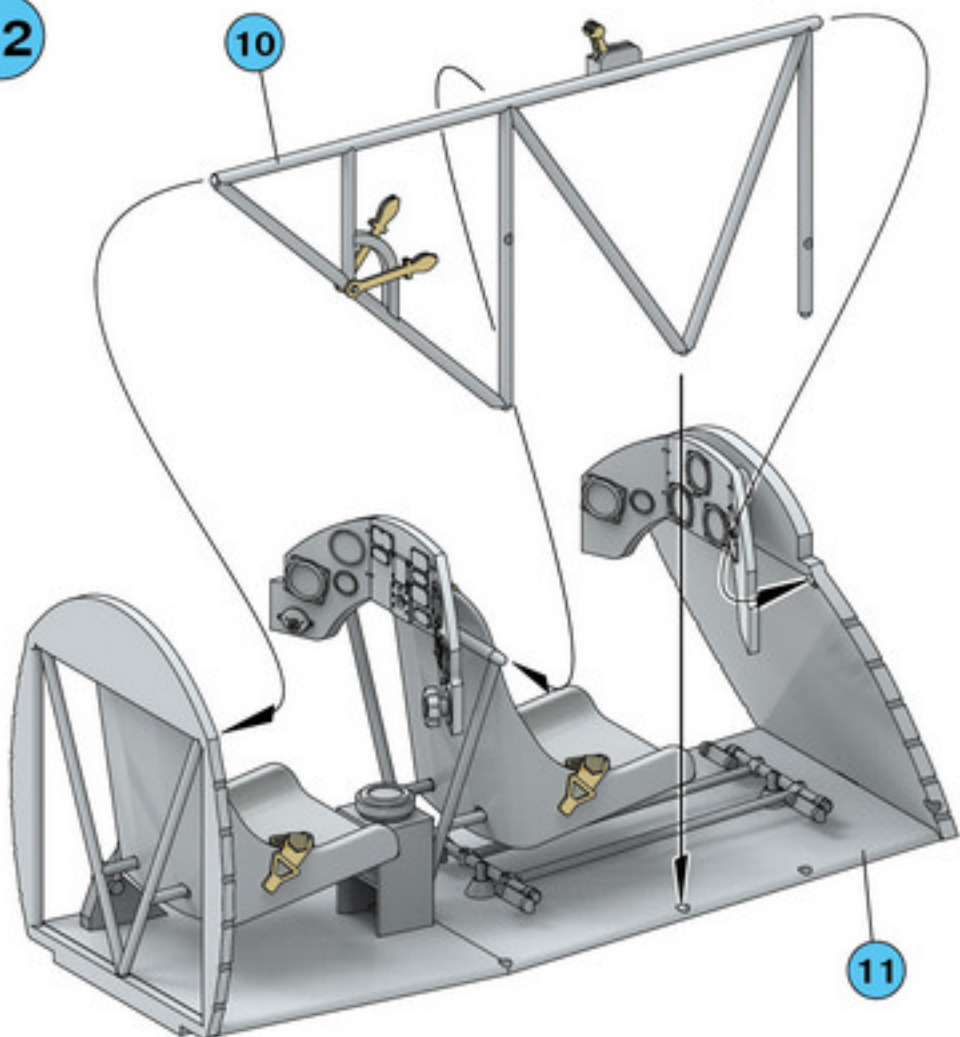

13

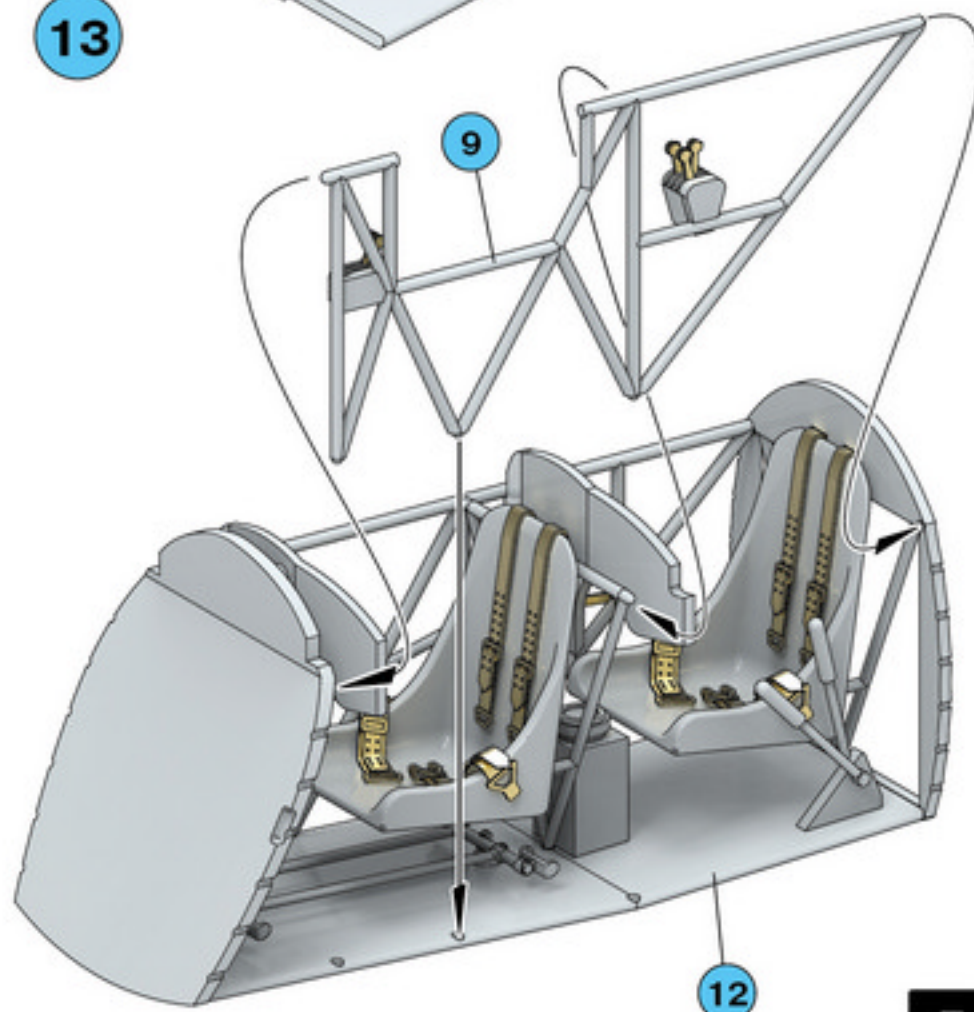

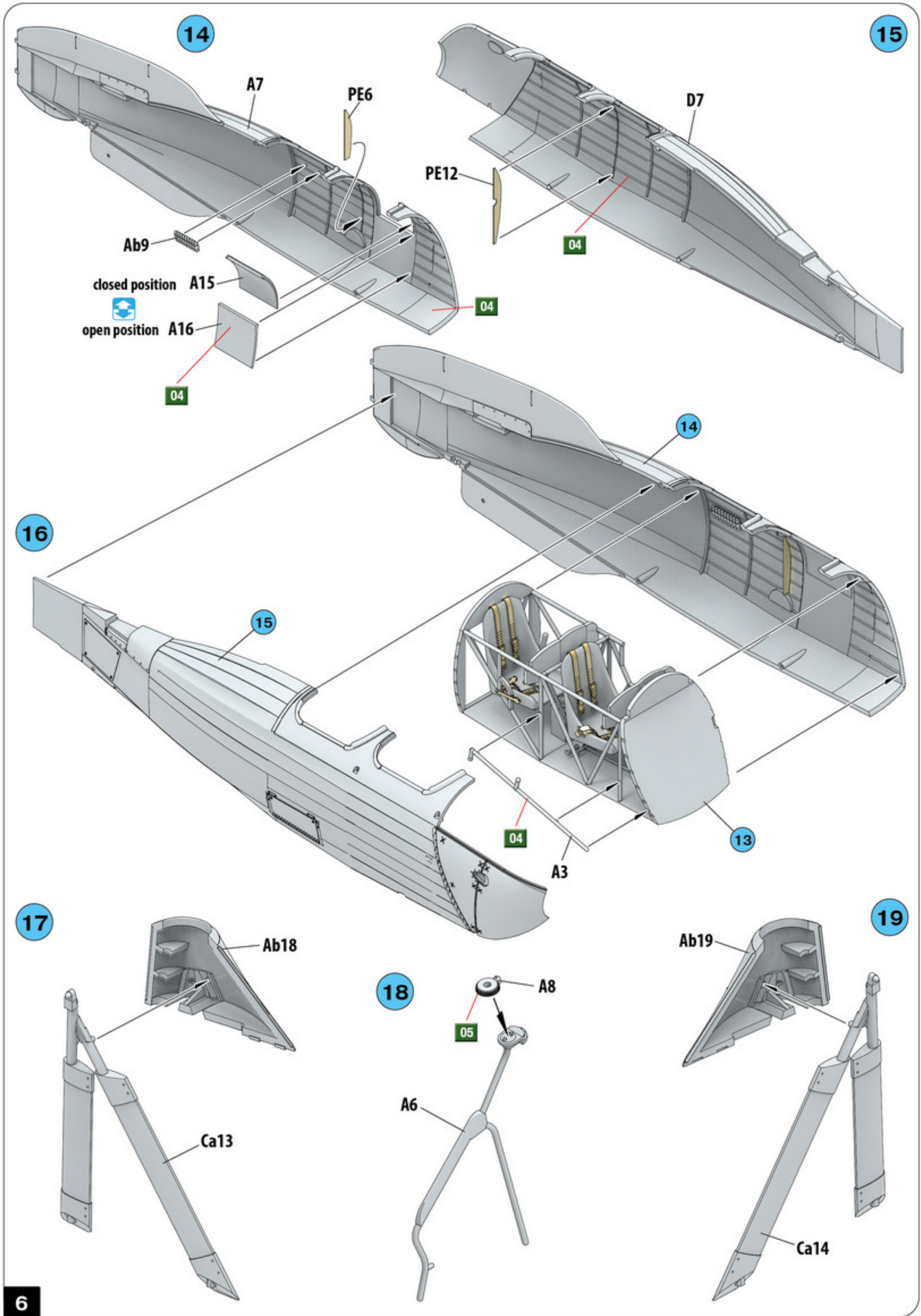

20

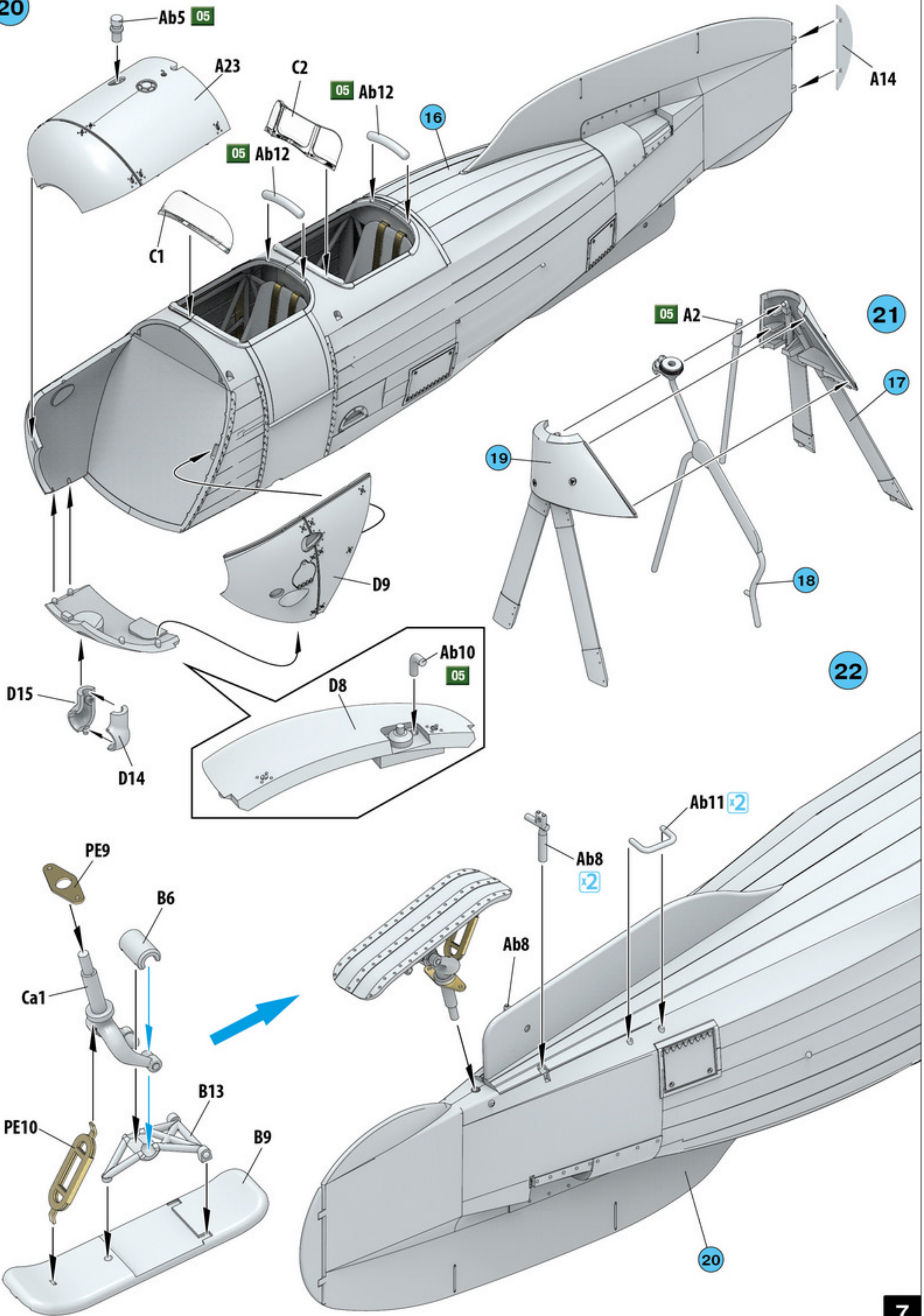

23

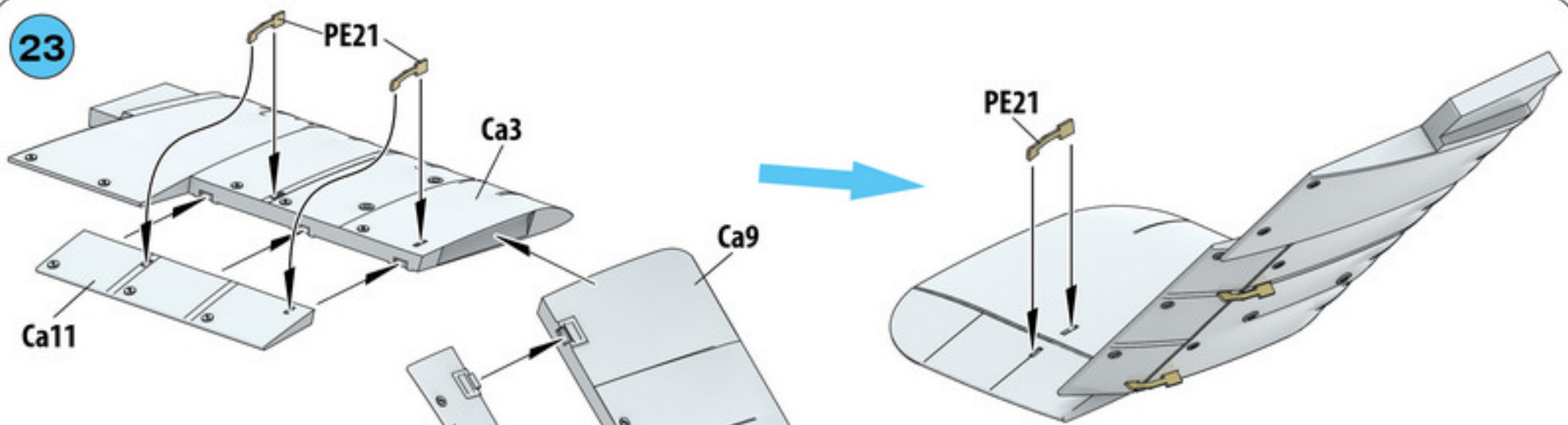

24

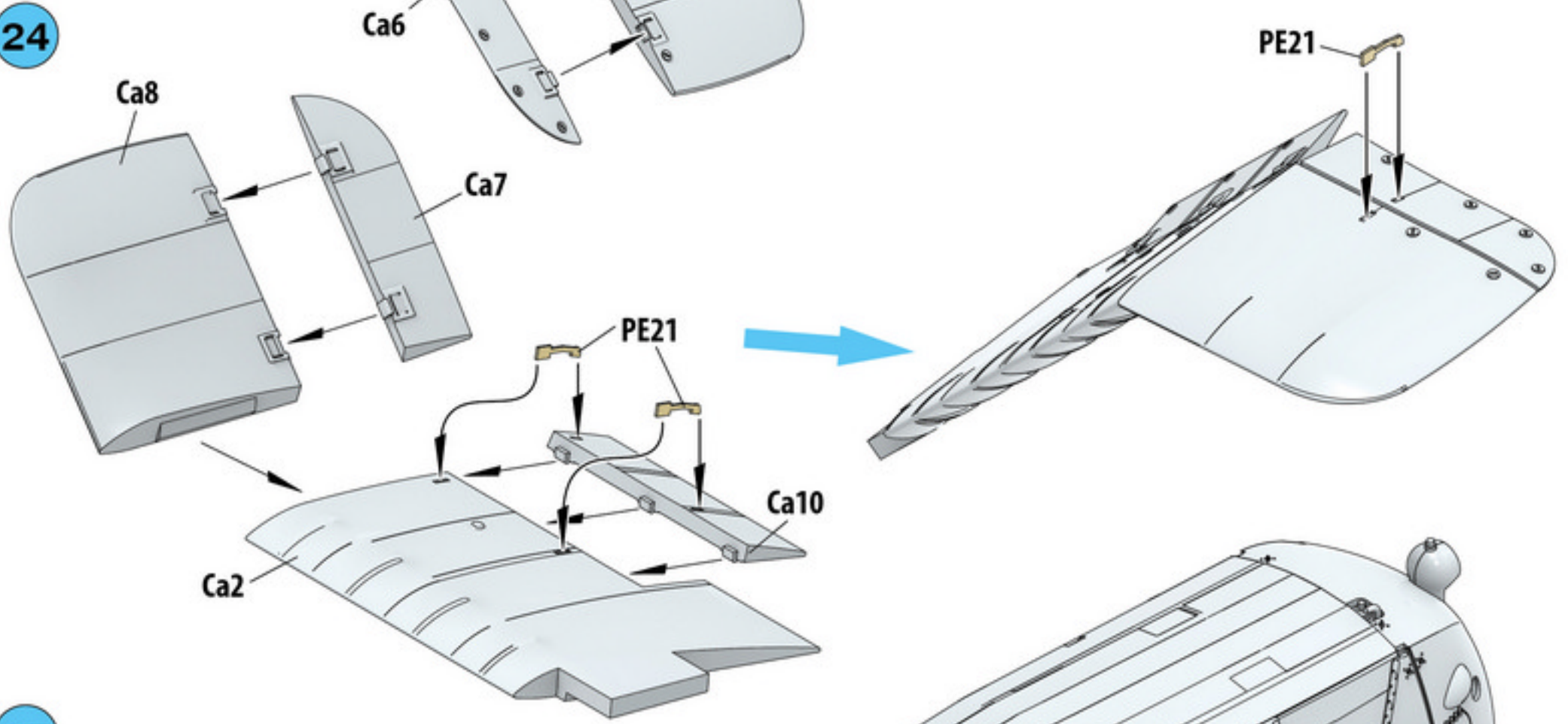

25

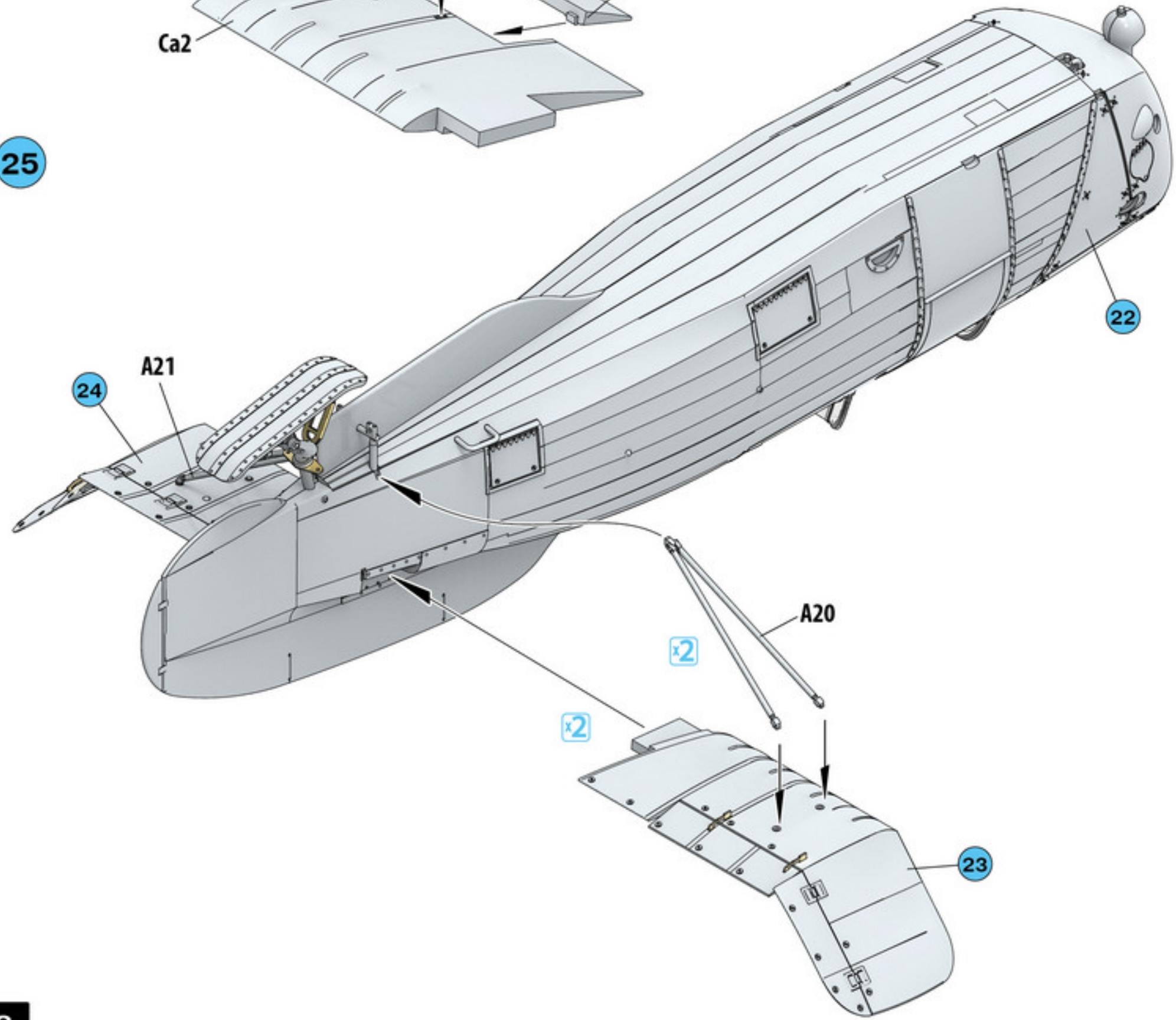

26

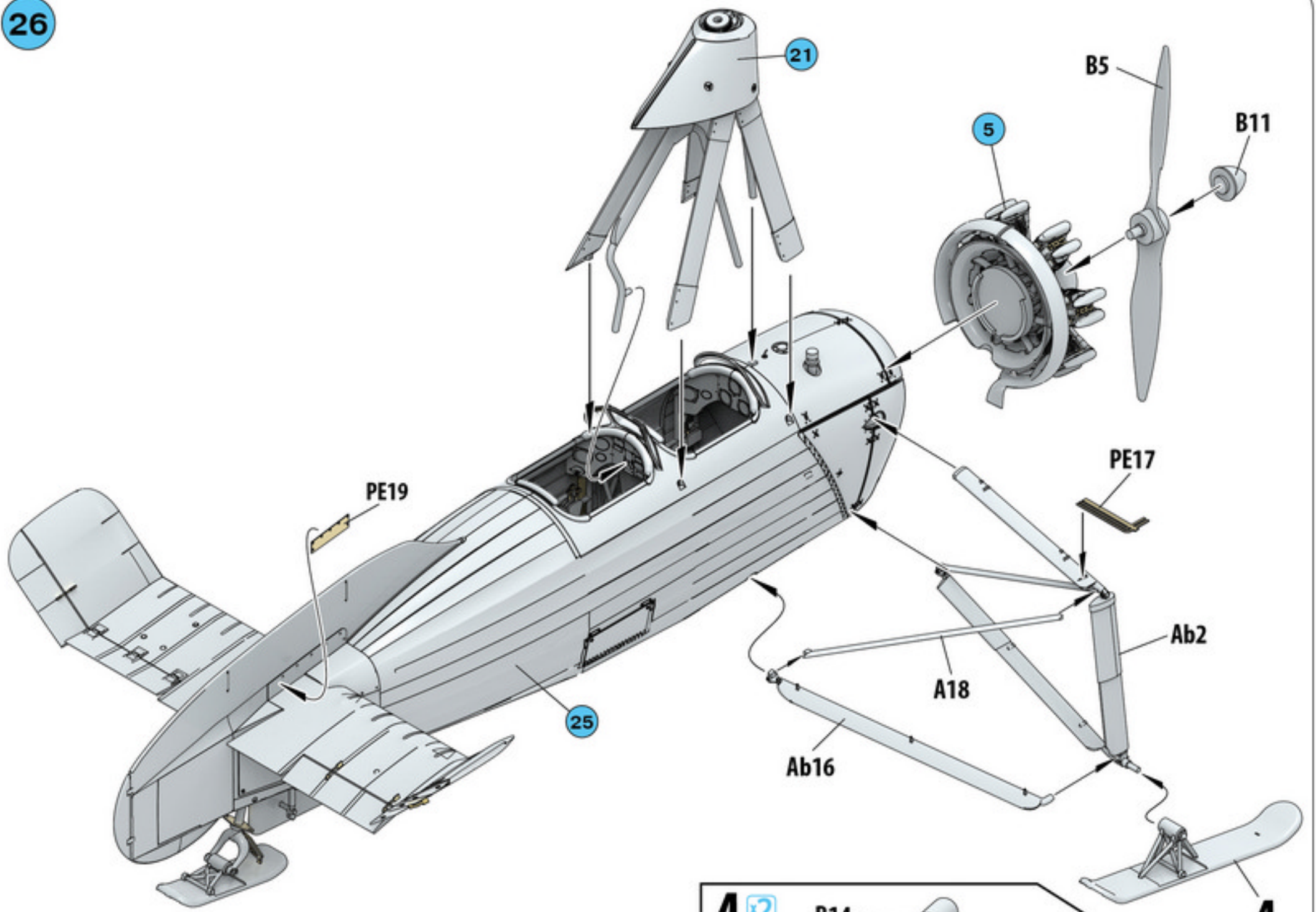

27

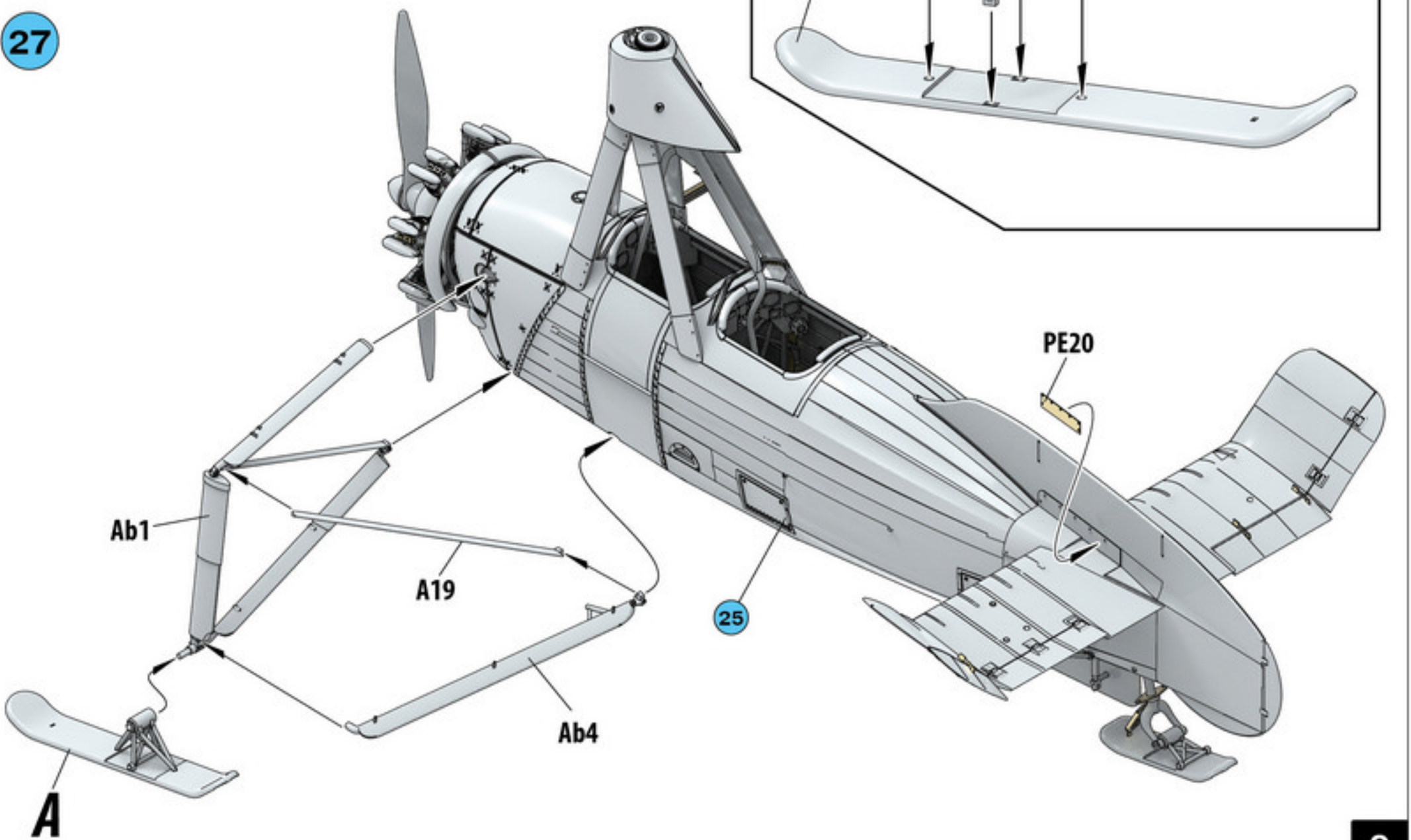

FLYING POSITION

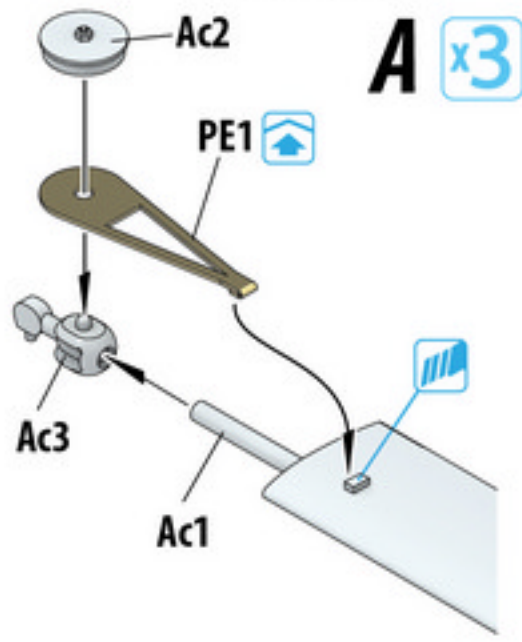

28



B

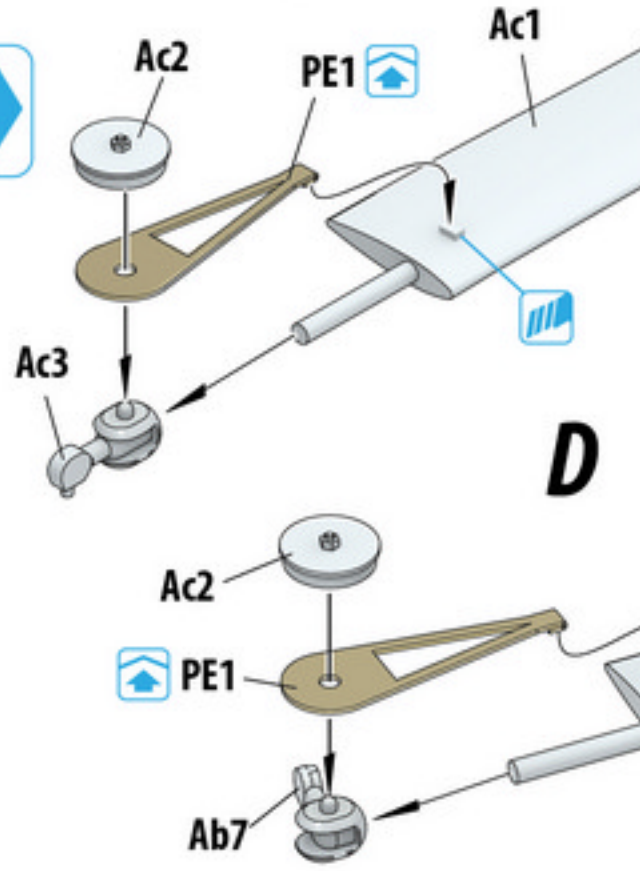

TRANSPORT POSITION

C

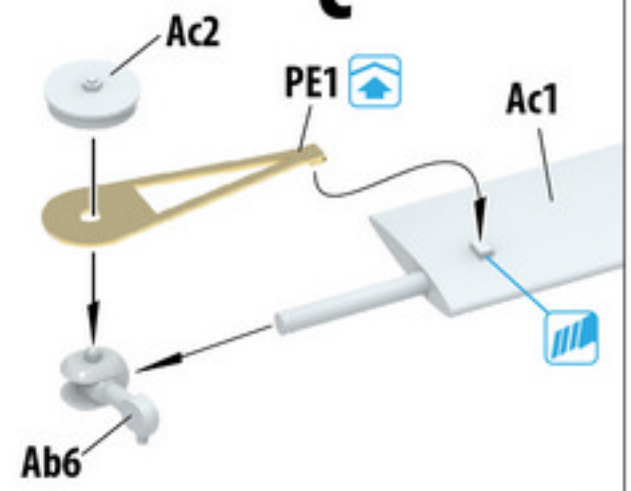

D

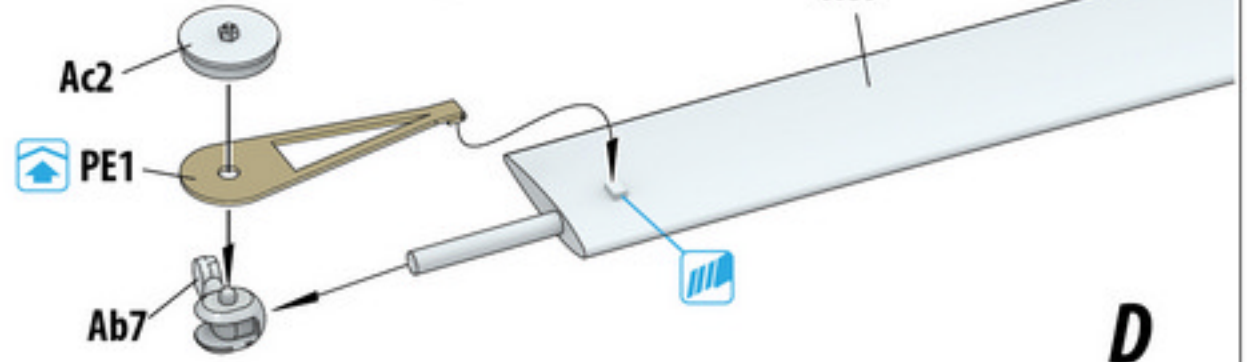

A

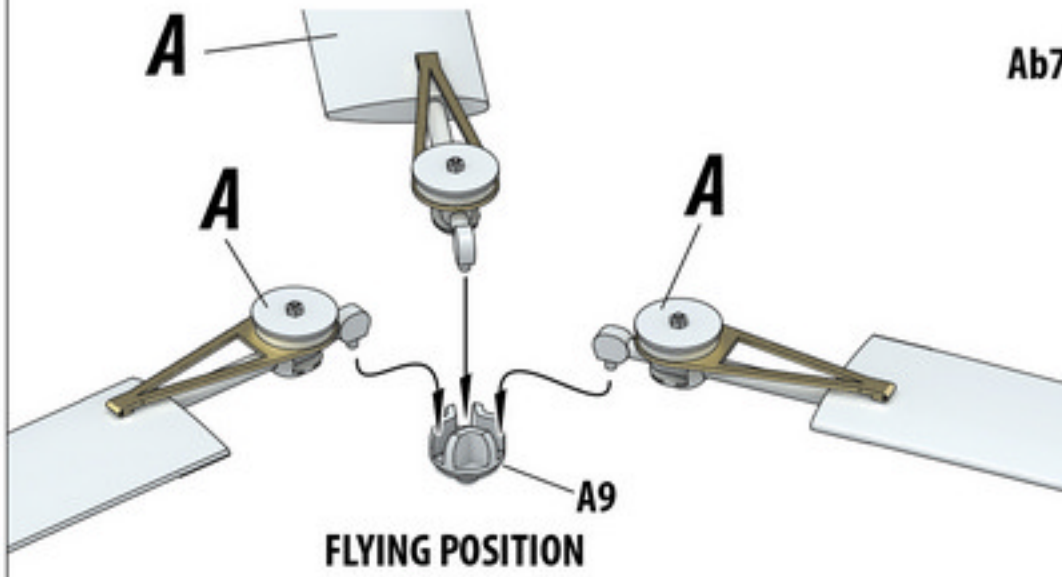

FLYING POSITION

29

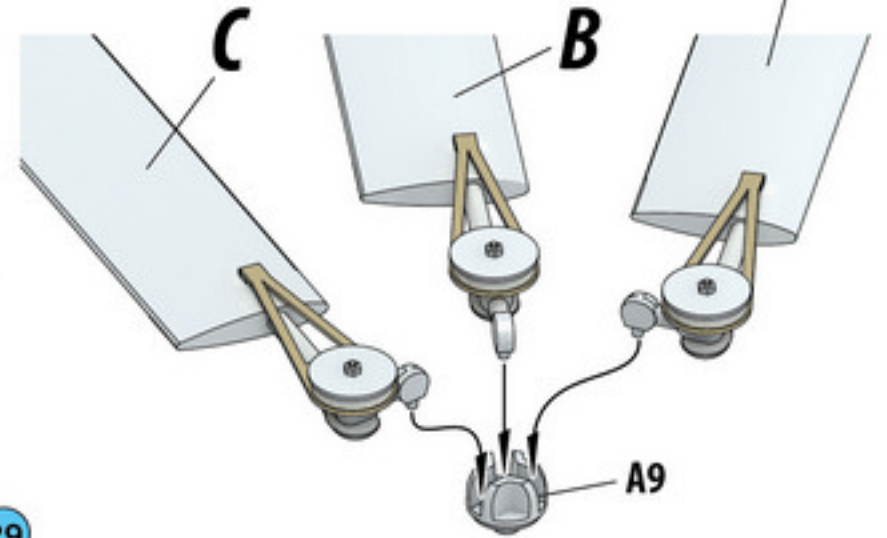

TRANSPORT POSITION

30

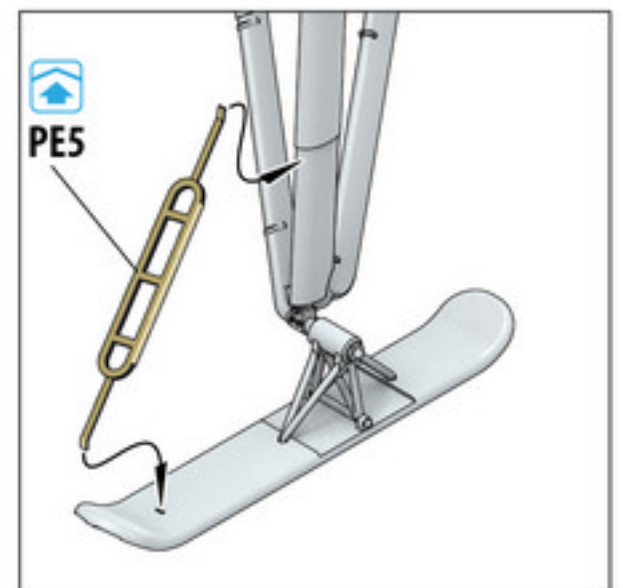
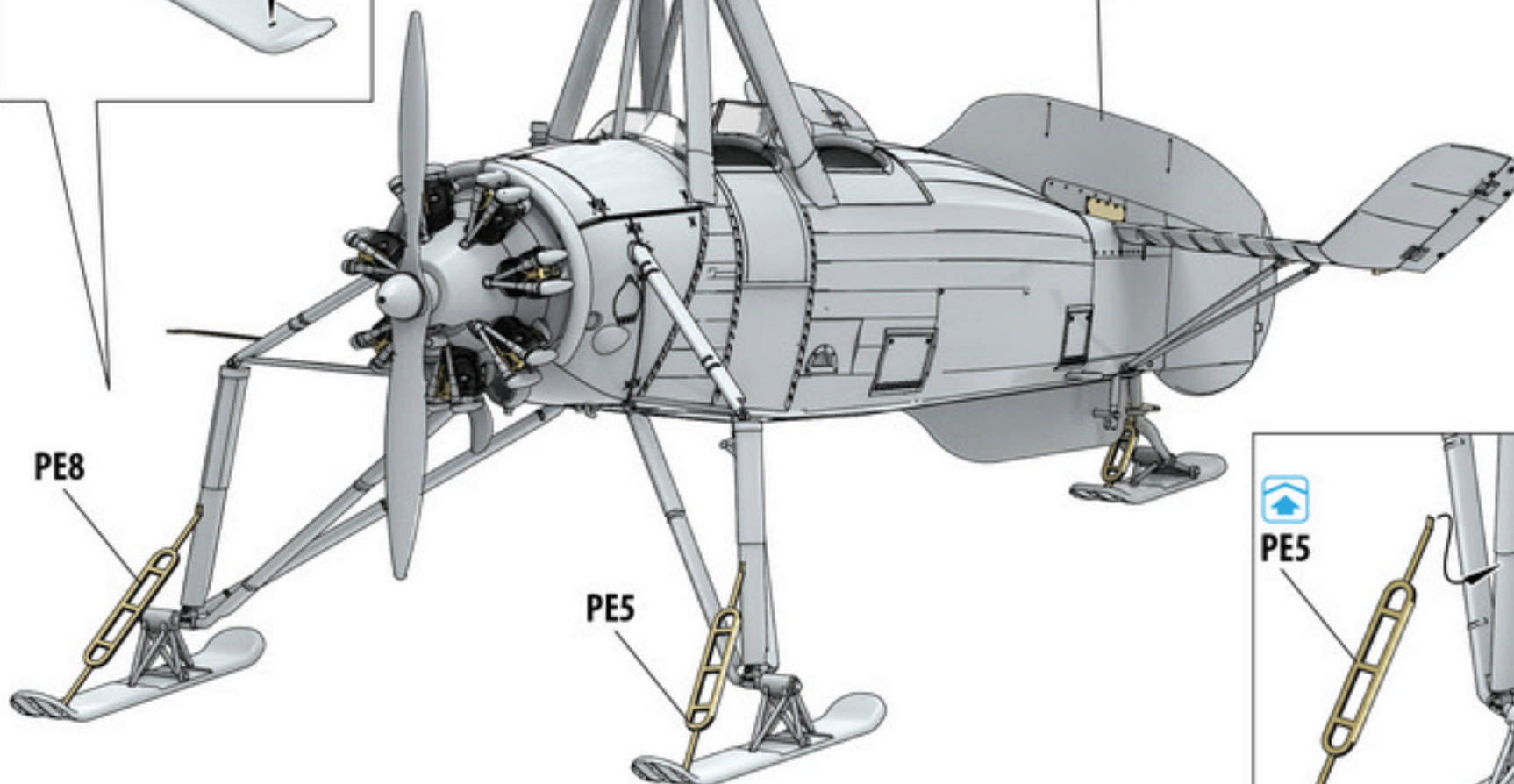
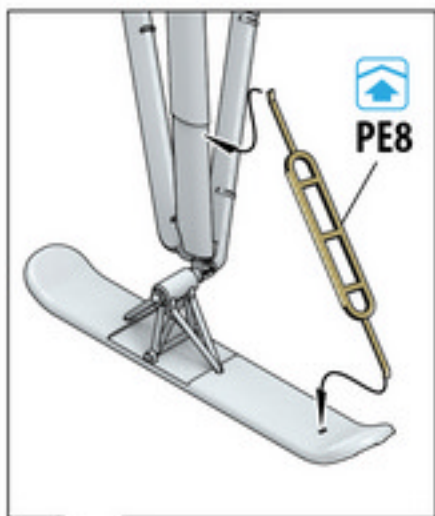

CIERVA C.30 w/ WINTER SKI

PAINTING GUIDE
ОКРАСКА

Commercial Autogyro in the service of the Swedish navy.
The early 1940s. The Swedish state flag is applied
as a sign of non-combatant during WWII.

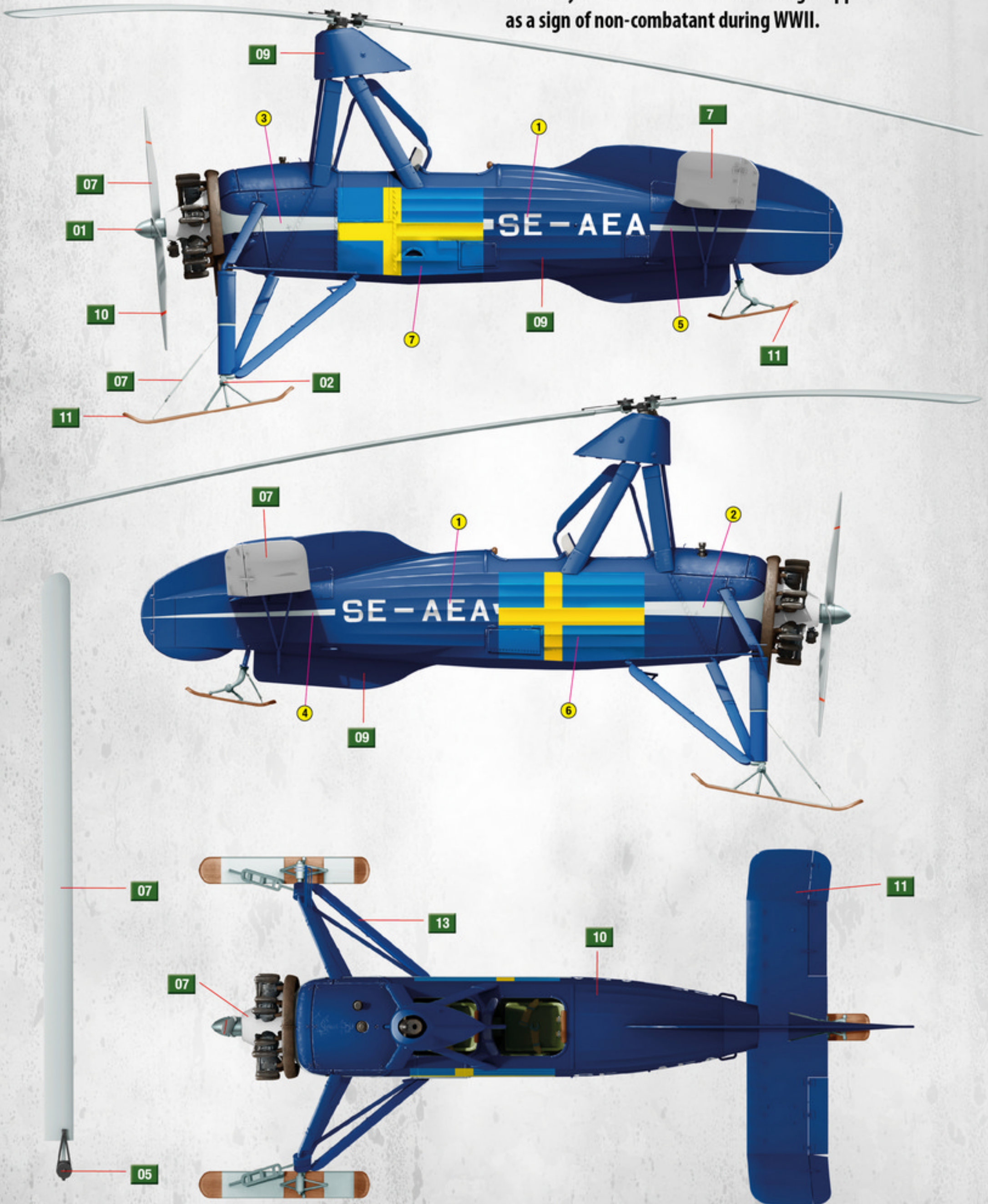

CIERVA C.30 w/ WINTER SKI

PAINTING GUIDE
ОКРАСКА

Autogyro of the commercial company "AB Autogiro".
Sweden, the late 1940s.

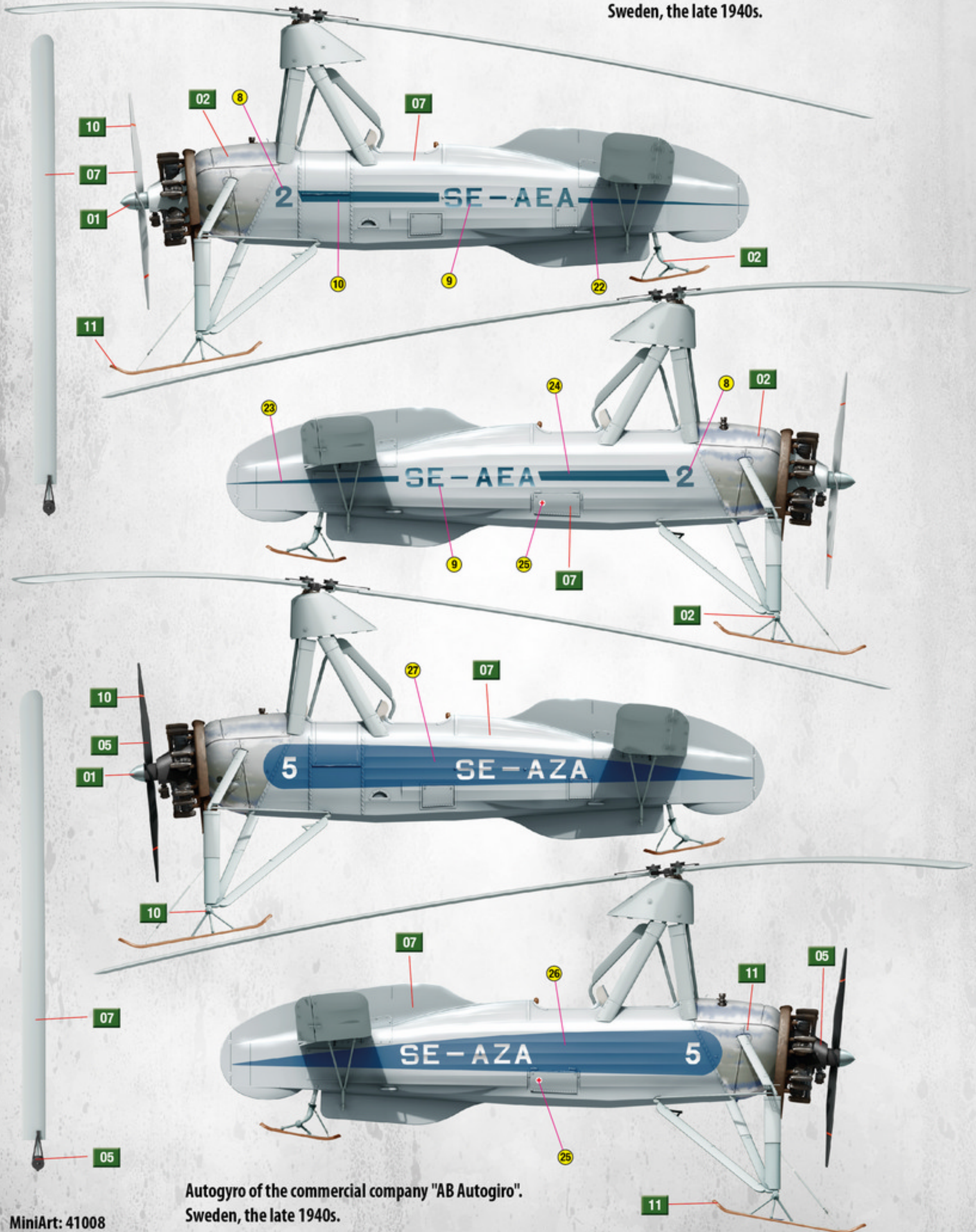

Autogyro of the commercial company "AB Autogiro".
Sweden, the late 1940s.