

SOVIET RAILWAY WAGON "ТЕПЛУШКА"

35300



GENERAL INSTRUCTION

- HIGHLY DETAILED MODEL
- DOORS & WINDOWS, CAN BE POSED OPEN OR CLOSED
- CAN BE INSTALLED ON EUROPEAN OR RUSSIAN RAILWAY GAUGE
- WORKABLE WHEELS
- PHOTO-ETCHED PARTS INCLUDED
- DECAL SHEET FOR 7 VARIANTS
- RAILWAY TRACK (RUSSIAN GAUGE) INCLUDED

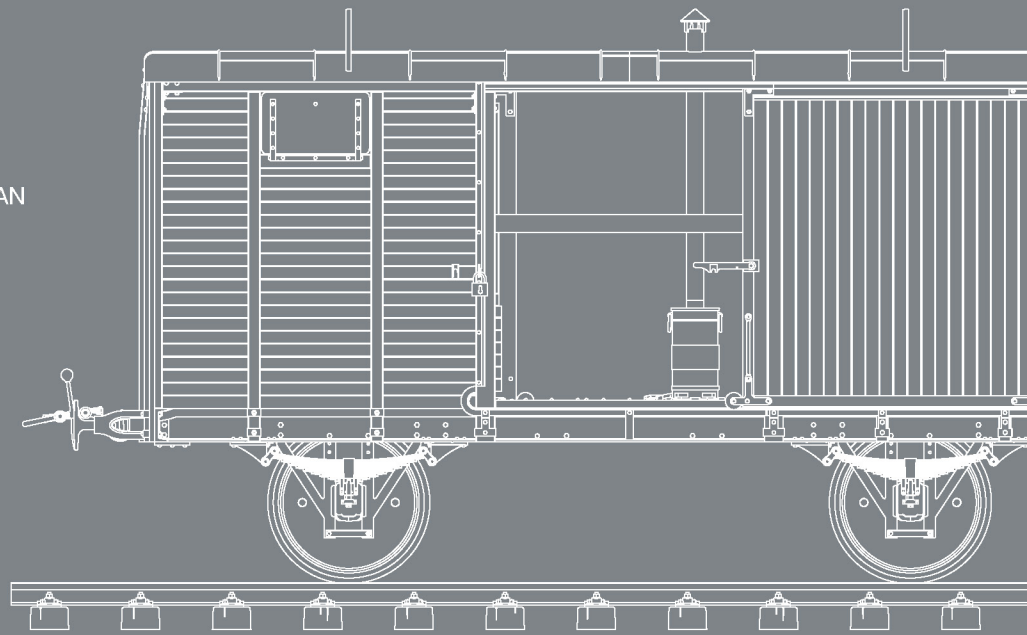

PAINTING GUIDE ОКРАСКА

- 1** **Kuibyshev Railroad. Railway carriage as a part of a military train, 1942.**
Железная дорога им. Куйбышева. Вагон в составе воинского эшелона 1942 год.

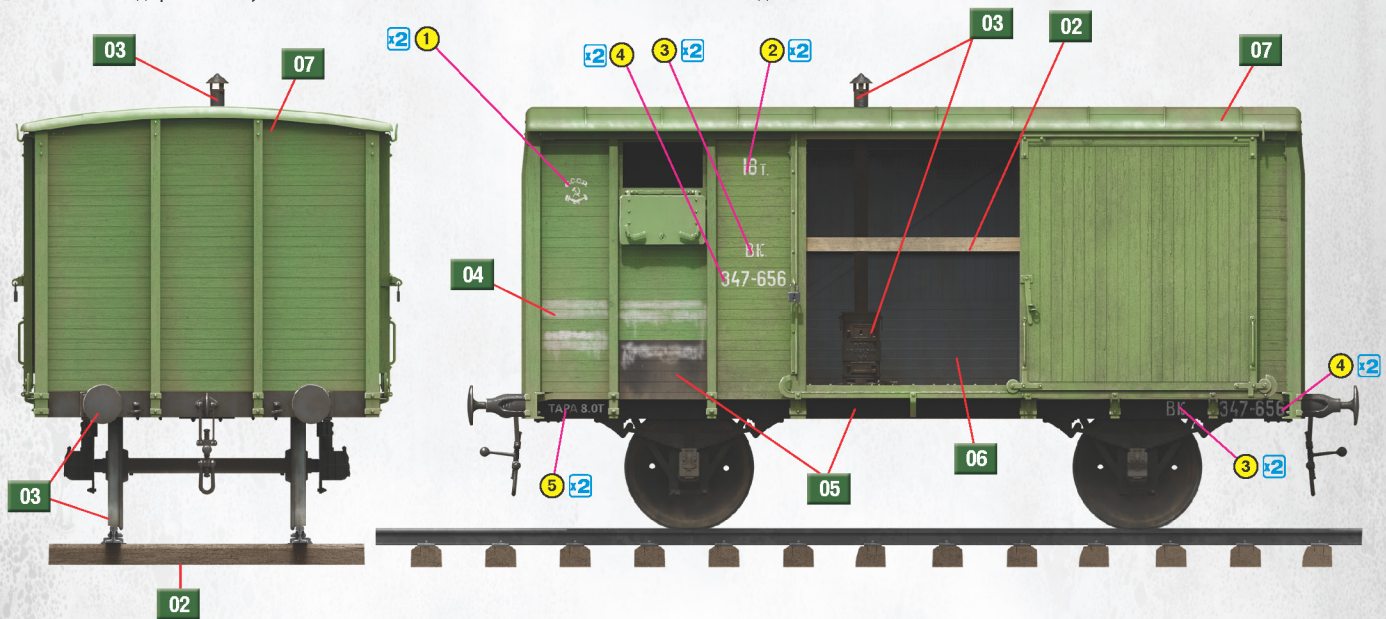

- 2** **Orenburg Railroad. Railway carriage as a part of a military train, 1943.**
Оренбургская железная дорога. Вагон в составе воинского эшелона, 1943 год.

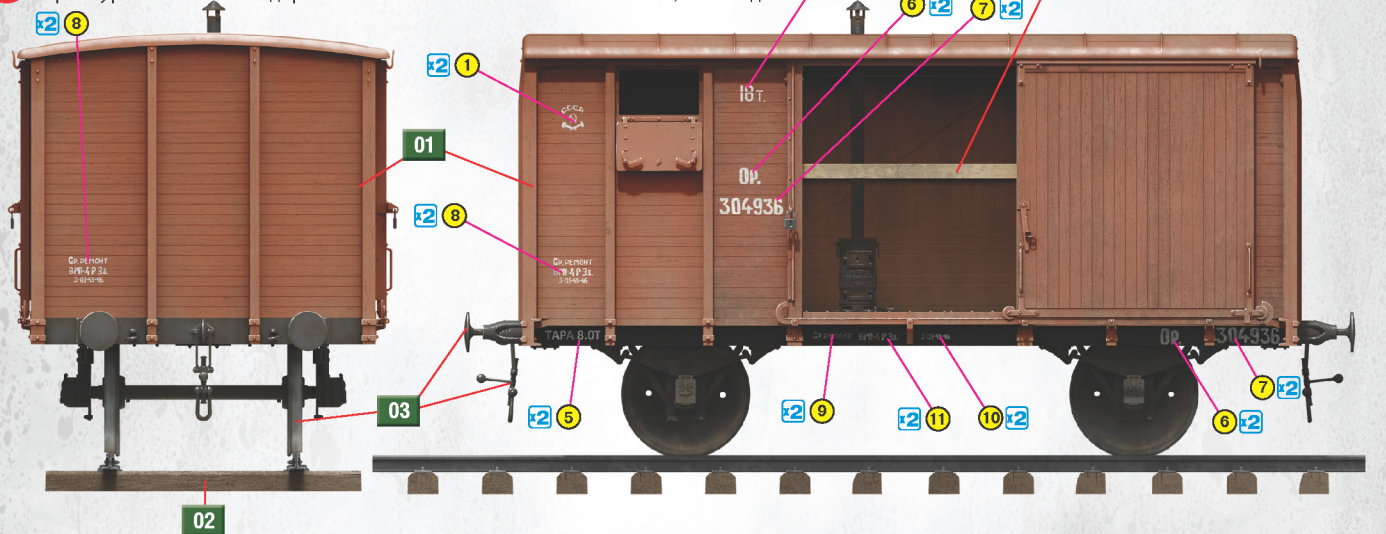

- 3** **Deutsche Reichsbahn (imperial railway administration), occupied territory of the Soviet Union, 1942-1944.**
Deutsche Reichsbahn (имперское управление железных дорог), на оккупированной территории Советского Союза, 1942-1944 годы.

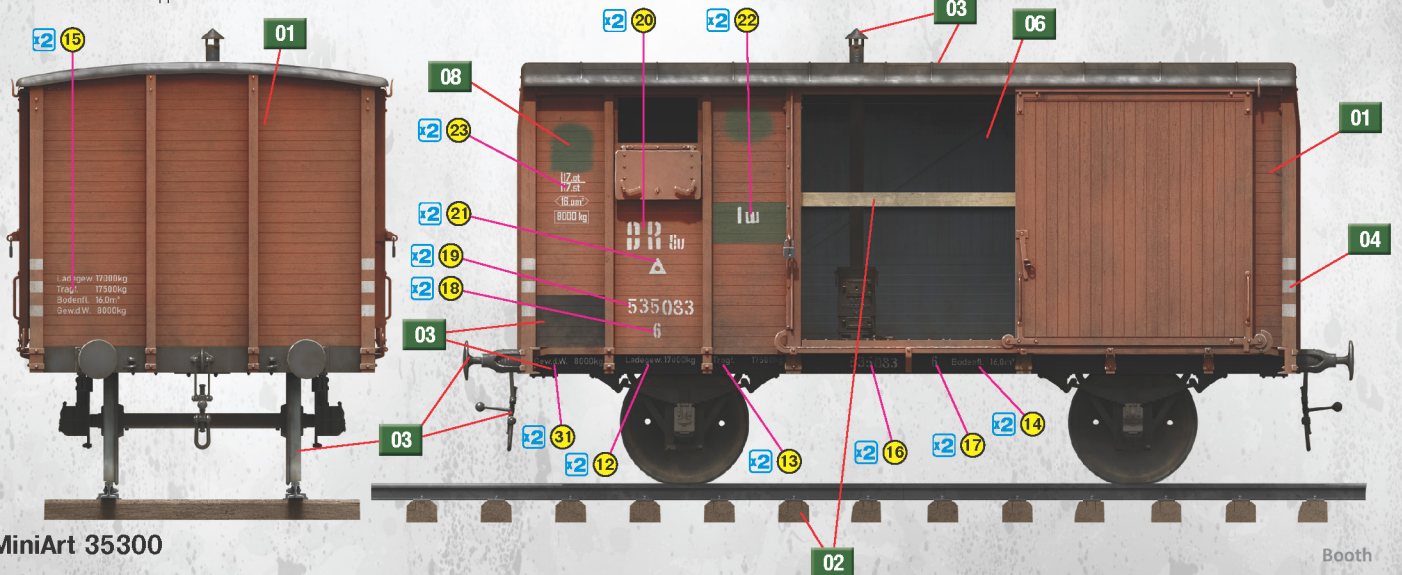

ATTENTION

Ne pas utiliser de colle ou de peinture à proximité d'une flamme nue, et aérer la pièce de temps en temps.
 Pour retirer les pièces hors du cadre, utiliser des ciseaux spéciaux pour maquette le plastique en excès avec un cutter ou une lime.
 Voir la fin de cette colonne pour la signification des symboles.
 Après l'assemblage peut rester des pièces inutilisées.

ZUR BEACHTUNG

Kleber und Farbe nicht nahe von offenem Feuer verwenden und das Fenster von Zeit zu Zeit zur Belüftung öffnen.
 Zum Abschneiden der Teile vom Verbundstück eine Modellerschere verwenden und die überstehenden Plastikteile mit einem Messer oder einer Feile beseitigen.
 Die Bedeutung der Symbole finden Sie unten in dieser Spalte.
 Nach dem Zusammenbau des Modells, können einzelne Teile übrig bleiben.

УВАГА

При використанні клею та фарб всі роботи проводити подалі від джерел вогню у приміщенні, що добре провітрюється.
 Деталі відкремлювати від літників ножом або іншим ріжучим інструментом. Зачистити облой і місця зрізу за допомогою надфілю та наждачної паперу. Будівництво моделі виконувати згідно зі схемою. Для зручності побудови кожна деталь позначена номером.
 Після складання можуть залишитися невикористані деталі.

ATTENZIONE

Non usare colla a vernice vicino a fiamme esposte, e aprire le finestre di tanto in tanto per cambiare l'aria. Quando si staccano parti del carrello, usare forbici da modellismo e eliminare la plastica in eccesso con un coltello o una lima. Vedere in fondo a questa colonna per il significato.
 Dopo l'assemblaggio possono rimanere parti inutilizzate.

ВНИМАНИЕ

При использовании клея и красок все работы производить в проветриваемом помещении вдали от источников огня.
 Детали отделять от литников ножом или другим режущим инструментом. Зачистить облой и места среза при помощи надфиля и наждачной бумаги. Сборку моделей производить согласно схеме сборки.
 Для удобства сборки каждая деталь обозначена номером.
 После сборки набора могут остаться неиспользованные детали.

CAUTION

When you use glue or paint, do not use near open flame, and use in well ventilated room. When you take parts off from the runner frame, use modeling scissors or cutter.
 See the bottom of this column for the meaning of symbols.
 Extra details can remain after assembling of the kit.

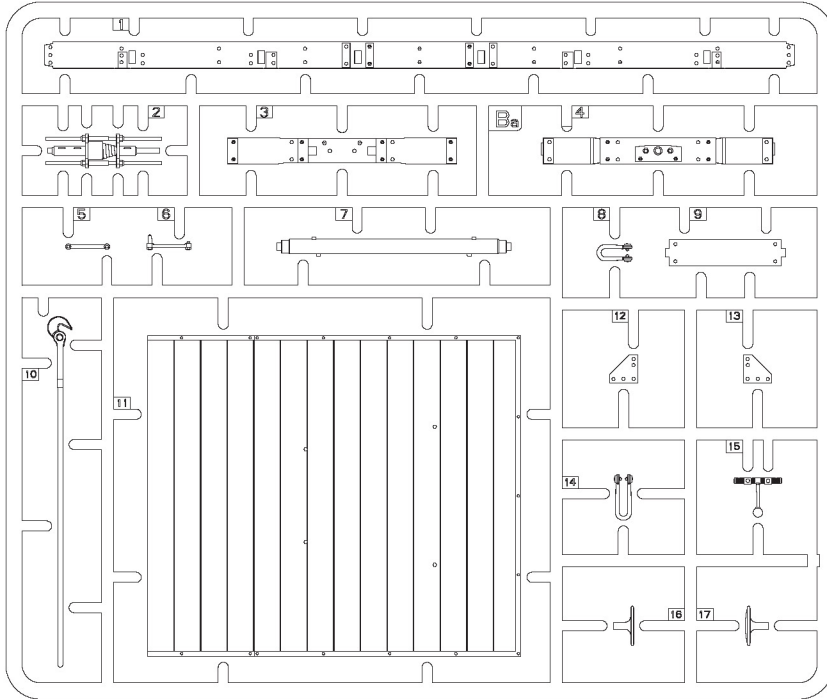
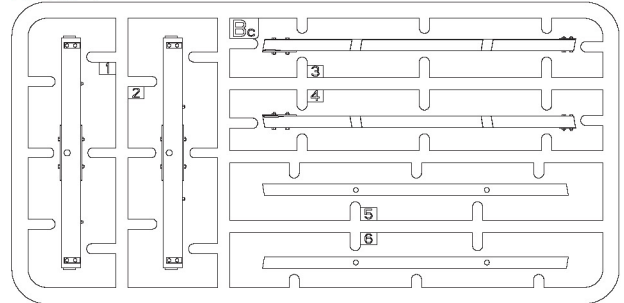
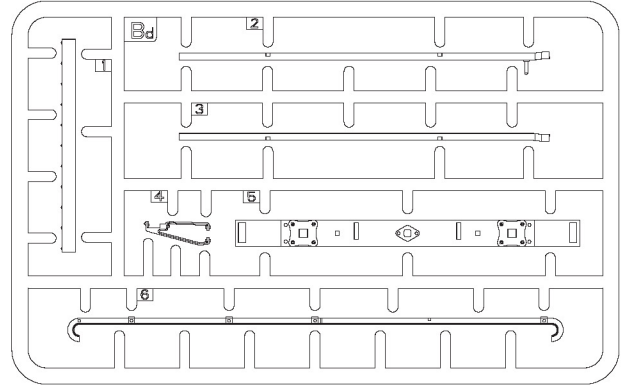
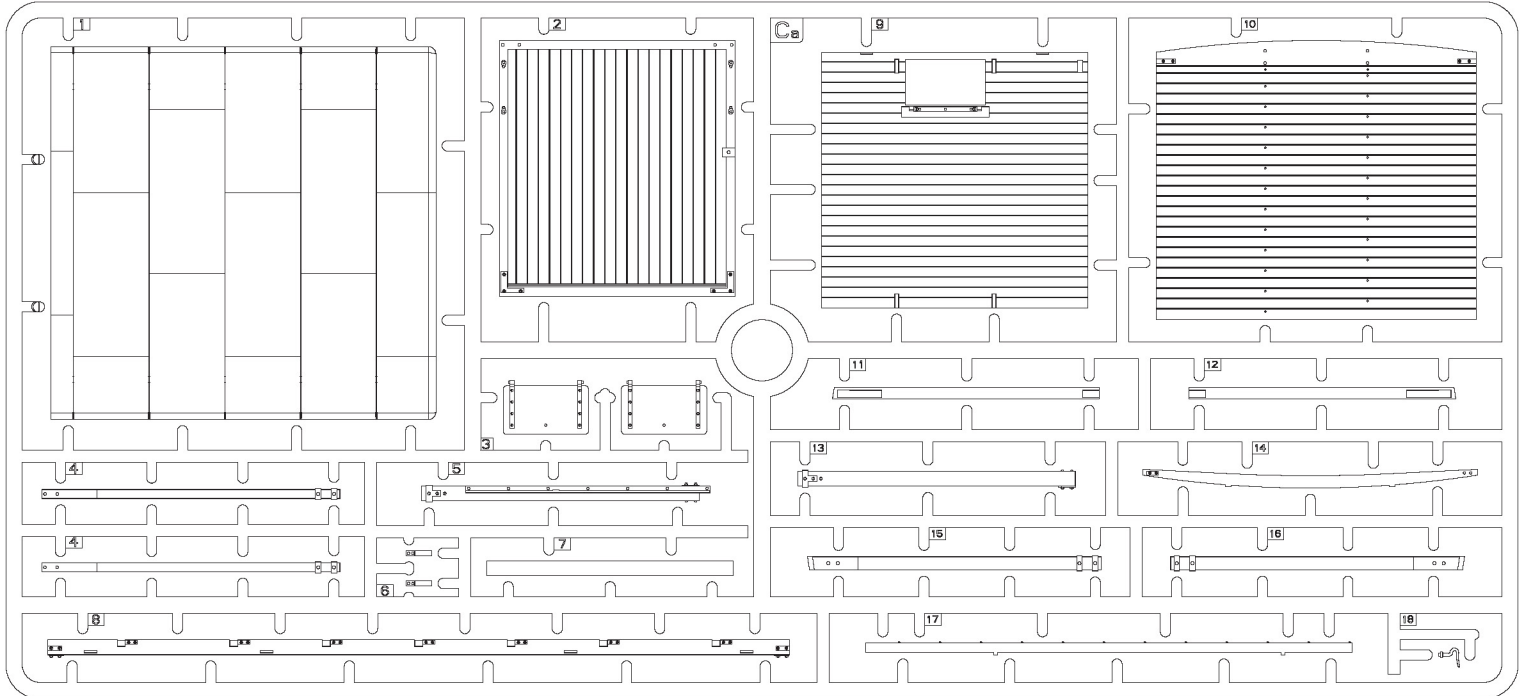
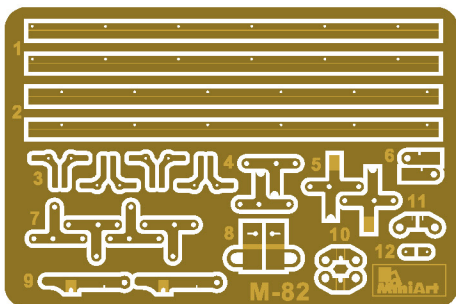
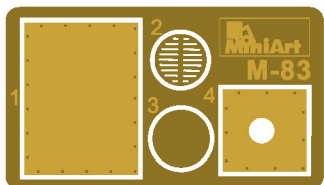
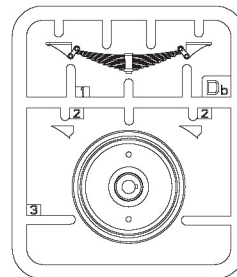
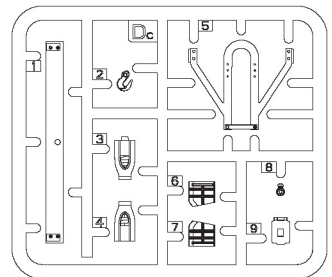
PARTS**Ba x2****Bc x2****Bd x2****Ca x2****Photo-etched parts PEa****PEb****Db x4****Dc x4**



MAKE 2PCS
2 TEILE FERTIGEN
EFFECTUER 2 PIECES
FARE DUE PEZZI
TEE 2 KPL
GÖR 2 ST
ПОВТОРИТЬ ДВА РАЗА
КЛІКІТЬСЯ РАЗІВ



DO NOT CEMENT
NICHT KLEBEN
NE PAS COLLER
NON INCOLLARE
EILIMÄÄ
LIMÄÄ
НЕ ИСПОЛЬЗОВАТЬ КЛЕЙ
НЕ КЛІЄТИ



OPTIONAL
NACH BELIEBEN
FACULTATIVO
VALINNANVARAINEN
VALBAR
ВАРИАНТЫ



OPEN HOLE
OFFENEN
FAIRE UN TROU
FORO APERTO
AVAA REIKÄ
OPPIHA HALET
СДЕЛАТЬ ОТВЕРСТИЕ
ЗРОБИТИ ОТВІР



REMOVE
ENTFERNEN
RETIRARE
SEPARARE
POISTA
AVLAGSNA
OTREZATI
VİDRİZATI



BEND
BITTE BIEGEN
PLIER S'IL VOUS PLAİT
PIEGARE
TAIJA
BOCKA
ВЫГНУТЬ
ВИГНУТИ



SCRATCHBUILD
AM MEISTEN ZU MACHEN
FAIRE LE PLUS
RENDITI
TEE ITSE
GÖR DIG SJÄLV
СДЕЛАТЬ САМОМУ
ЗРОБИТИ САМОМУ

PARTS

Ac x4

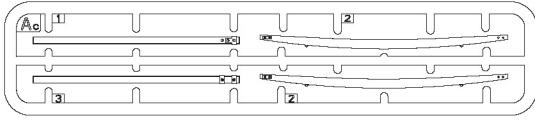

Aa x2

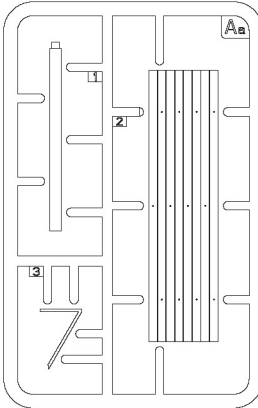

Ab x4

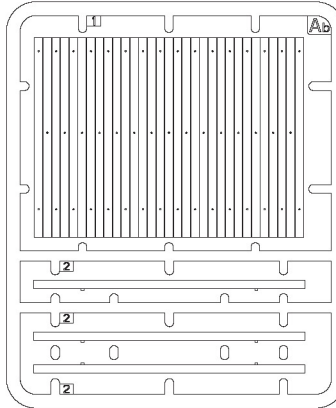

Df x2

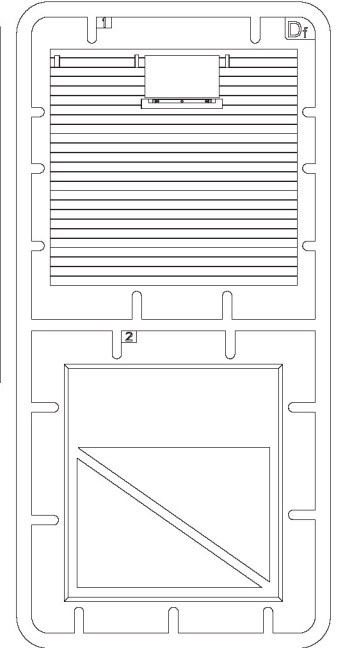

Gc

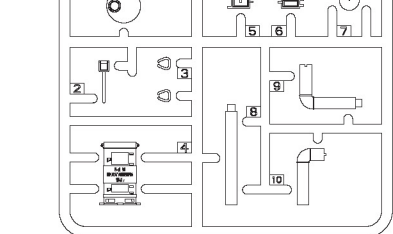

Ca x4 Parts of railroad track

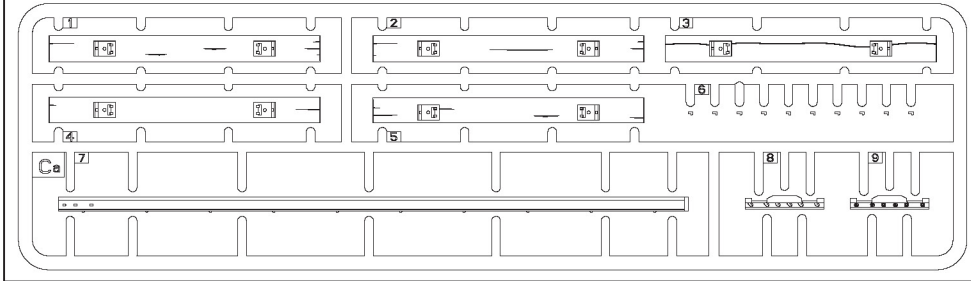

Dj x4

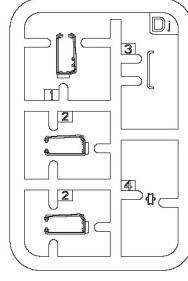

Posters

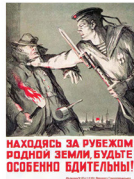

Decal

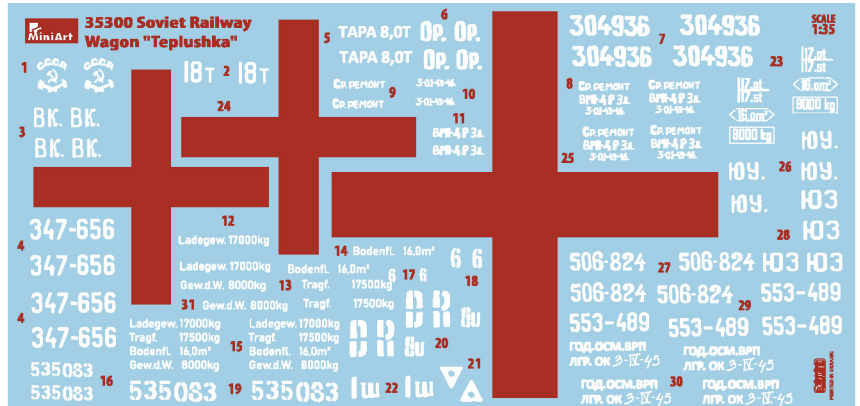

Мы отстаивали родимый край,
Героев Берлина страна, встречай!

МЫ ИЗ БЕРЛИНА!

Мы волю народа исполнили свято.
Теперь уйдем до дому, до хаты.



Наше дело правое - мы победили!



Мы из
Кёнигсберга

Долой,
на Родину!

1 x2

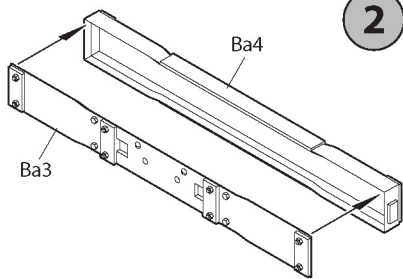

2 x2

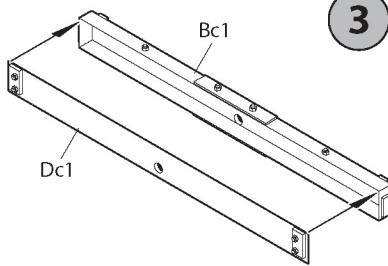

3 x2

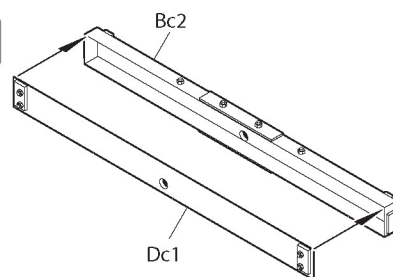

4 x2

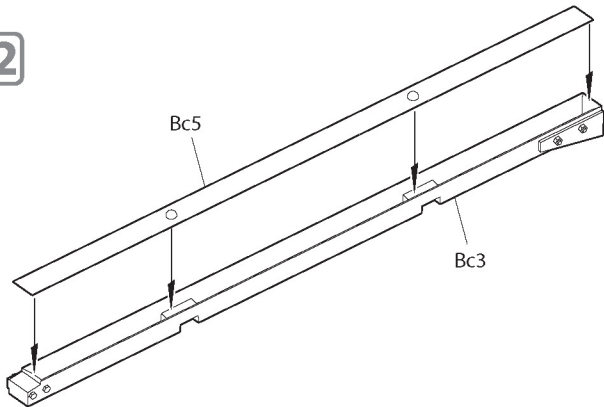

5 x2

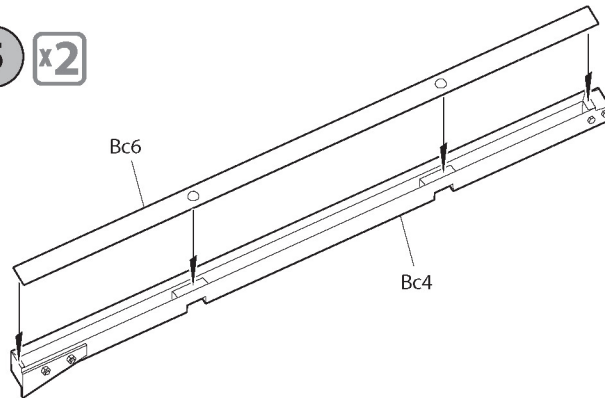

6

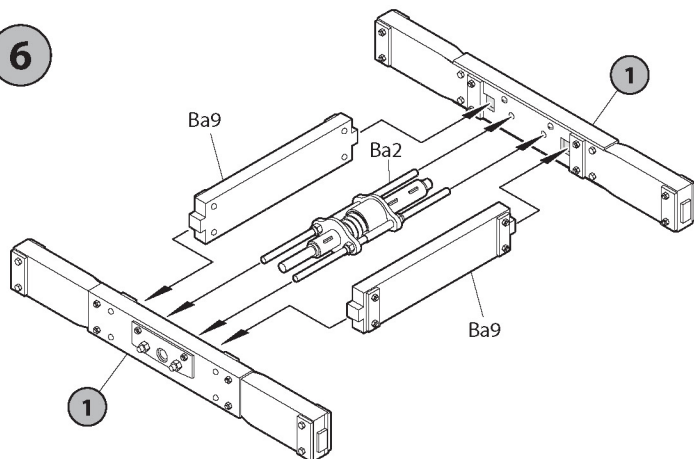

7 x4

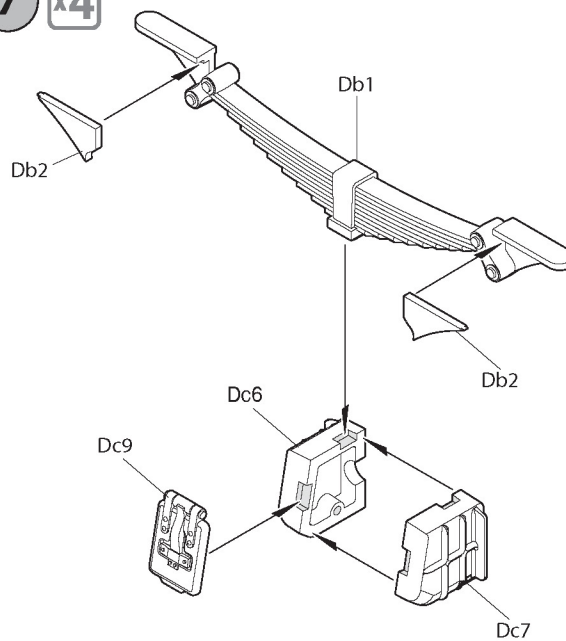

8 x2

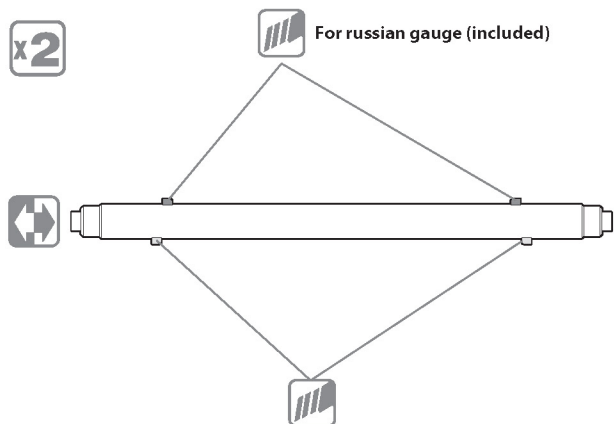

For russian gauge (included)

For european gauge, (Not included! Requires a set of 35561 RAILROAD TRACK. RUSSIAN GAUGE)

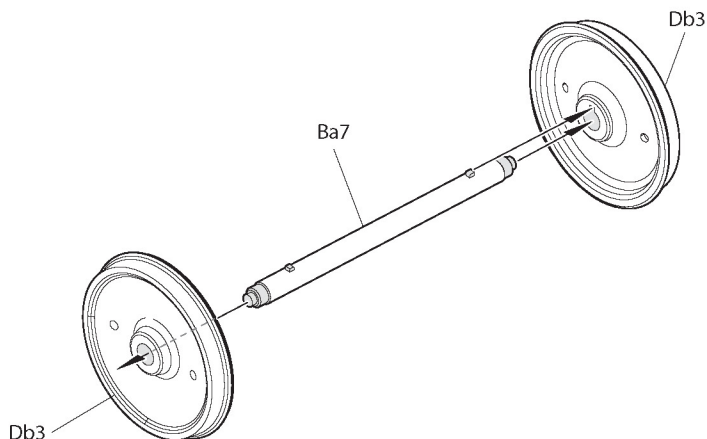

9

x2

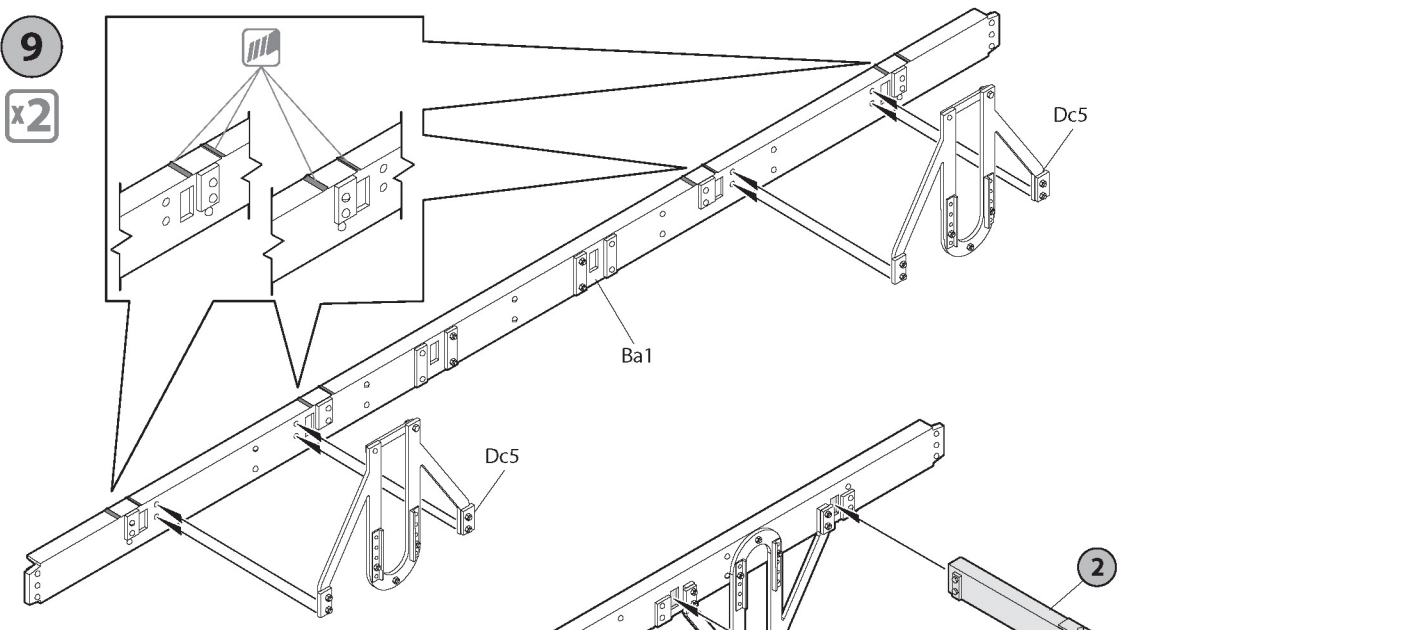

10

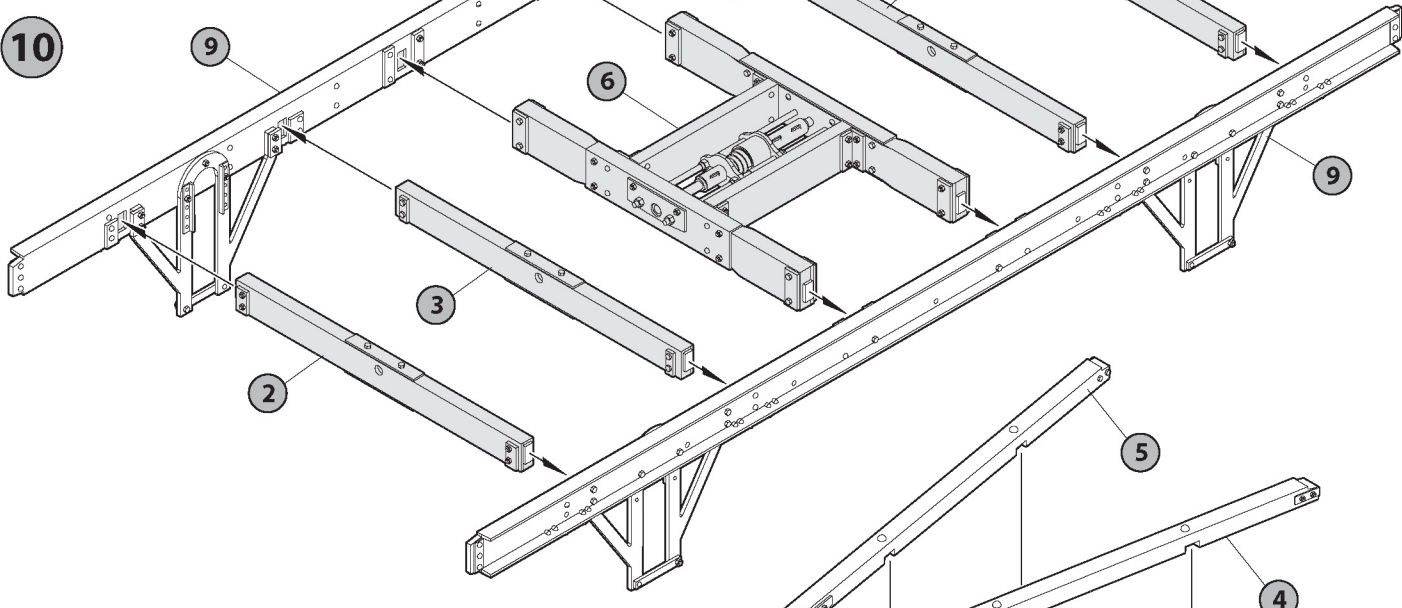

11

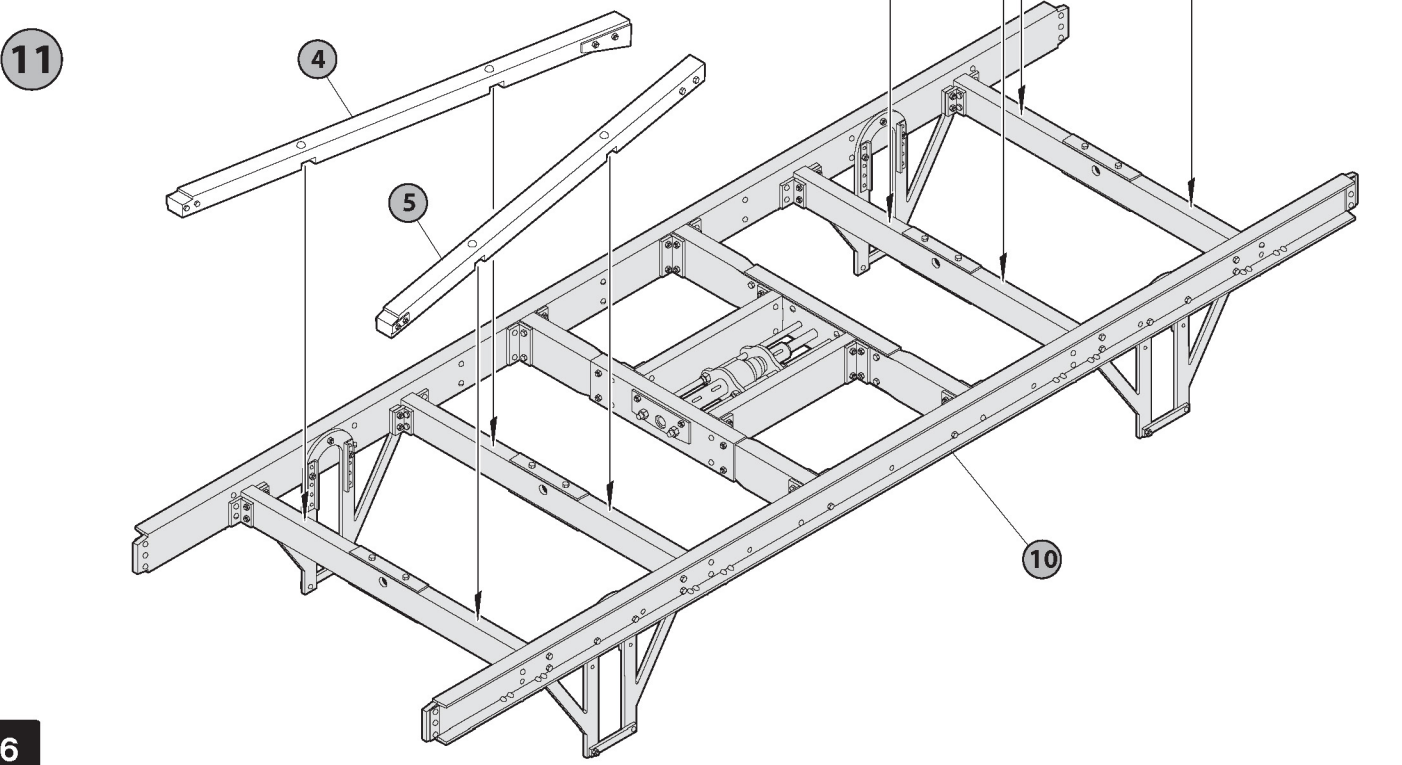

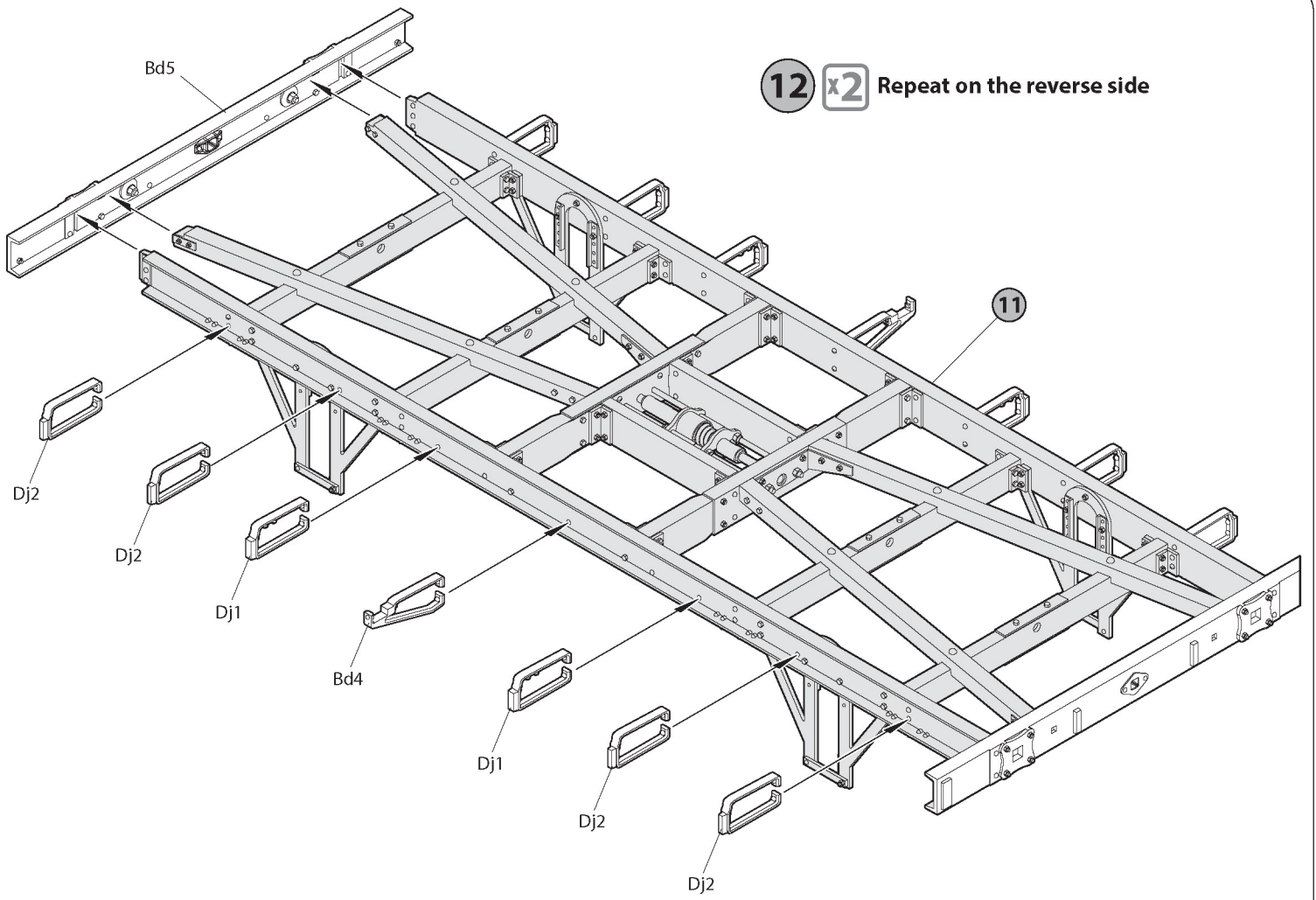

13 **x2** Repeat on the reverse side

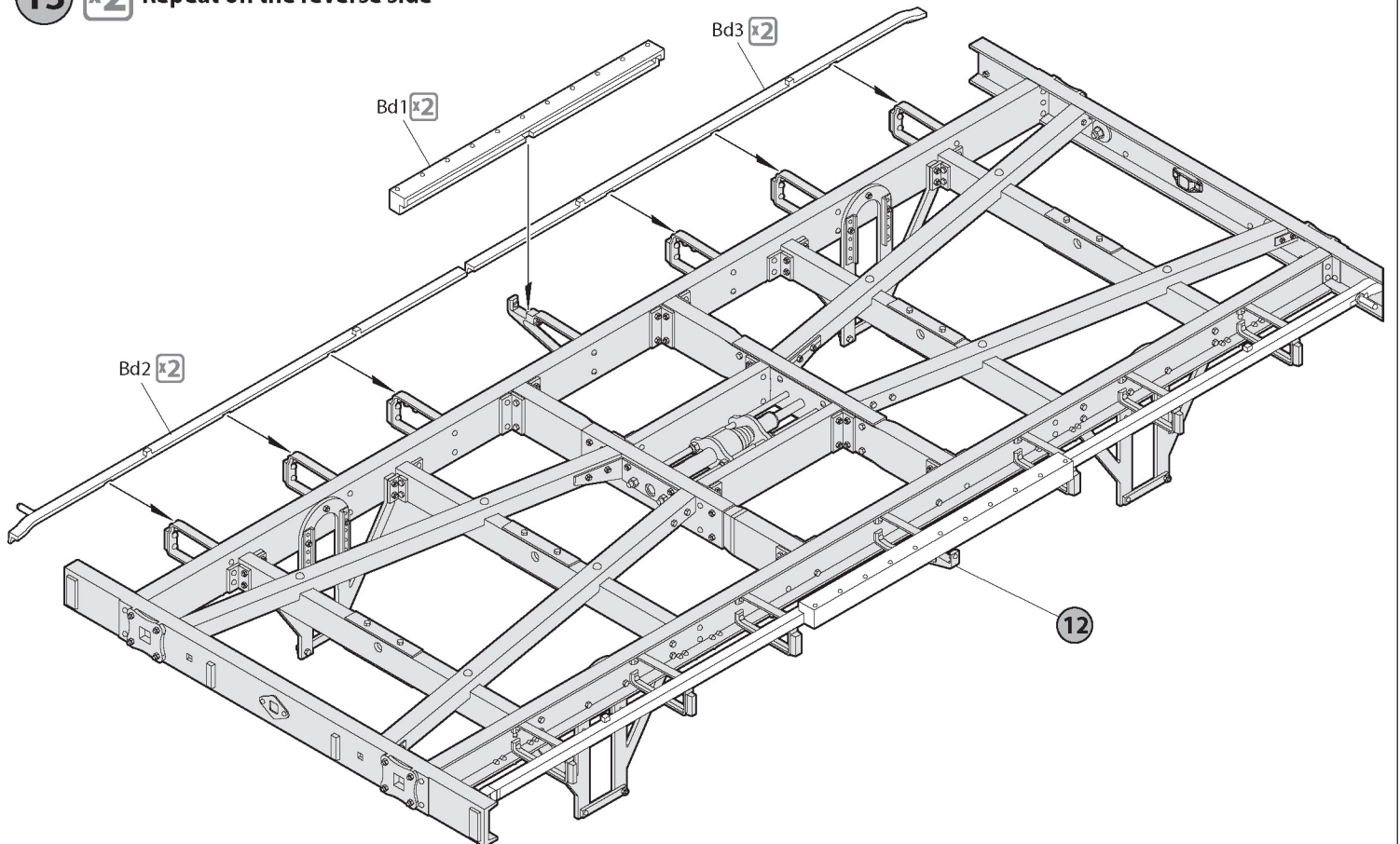

14 x2 Repeat on the reverse side

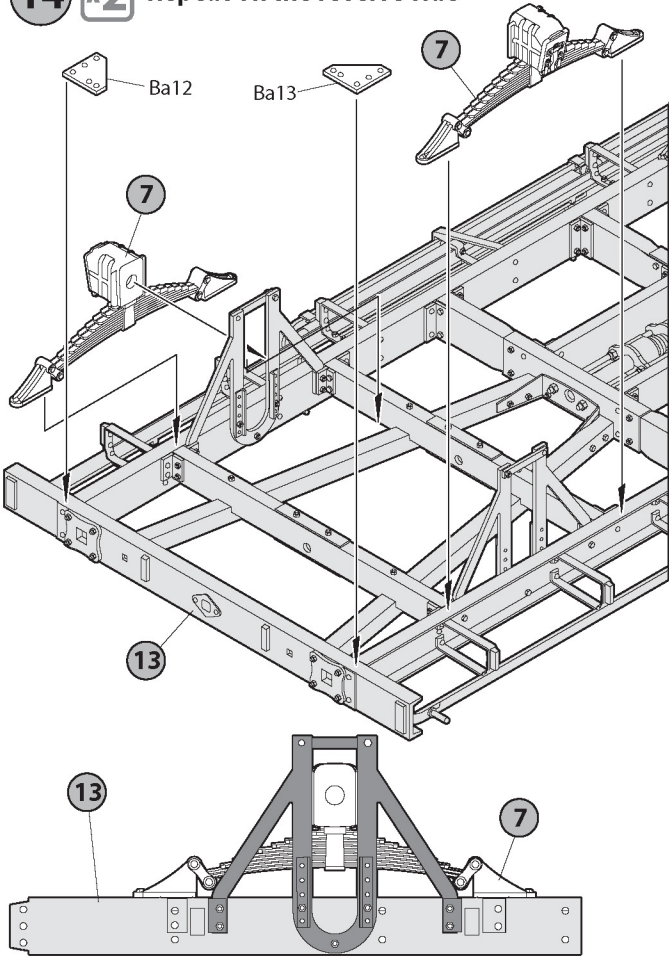

15 x2 Repeat on the reverse side

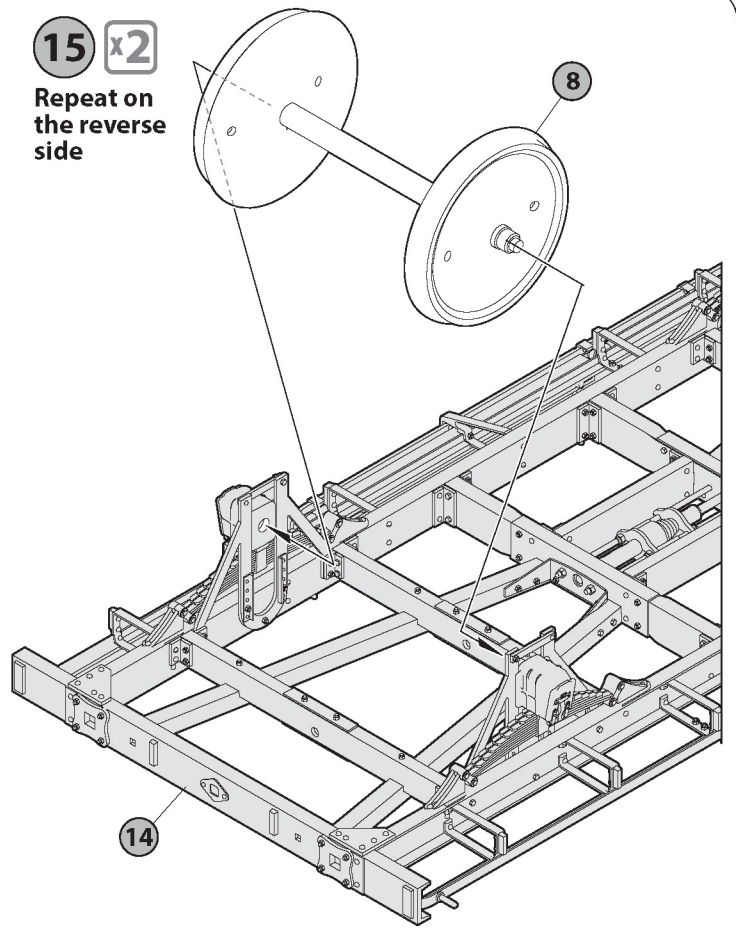

16 x2 Repeat on the reverse side

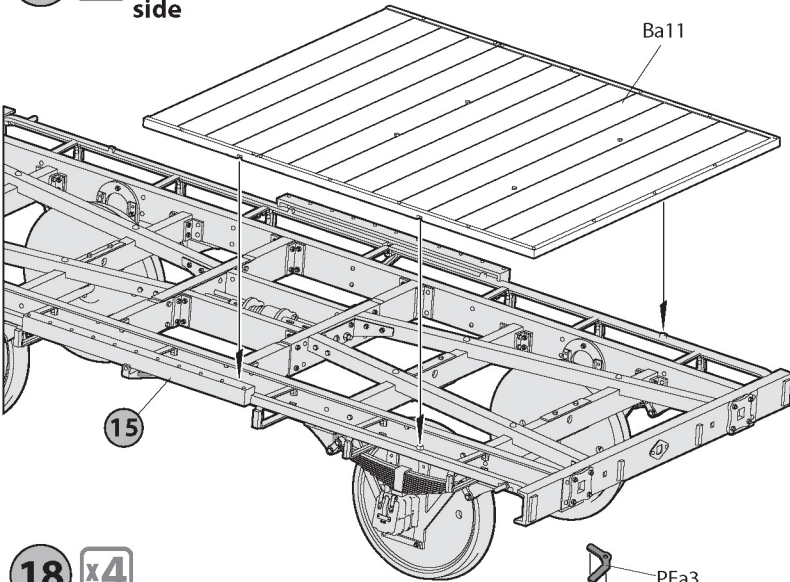

17 x2

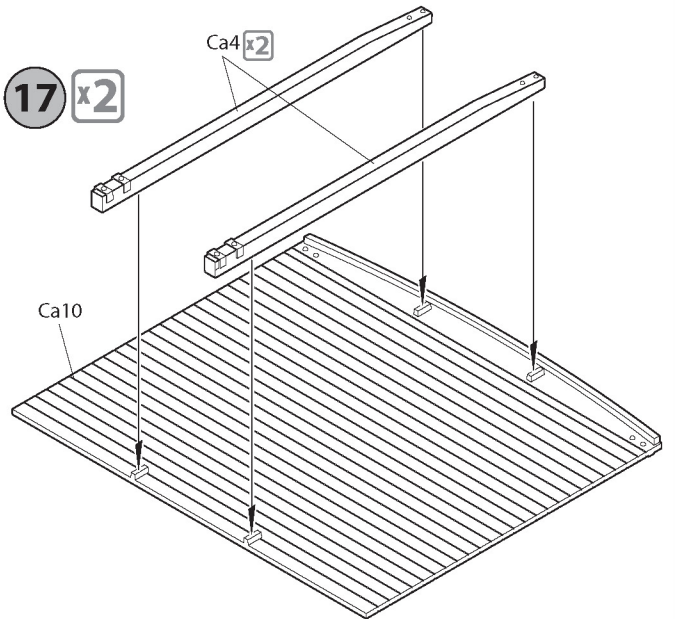

18 x4

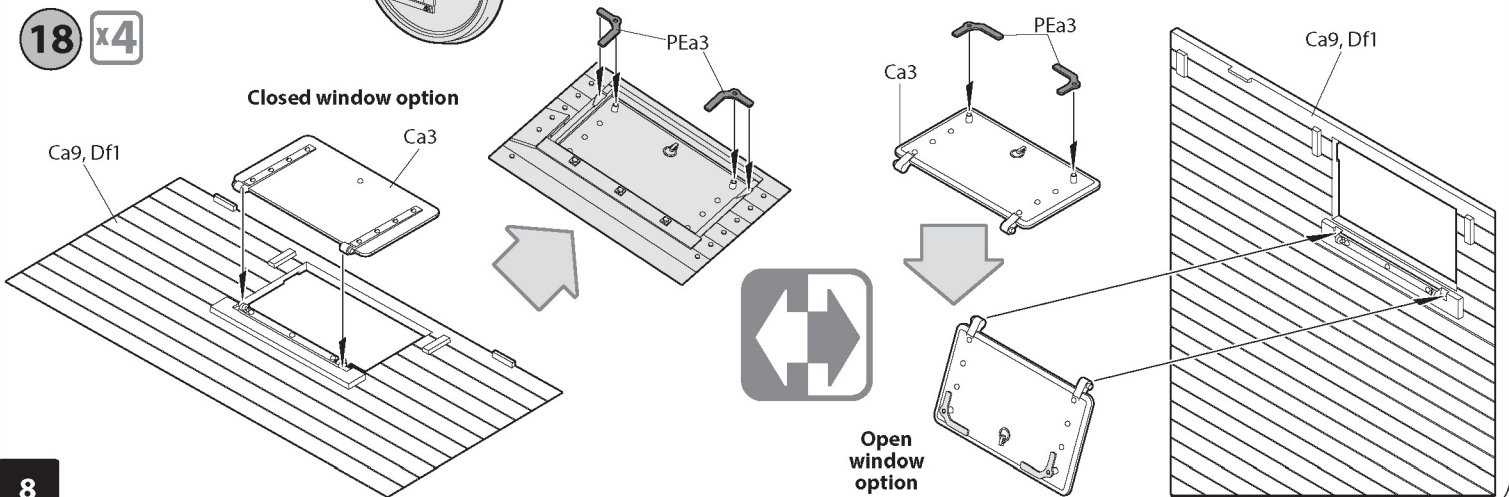

19 x2

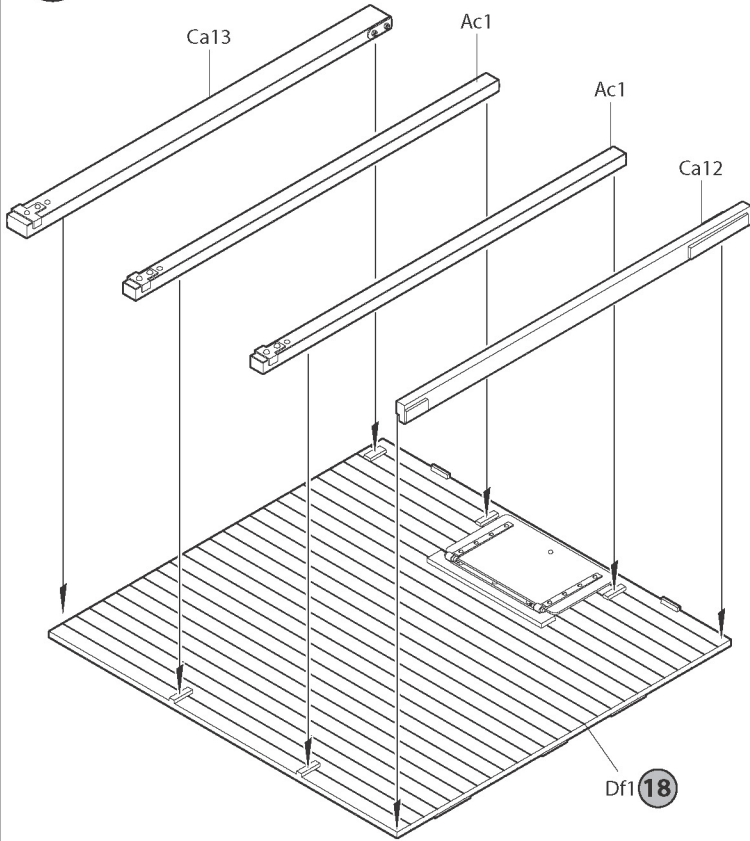

20 x2

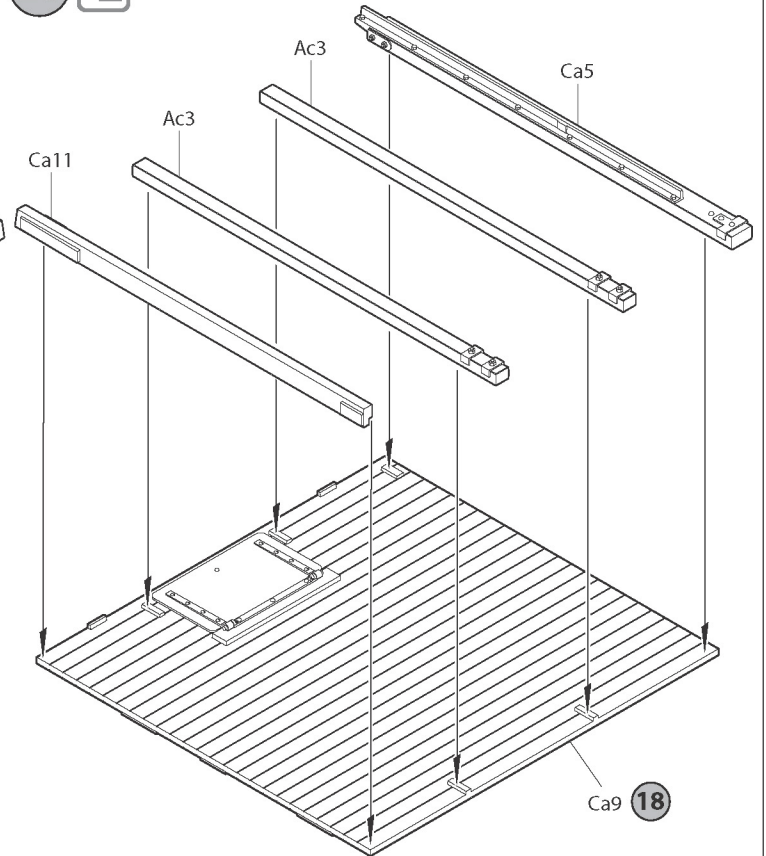

21 x2

Repeat on the reverse side
 Inside the car was painted
 in a reddish brown color.

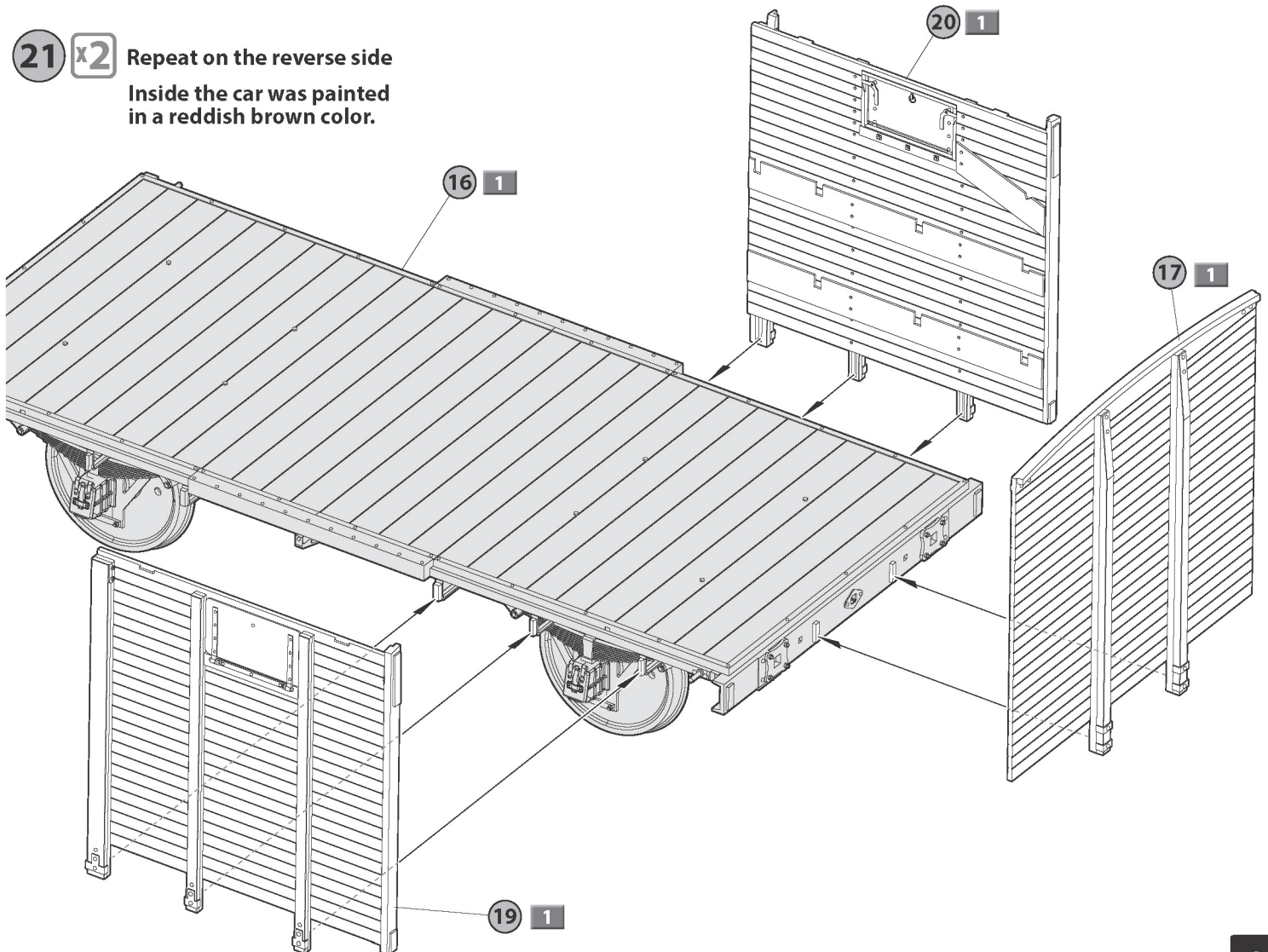

22 x2

Repeat on the reverse side

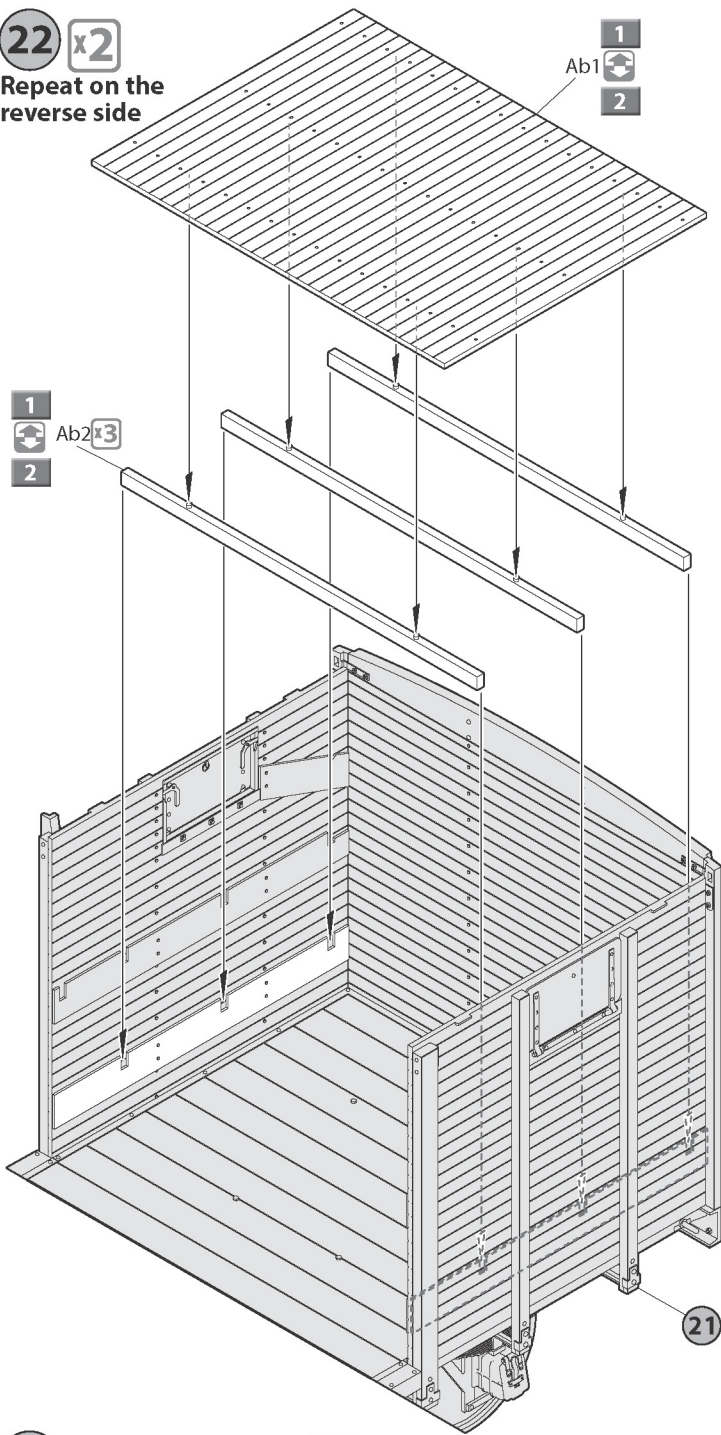

23 x2

Repeat on the reverse side

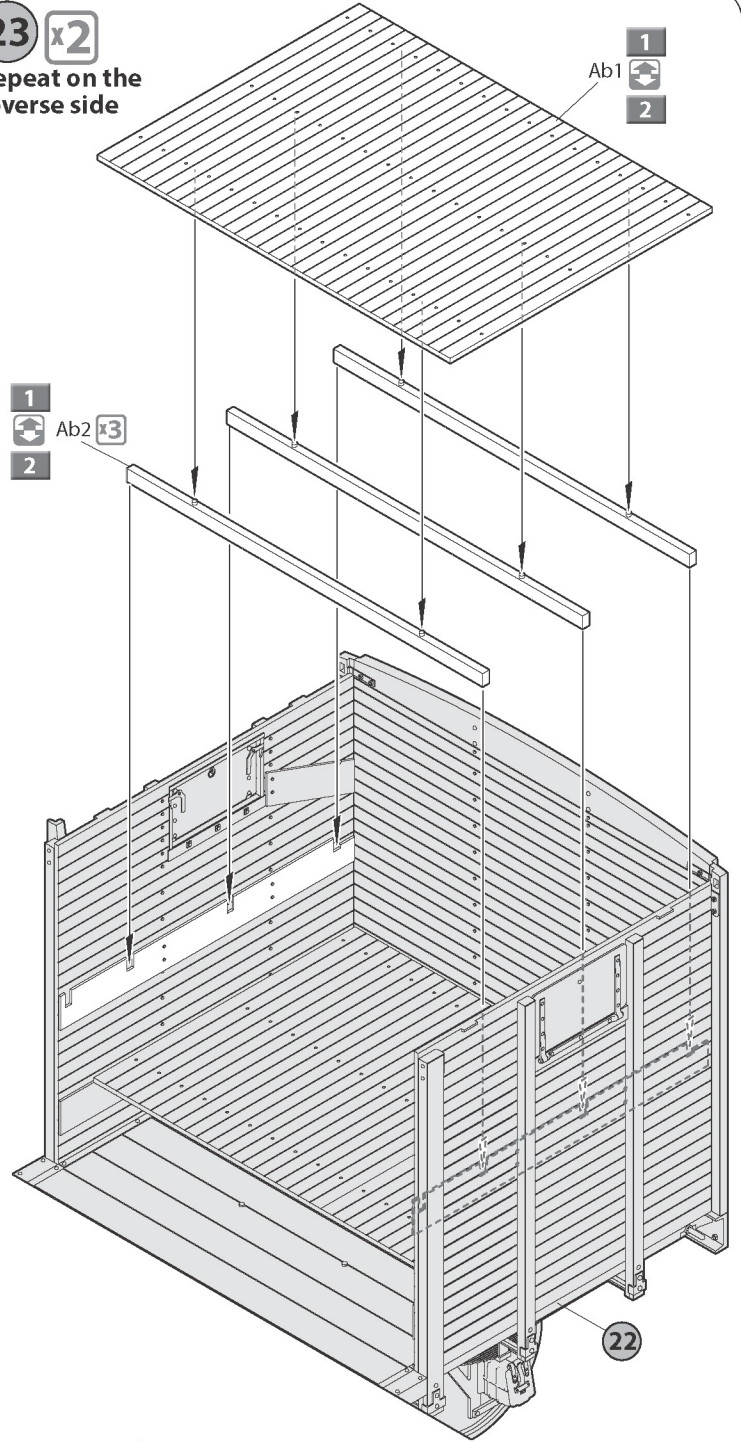

24 x2

Repeat on the reverse side

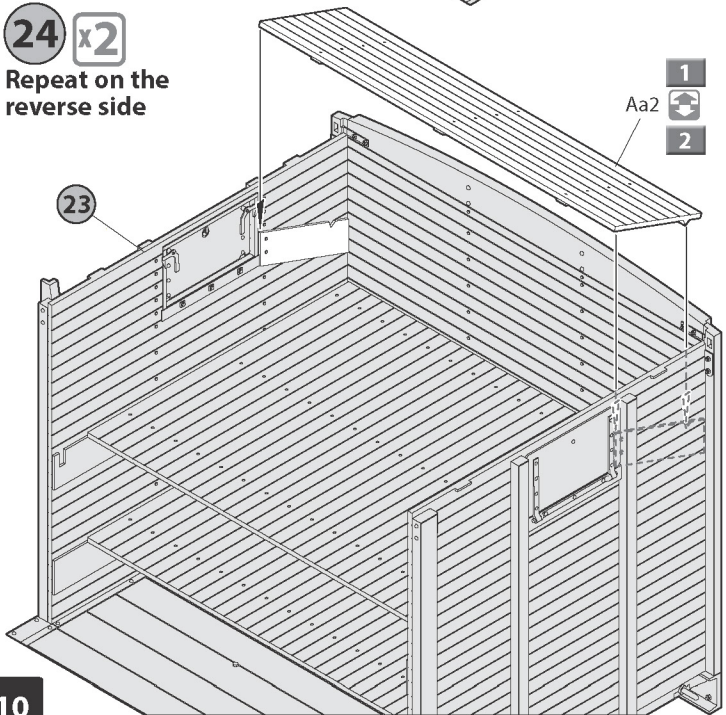

25

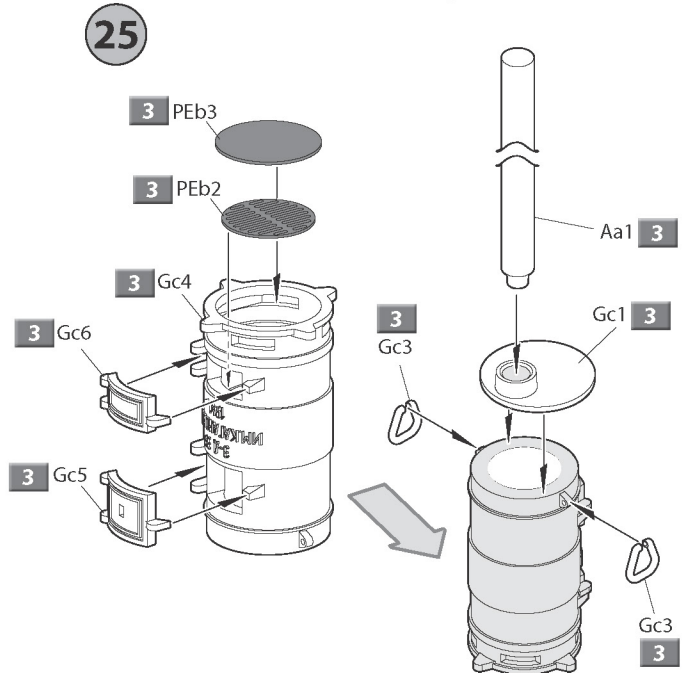

26 **x2** Repeat on the reverse side

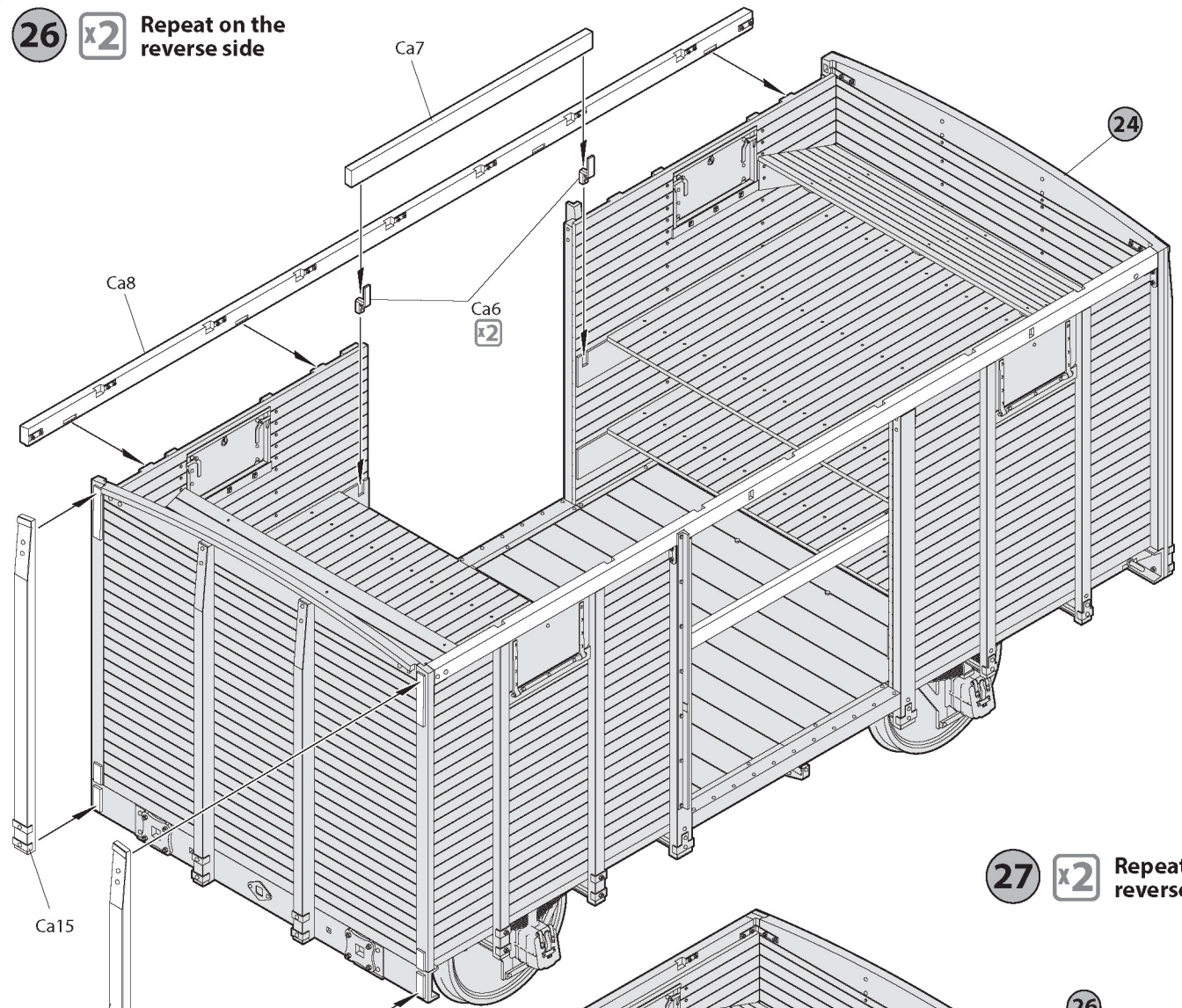

27 **x2** Repeat on the reverse side

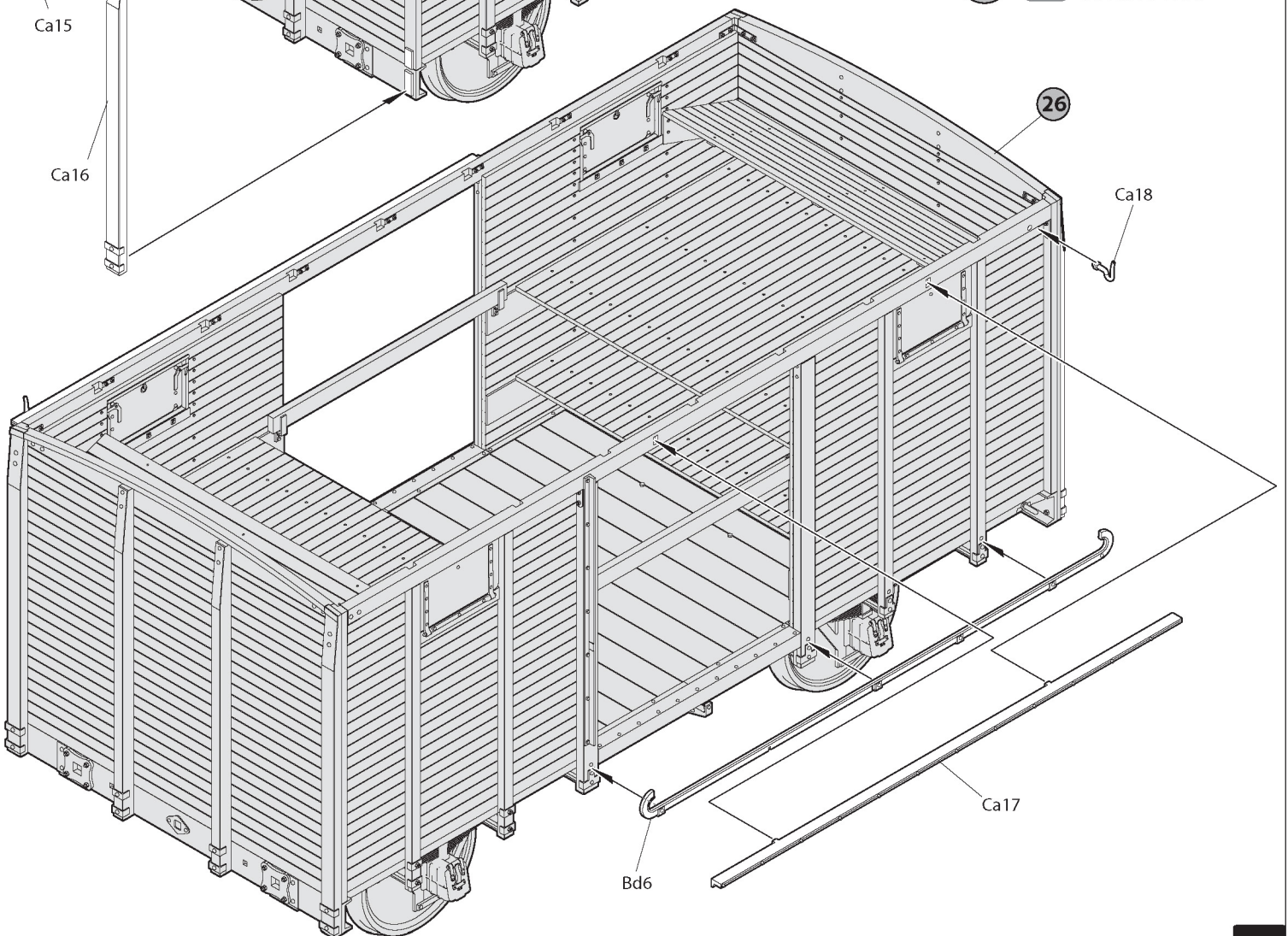

28

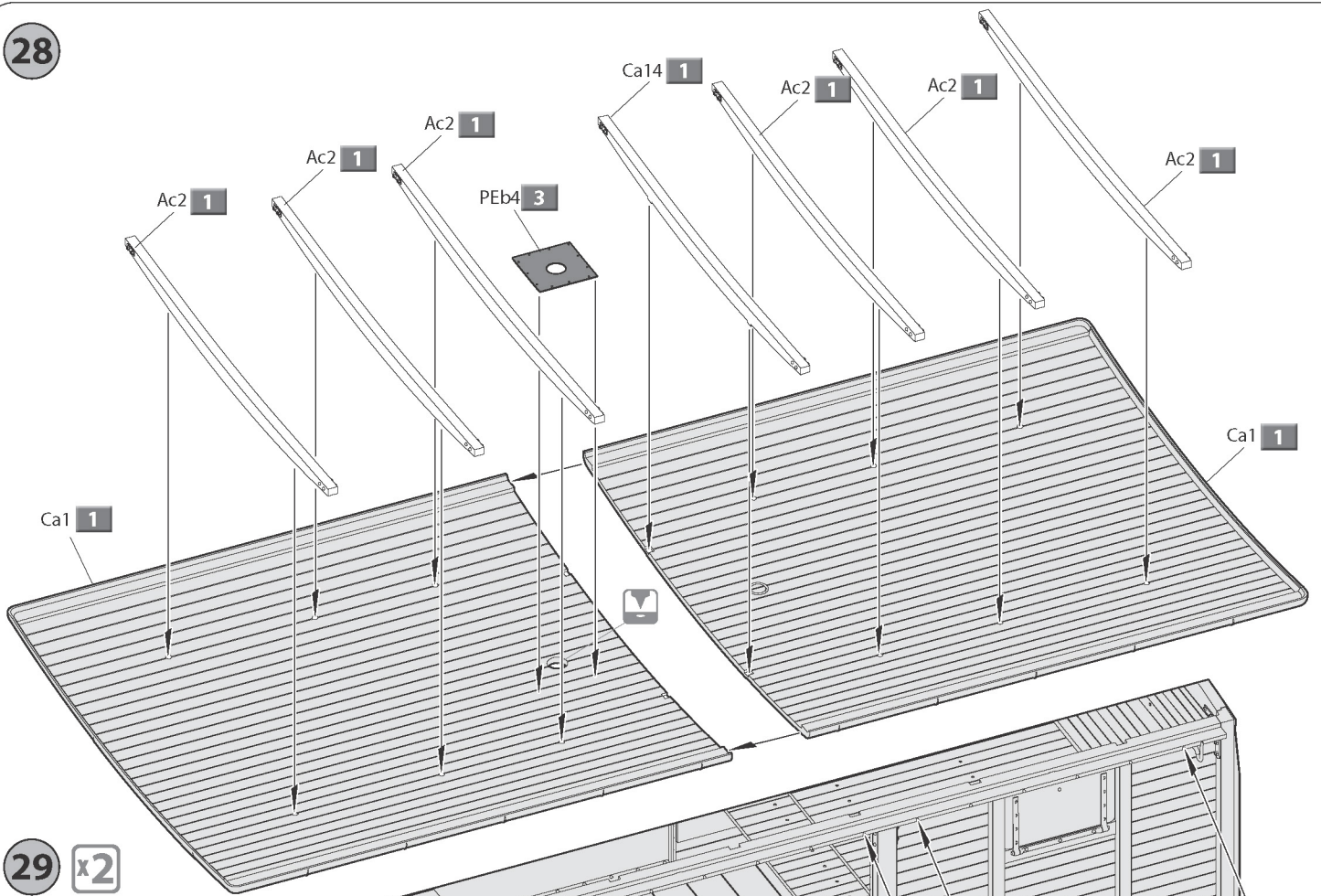

29 x2

Repeat on the reverse side

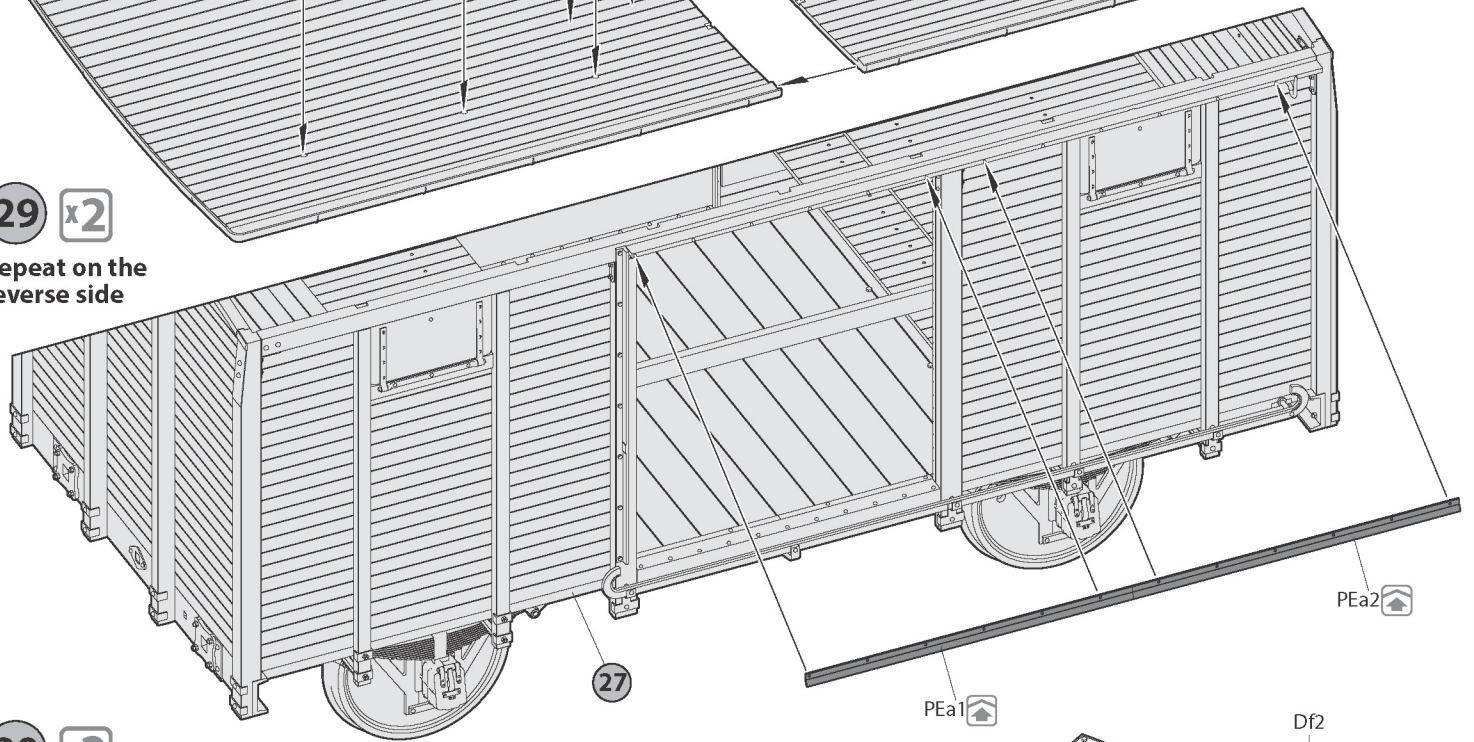

30 x2

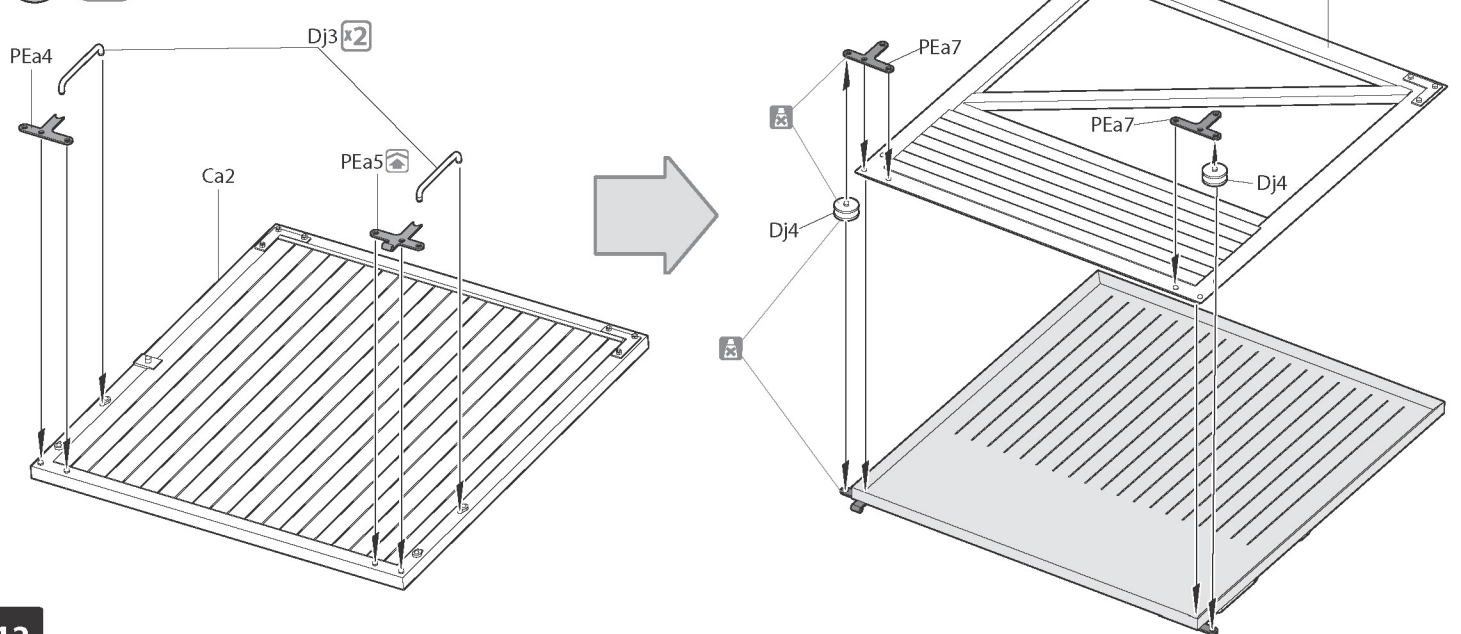

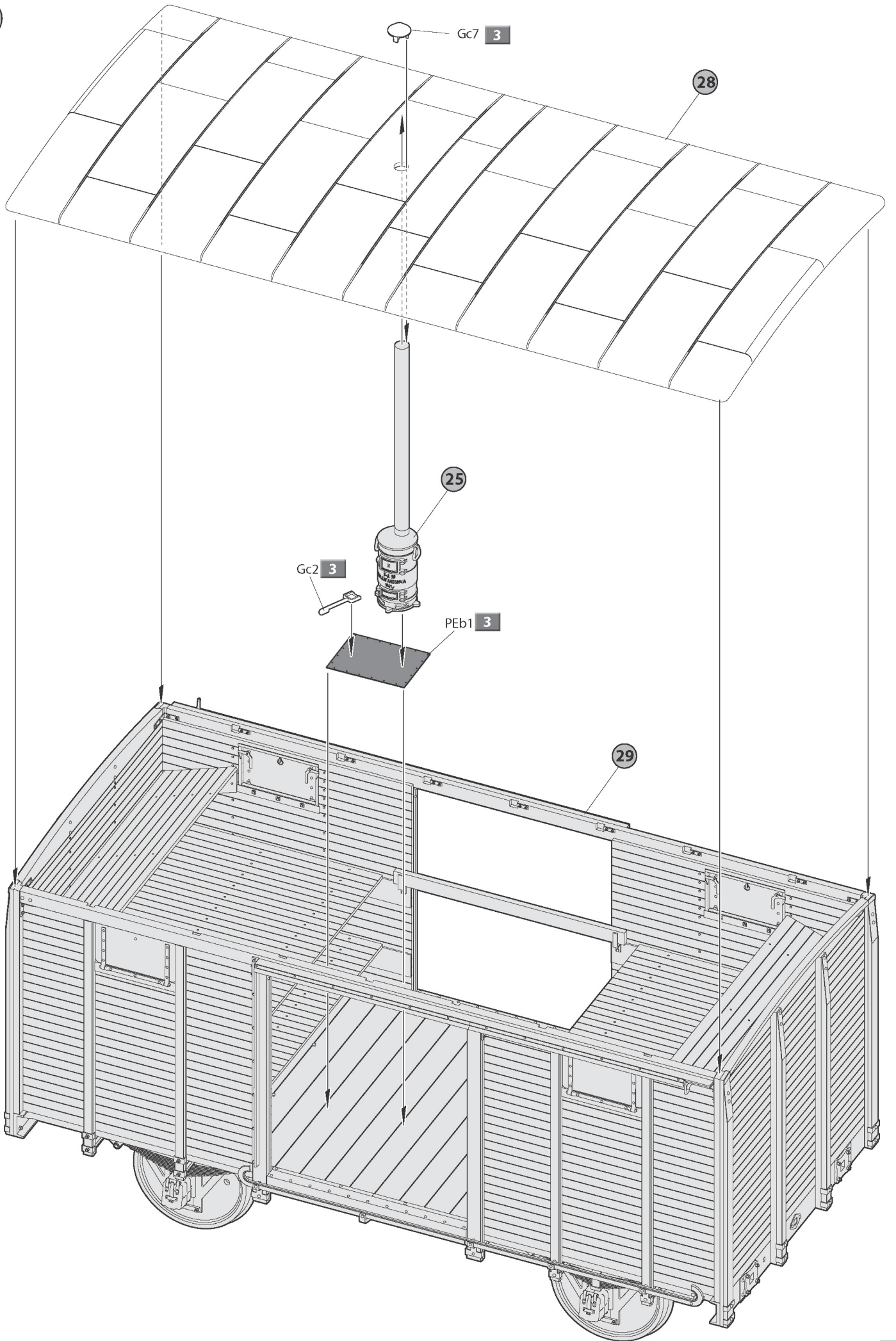

32 **x2** Repeat on the reverse side

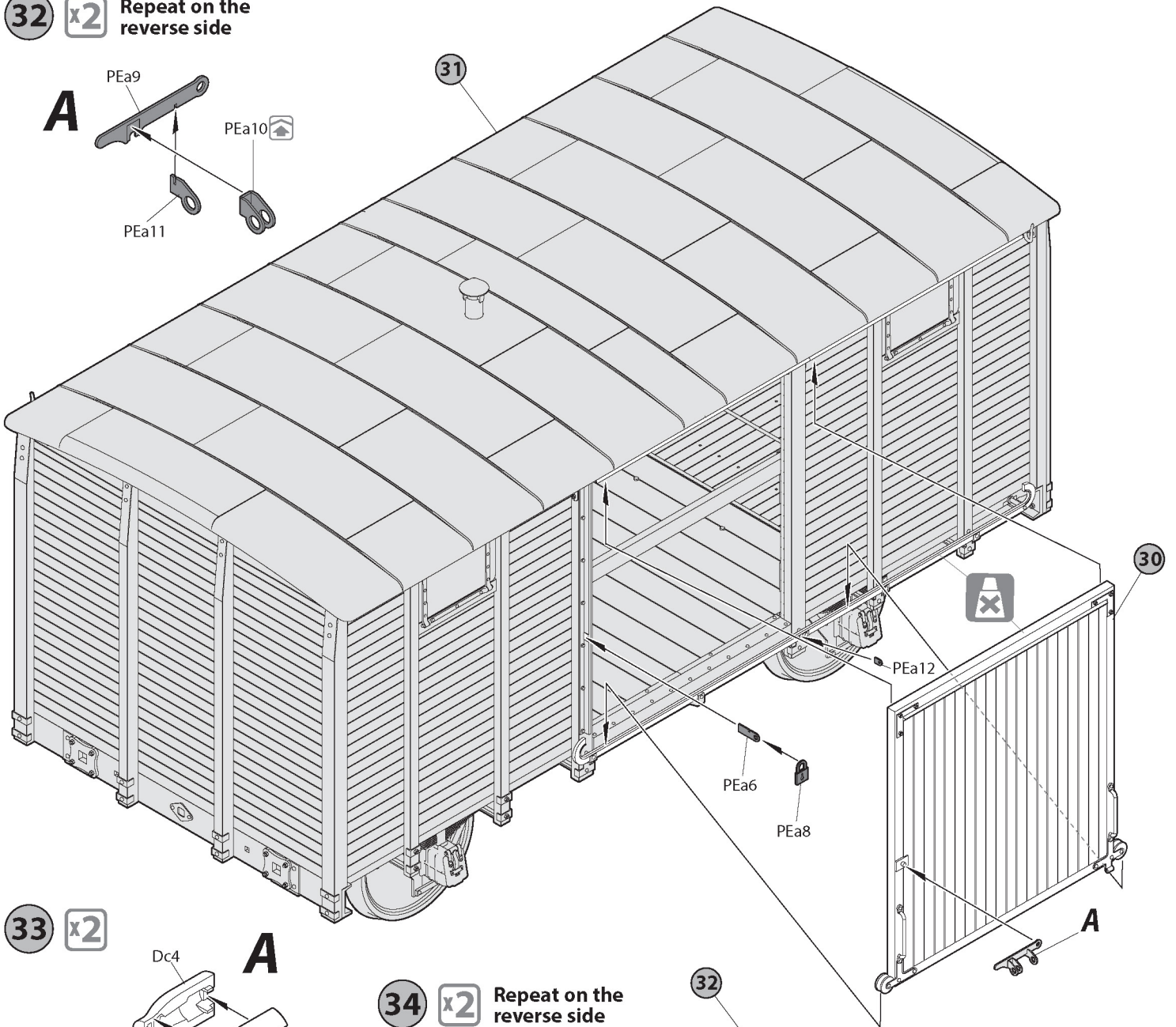

33 **x2**

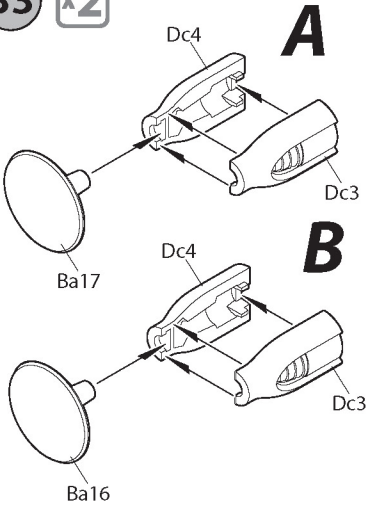

34 **x2** Repeat on the reverse side

32

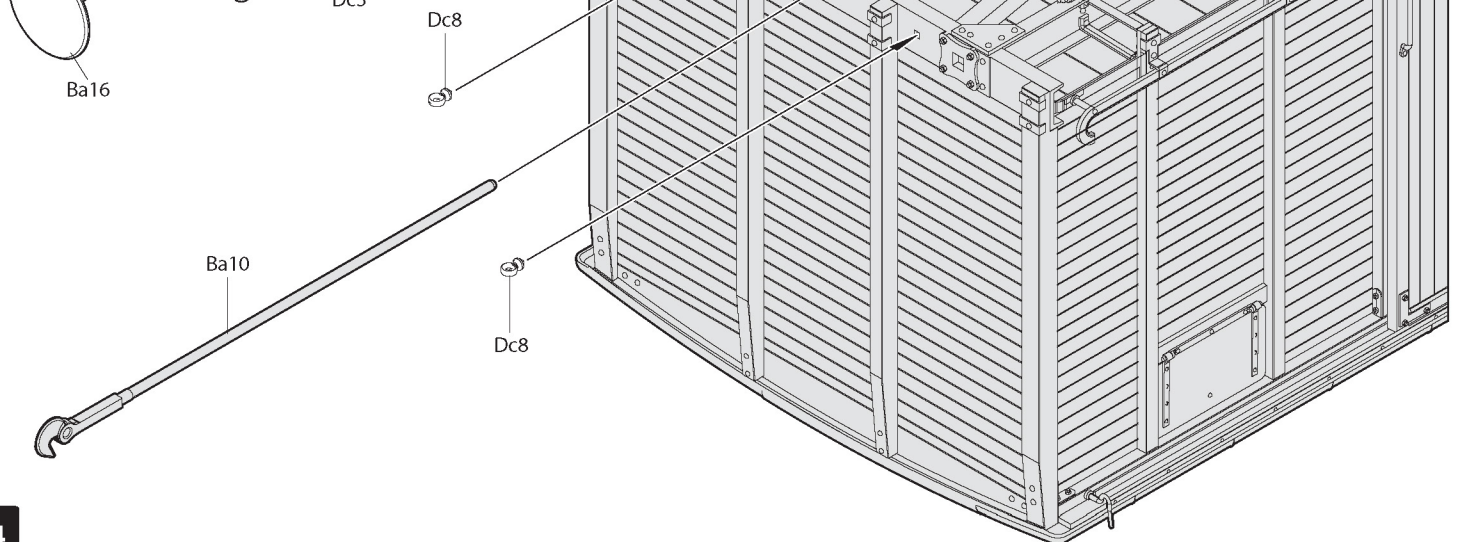

35 x2 Repeat on the reverse side

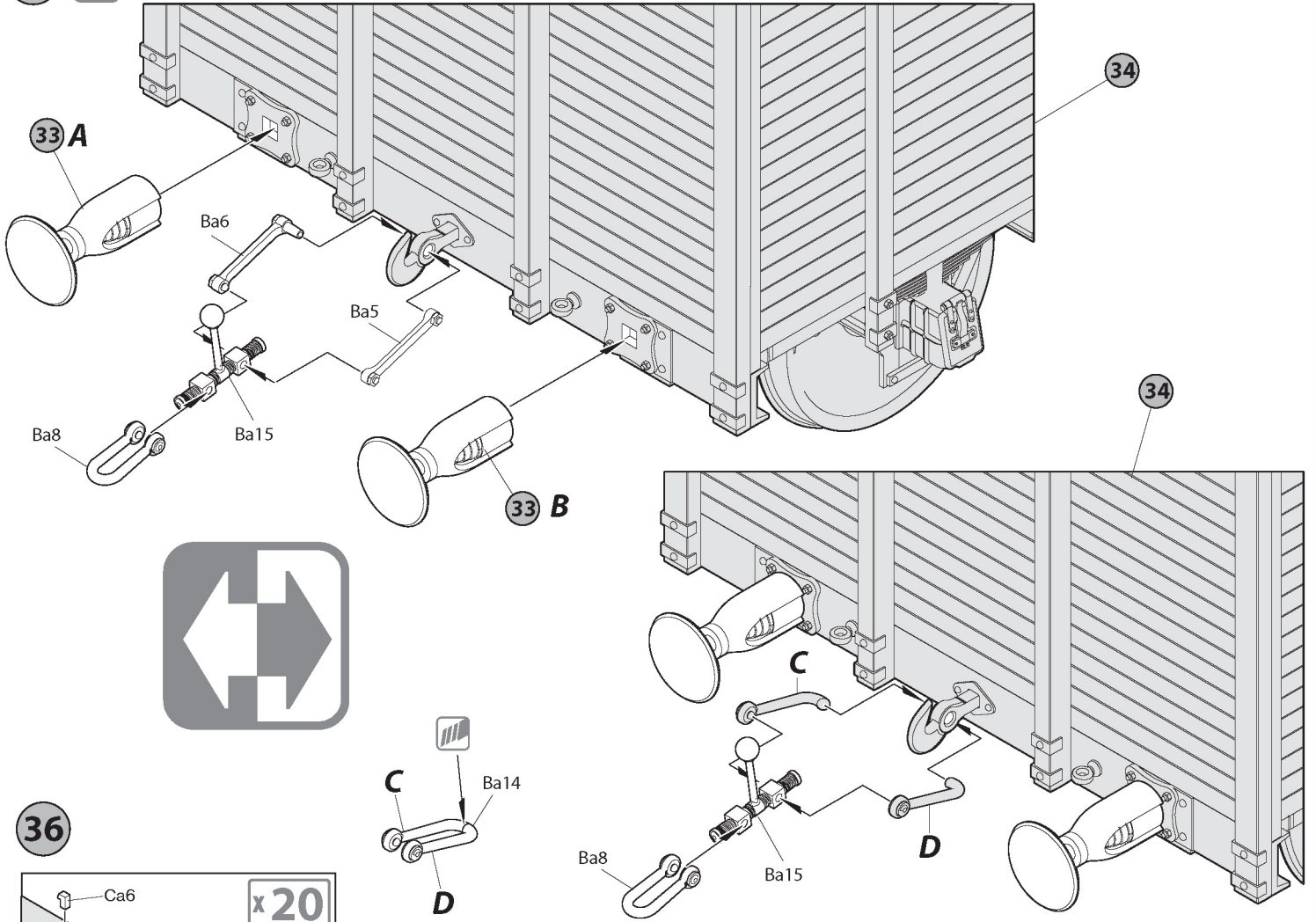

36

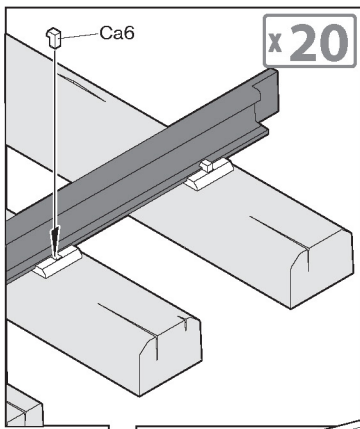

x20

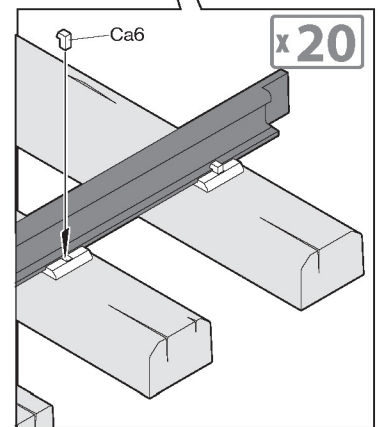
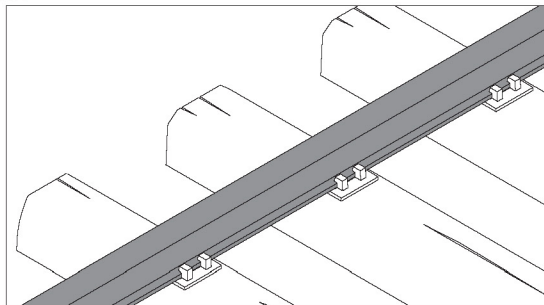
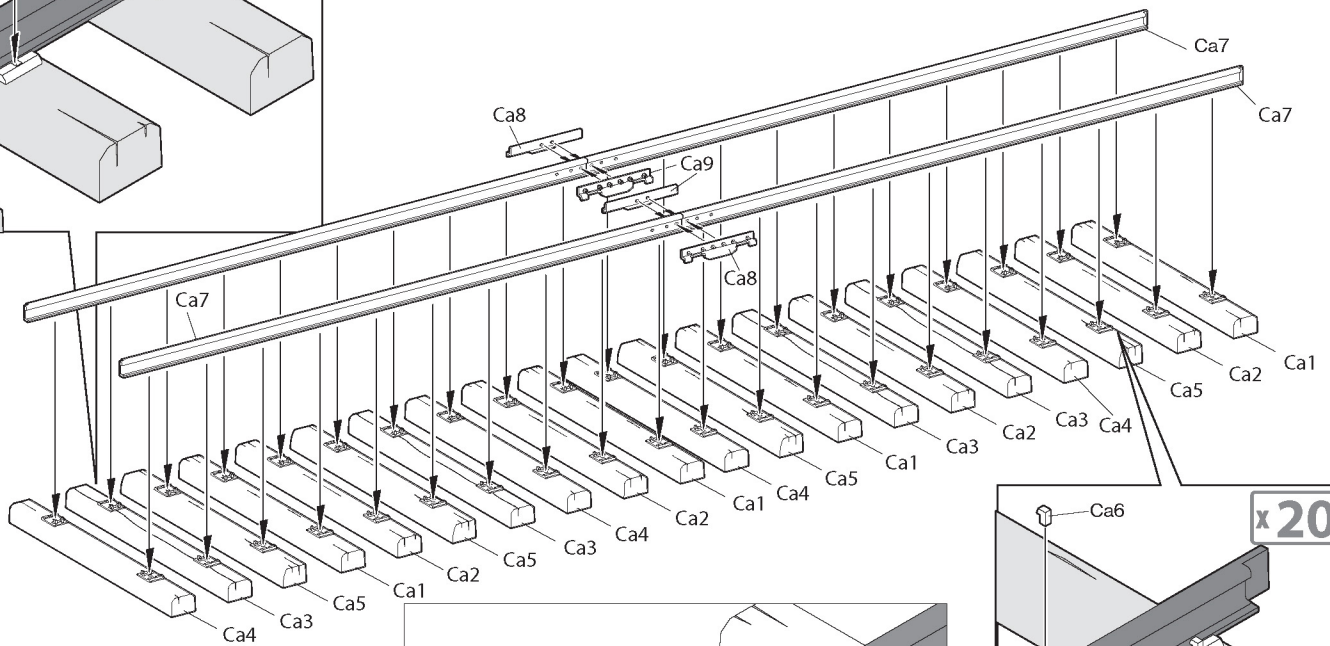

x20

37

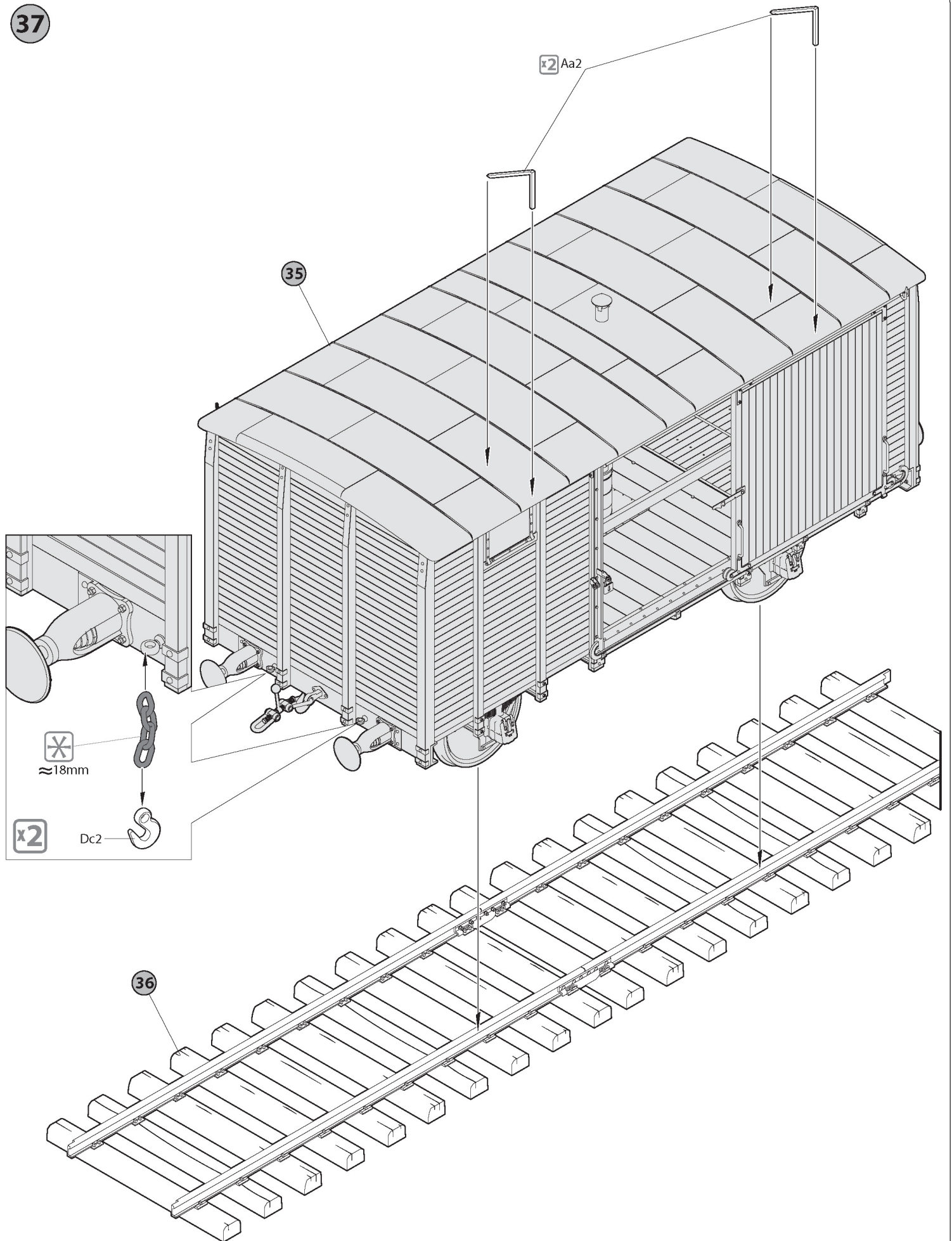

PAINTING GUIDE
ОКРАСКА

- 4** Sanitary railway carriage
of unknown military train, 1943-1944.
Санитарный вагон неизвестного
воинского эшелона, 1943-1944 годы.



- 5** Railway carriage of unknown military train, 1942-1945.
Вагон неизвестного воинского эшелона, 1942-1945 годы.

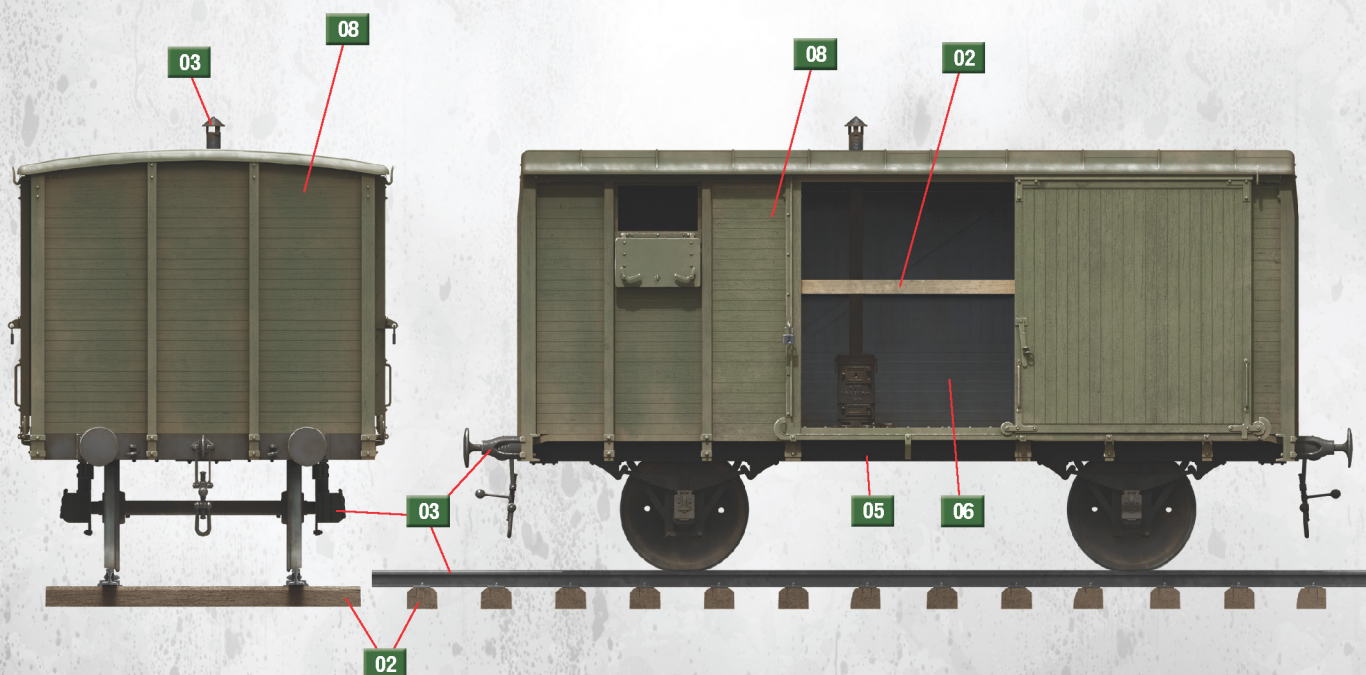

PAINTING GUIDE ОКРАСКА

6 South Ural Railway. The train car with demobilized soldiers of the Red Army, 1945.
Южно-Уральская железная дорога. Вагон поезда с демобилизованными солдатами Красной Армии, 1945 год.

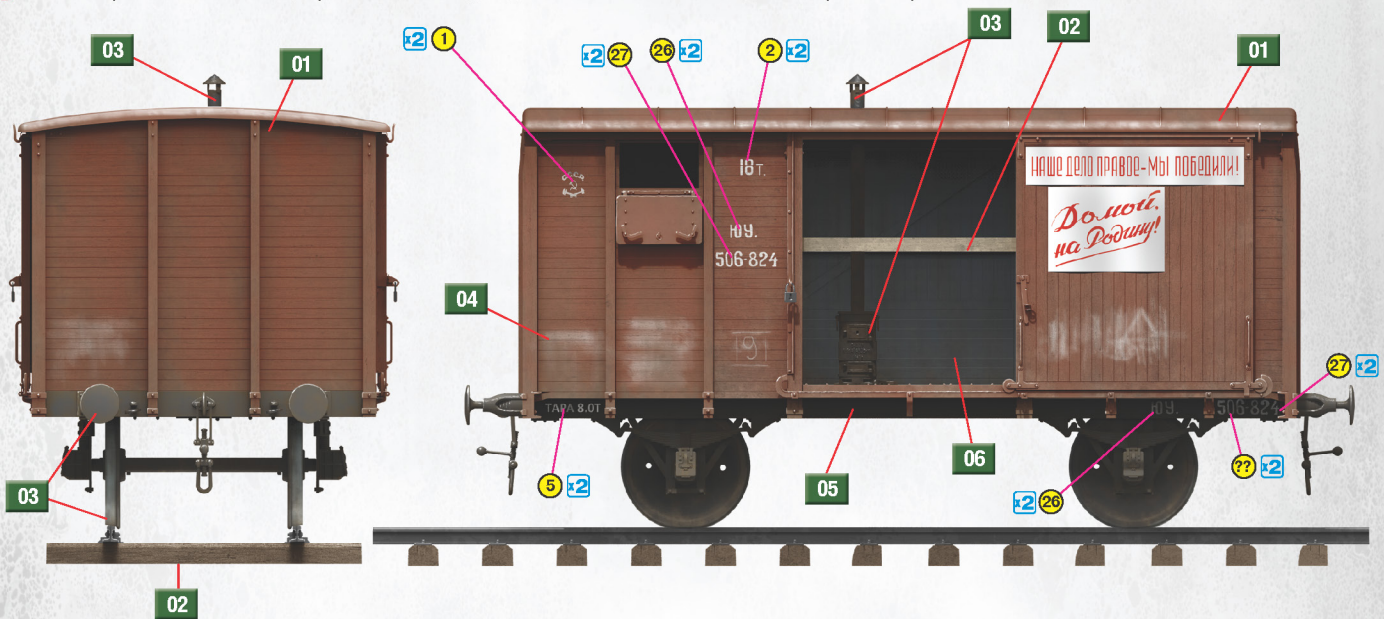

7 South-Western Railway. The train car with demobilized soldiers of the Red Army, 1945.
Юго-Западная железная дорога. Вагон поезда с демобилизованными солдатами Красной Армии, 1945 год.

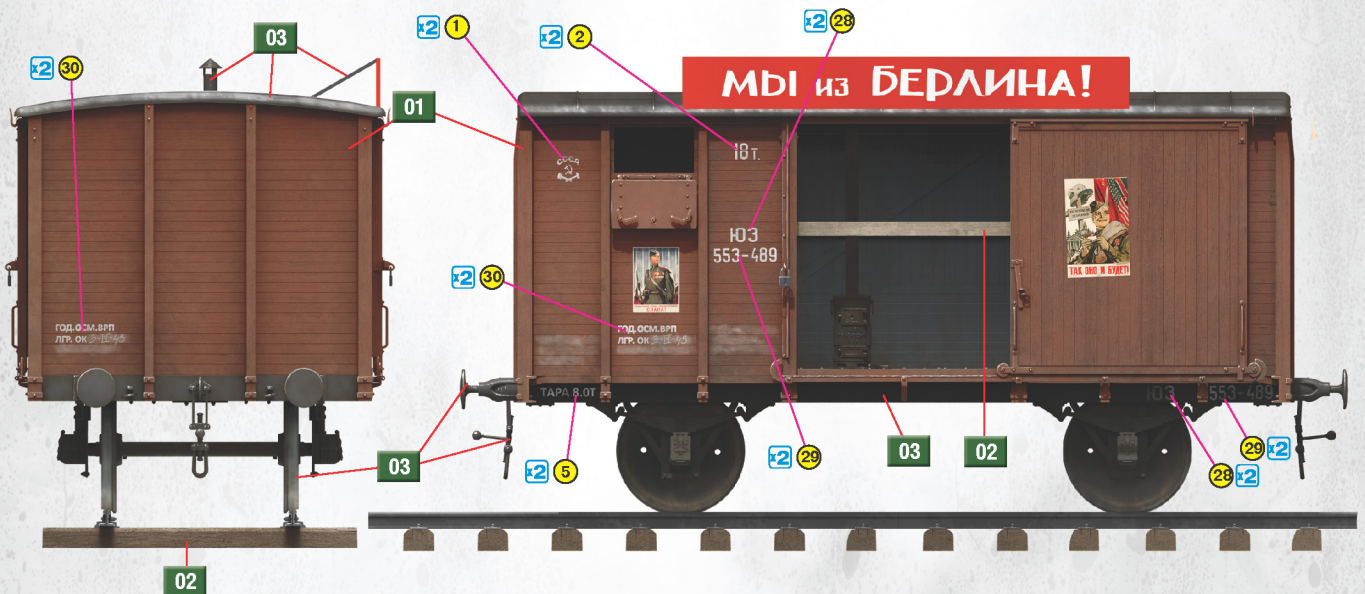

Colors Chart

Таблица цветов

№	Color/Цвет	Vallejo	Mr. Color	Life Color	Tamiya	AK	Mission Models	Hataka	Название цвета	Color name
01		71.818	029	LC-016	XF-64	RC-067	MMP-012	131	Красно-коричневый	Red Braun
02		70.311	043	UA-714	XF-78	RC-029	MMP-076	013	Дерево	Wood
03		70.863	078	LC-076	XF-84	RC-015	MMM-001	106	Вороненный металл	Gun Metal
04		70.951	062	LC-001	XF-02	RC-004	MMP-001	043	Белый	White
05		70.950	033	LC-002	XF-01	RC-001	MMP-047	041	Черный	Black
06		70.990	011	LC-018	XF-20	RC-052	MMP-072	191	Светло-серый	Light Grey
07		70.827	064	LC-011	X-15	RC-078	MMP-068	702	Лимонный зеленый	Lime Green
08		70.850	136	UA-259	XF-26	RC-076	MMP-029	316	Зеленый	Green

MINIART RAILROAD COLLECTION



SOVIET RAILWAY FLATBED 16,5-18 t

WW II MILITARY MINIATURES SERIES

Booth2018

35303



UNASSEMBLED PLASTIC MODEL KIT PE PARTS ARE INCLUDED BOX CONTAINS MODELS OF RAILWAY FLATBED DECAL SHEET IS INCLUDED

SCALE
1:35



RAILWAY GONDOLA 16,5 - 18 t

WW II MILITARY MINIATURES SERIES

- UNASSEMBLED PLASTIC MODEL KIT
- KIT CONTAINS:
 - RAILWAY GONDOLA
 - RAILWAY TRACK
 - 5 FIGURES
 - 8 FUEL DRUMS
 - PE PARTS
 - 4 DECALS
 - OPTIONS

Booth2018

35296



1:35

Booth

MINIART RAILROAD COLLECTION

EUROPEAN GAUGE

RAILWAY TRACK ^{with} DEAD END

35568

UNASSEMBLED PLASTIC MODEL KIT
90 PLASTIC PARTS
LENGTH 342 MM

SCALE **1:35**

BUILDINGS & ACCESSORIES SERIES



EUROPEAN GAUGE

RAILWAY TRACK

BUILDINGS & ACCESSORIES SERIES

UNASSEMBLED PLASTIC MODEL KIT
136 PLASTIC PARTS
LENGTH 686 MM

35561

SCALE **1:35**



CONCRETE TELEGRAPH POLES

BUILDINGS & ACCESSORIES SERIES

*THIS IS NOT A TOY *707 PLASTIC PARTS
*UNASSEMBLED PLASTIC MODEL KIT *HEIGHT 1 MM

1:35

35563



RAILROAD WATER CRANE

BUILDINGS & ACCESSORIES SERIES

*THIS IS NOT A TOY *50 PLASTIC PARTS
*UNASSEMBLED PLASTIC MODEL KIT *HEIGHT 175 MM

1:35

35567



RAILWAY SEMAPHORE

BUILDINGS & ACCESSORIES SERIES

*THIS IS NOT A TOY *102 PLASTIC PARTS
*UNASSEMBLED PLASTIC MODEL KIT *HEIGHT 243,6 MM

1:35

35566



RAILROAD POWER POLES AND LAMPS

BUILDINGS & ACCESSORIES SERIES

*THIS IS NOT A TOY *70 PLASTIC PARTS
*UNASSEMBLED PLASTIC MODEL KIT *HEIGHT 247 MM *HEIGHT 259 MM

1:35

35570

35570

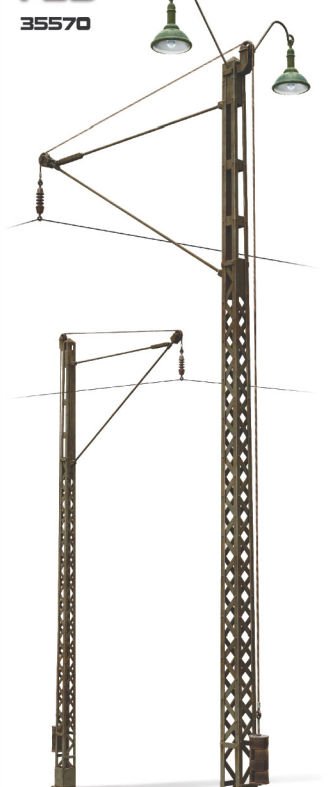

MiniArt

PEDESTRIAN BRIDGE

35522

L: 576 mm
W: 170 mm

1:35

BUILDINGS AND ACCESSORIES SERIES



MiniArt

RAILWAY TOOLS & EQUIPMENT

BUILDINGS & ACCESSORIES SERIES

35572

UNASSEMBLED PLASTIC MODEL KIT *THIS IS NOT A TOY *BOX CONTAINS 456 SET TOOLS & EQUIPMENT *FOR HOBBYLANDS AGE 14 AND OVER

SCALE **1:35**

