

Pz.Kpfw. III Ausf.D

35169

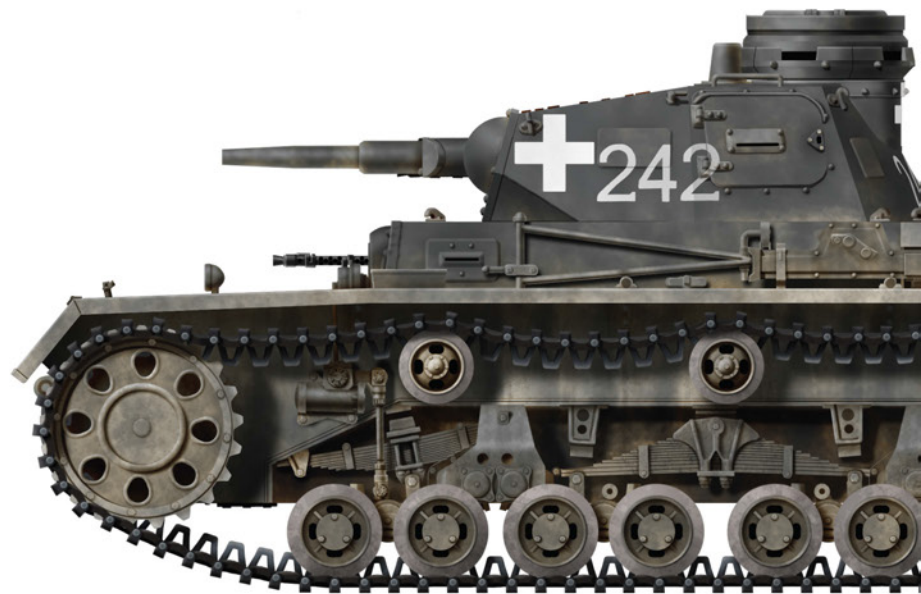
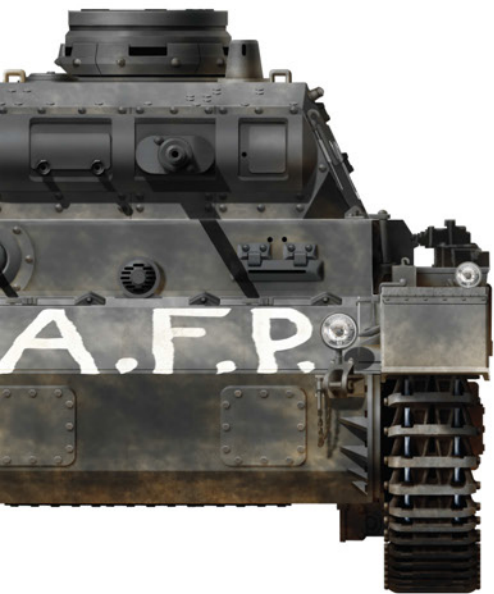

GENERAL INSTRUCTION

- HIGHLY DETAILED MODEL
- TOTAL DETAILS 1125
- 1043 PLASTIC PARTS
- 71 PE PARTS
- 11 CLEAR PLASTIC PARTS
- DECALS SHEET FOR 4 OPTIONS
- FULL-COLOUR INSTRUCTION
- WORKABLE CHASSIS
- WORKABLE TRACK LINK
- FULLY DETAILED INTERIOR OF TURRET
- CREWS VISION PERISCOPES WITH CLEAR PLASTIC PARTS
- ALL HATCHES CAN BE ASSEMBLED OPENED OR CLOSED

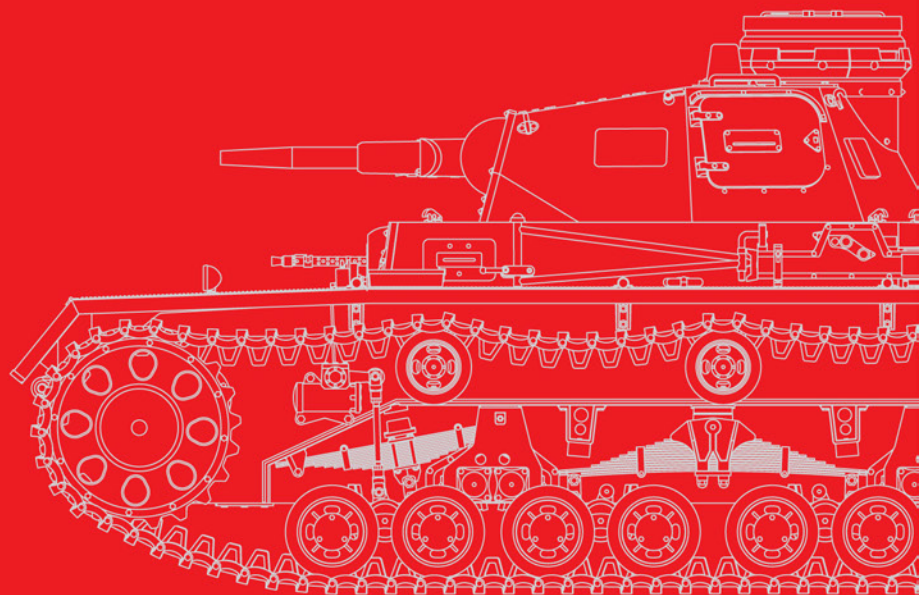

MiniART : 35169



The Ausf D was the fourth of the development series for an armoured vehicle in the 15 ton class.

The suspension was again improved over previous vehicles by inclining the leaf-spring assemblies supporting the first and last pairs of road wheels, in order to increase support. The Ausf D had a newly-designed sprocket, idler and transmission. This was the last model in the series with 15mm basic armour, although a new style cupola had been introduced, with 30mm armour and five vision slits. The design of the rear deck and hull rear was changed to improve armour protection. The louvres on top were replaced by hatches which could be braced open.

During 1938, the official organization called for three Pz Kpfw III in a Zug (platoon) in the light tank company of each armoured detachment. Thus, each Panzer regiment was to have only six Pz Kpfw III and each Panzer division twelve. After action in Poland, the Ausf D was also withdrawn from the Panzer regiments in February 1940. Its front-tine service was lengthened by several months, however, when Ausf D were issued to Tank Detachment for Special Employment 40, which fought in Norway in April 1940.

Танки модификации D входили в четвертую серию 15-тонных танков. На них снова улучшена ходовая часть.

В ходовой части для её усиления были установлены наклонные листовые рессоры в подвеске первых и последних пар катков. Новые ведущие колеса, ленивцы и трансмиссия. Это были последние машины класса 15 т с 15-мм броней, но с новой формой командирской башенки, имевшей 30-мм бронирование и 5 смотровых щелей. Конструкция кормы корпуса изменена в целях повышения снарядостойкости. Жалюзи на крыше заменили на лючки, которые могли фиксироваться в открытом положении.

В 1938 г. по штату в каждой танковой роте должен иметься взвод Pz.III из трех машин. Таким образом каждый танковый полк имел всего 6 Pz.III, а танковая дивизия - 12. После боев в Польше танки Pz.III Ausf. D в феврале 1940г. были выведены из боевого состава. Для боевых действий в Норвегии в апреле 1940 г. их свел в 40-й танковый отряд специального назначения.

Technical characteristics Panzerkampfwagen III Ausf. D (Sd. Kfz. 141)

Manufacturer:	Daimler-Benz
Release time:	1938
Crew:	5 (commander, gunner, loader, driver, radio operator/bowmachine-gunner)
Weight:	19,8 tonnes
Length, mm:	5920
Width, mm	2820
Height, mm:	2420
Engine:	Maybach HL 108TR
Engine power:	250 hp
Maximum speed:	40 km/h
Maximum range:	165 km
Radio	Fug 5
Armour (mm):	5-15 mm
Armament	
Gun:	1 × 37-мм KwK 36
Machine gun:	3 × 7,92-мм MG-34

Технические характеристики Panzerkampfwagen III Ausf. D (Sd. Kfz. 141)

Завод-изготовитель:	Daimler-Benz
Время выпуска:	1938
Экипаж:	5 (командир, наводчик, заряжающий, водитель, радист)
Боевая масса:	19,8 т.
Длина, мм	5920
Ширина, мм	2820
Высота, мм	2420
Двигатель:	Maybach HL 108TR
Максимальная мощность:	250 л.с.
Максимальная скорость:	40 км/ч
Запас хода по шоссе, км	165 км
Радиостанция:	Fug 5
Броня (мм):	5-15 мм
Вооружение	
Пушка	1 × 37-мм KwK 36
Пулеметы:	3 × 7,92-мм MG-34



MAKE 2PCS
2 TEILE FERTIGEN
EFFETUER 2 PIECES
FARE DUE PEZZI
TEE 2 KPL
GÖR 2 ST
ПОВТОРИТЬ ДВА РАЗА
КІЛЬКІСТЬ РАЗІВ



DO NOT CEMENT
NICHT KLEBEN
NE PAS COLLER
NON INCOLLARE
EILIMMÄ
LIMMAEJ
НЕ ИСПОЛЬЗОВАТЬ КЛЕЙ
НЕ КЛЕПТИ



OPTIONAL
NACH BELIEBEN
FACULTATIVO
FACOLTATIVO
VALINNANVARAINEN
VALBAR
ВАРИАНТЫ
ВАРИАНТИ



OPEN HOLE
OFFENEN
FAIRE UN TROU
FORO APERTO
AVAA REIKÄ
OPPNÄ HULET
СДЕЛАТЬ ОТВЕРСТИЕ
ЗРОБИТИ ОТВІР



REMOVE
ENTFERNEN
SEPARARE
SEPARARE
POISTA
AVJÄGGA
ОТРЕЗАТЬ
ВІДРІЗАТИ



BEND
BITTE BIEGEN
PLIER S'IL VOUS PLAÎT
PIEGARE
TAIJA
BOCCA
ВЫГНУТЬ
ВІГНУТИ



SCRATCHBUILD
AM MEISTEN ZU MACHEN
FAIRE LE PLUS
RENDITI
RENDITI
TEE ITSE
GÖR DIG SJÄLV
СДЕЛАТЬ САМОМУ
ЗРОБИТИ САМОМУ



PARTS NOT FOR USE
TEILE WERDEN NICHT
VERWENDET
NEST PAS UTILISÉ
PARTI NON PER L'USO
OSIA EI KÄYTTÄ
INTE FÖR ANVÄNDNING
НЕ ВИКОРИСТОВУЄТЬСЯ
НЕ ВИКОРИСТОВУЄТЬСЯ

Ac x4

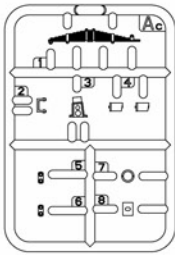

Ad x4

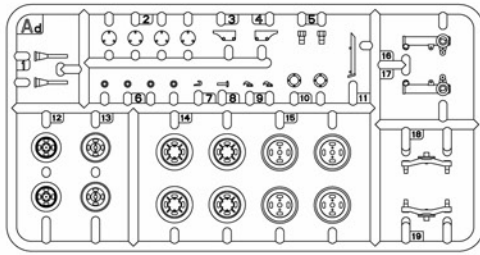

Ae x4

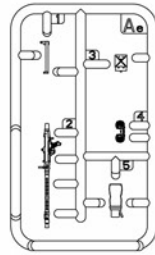

Af x2

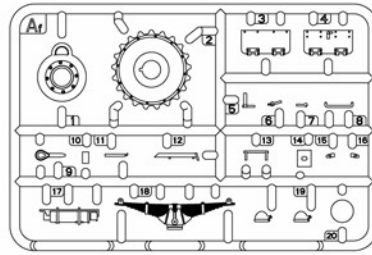

Ba

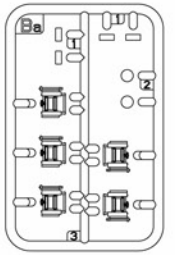

Bc x2

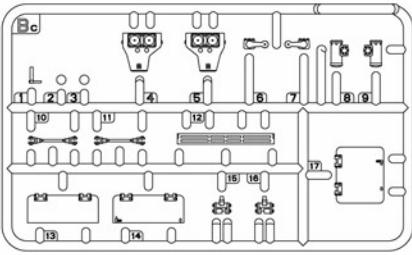

Bd x2

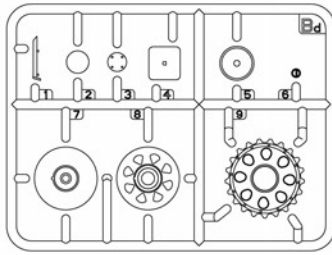

Be

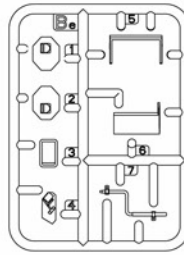

Bf

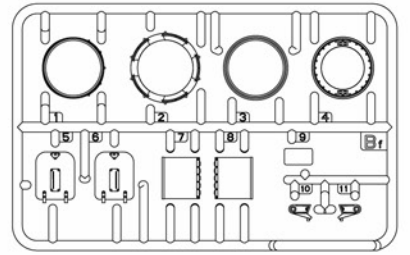

C

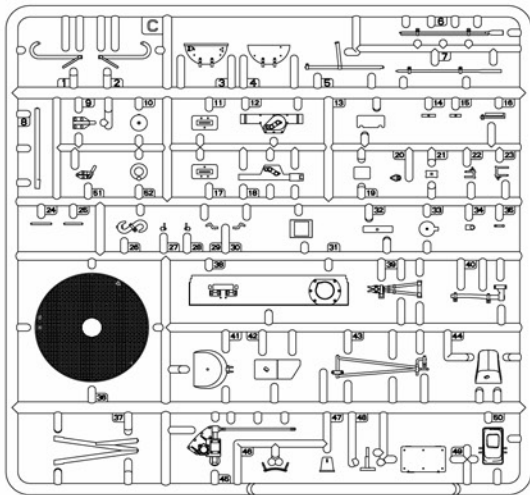

Ca

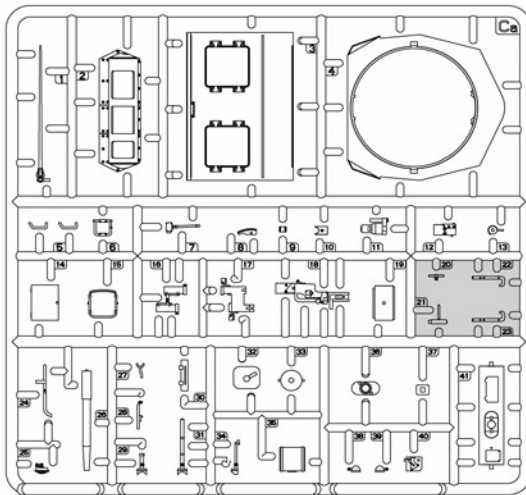

L x4

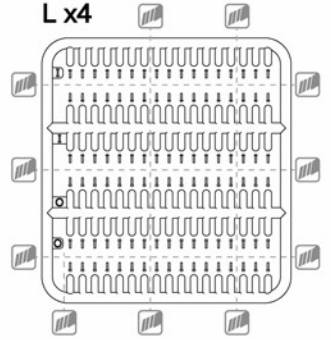

PE

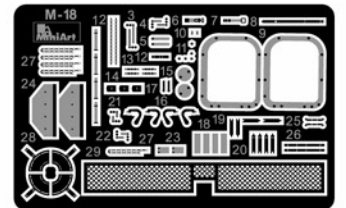

K x18



Decal/Деколь

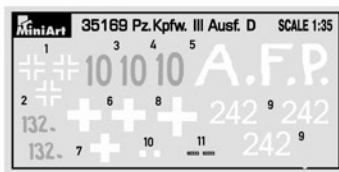

F

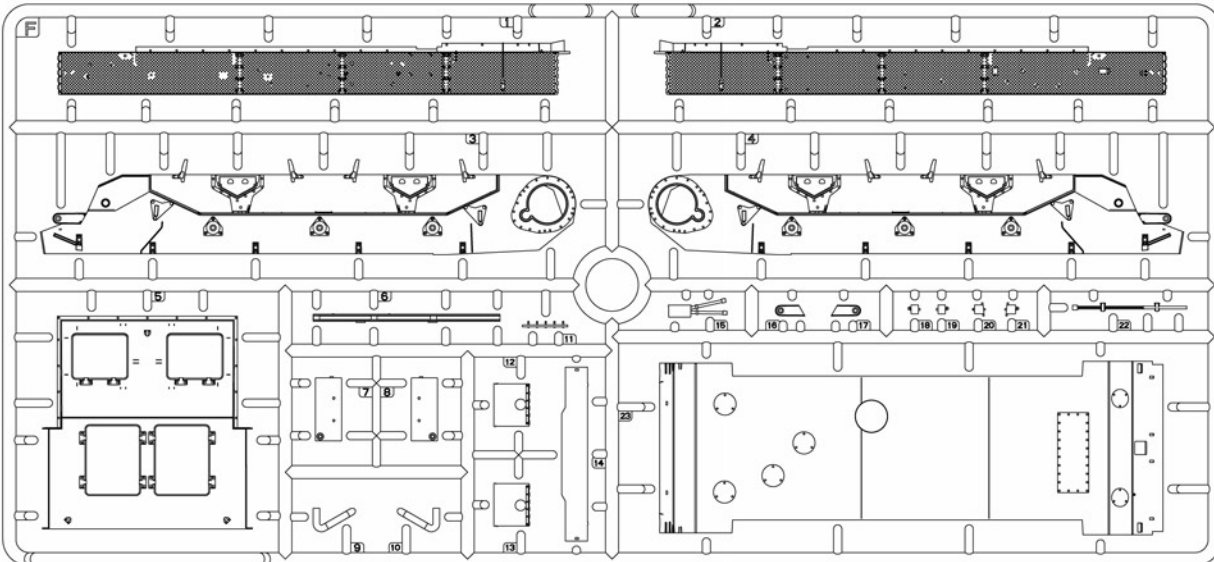

tool for assembly track link
инструмент для сборки траков

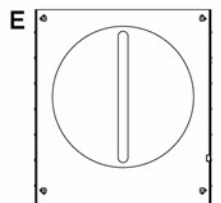
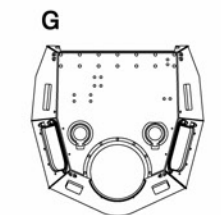

1

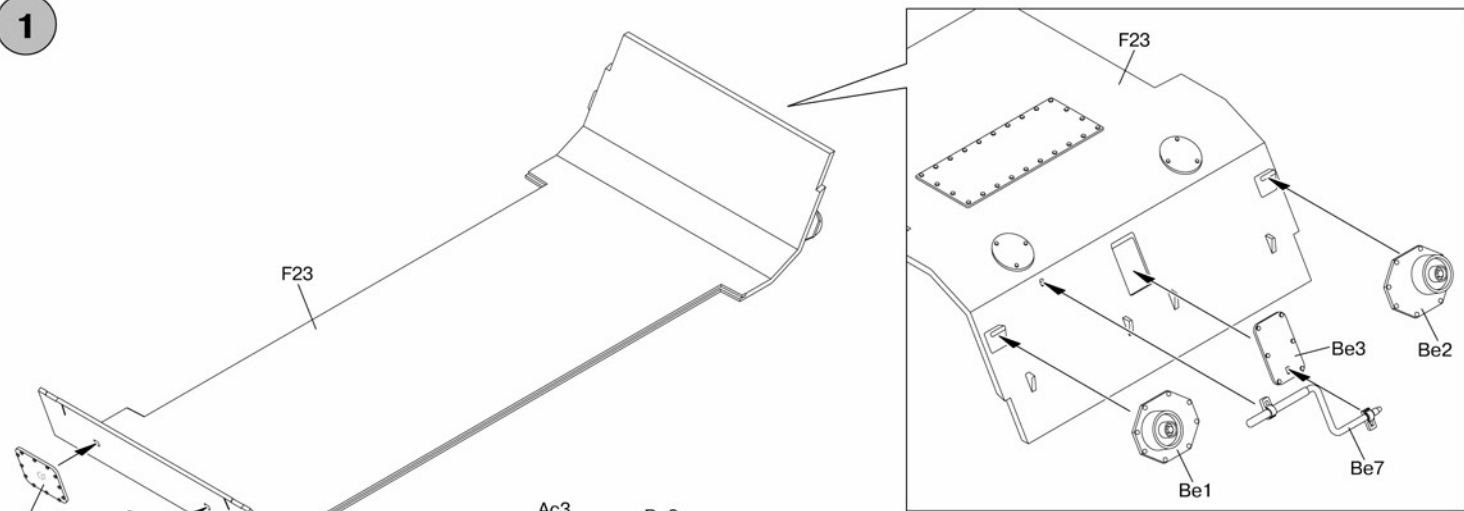

2

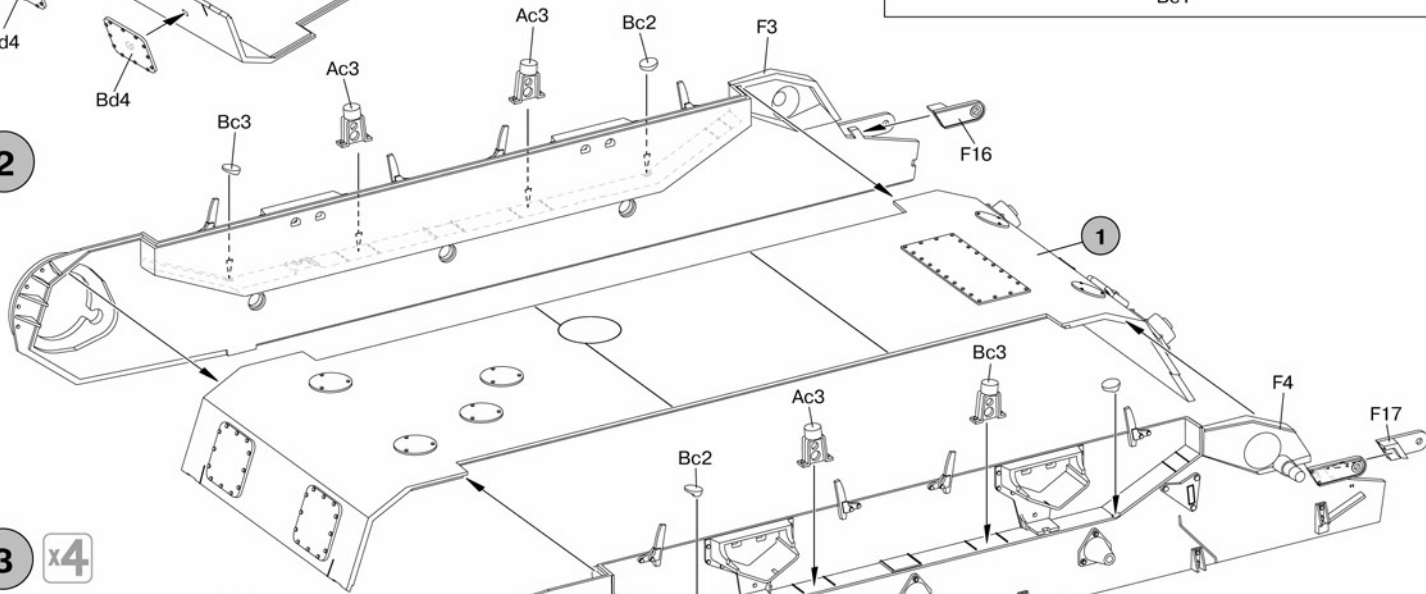

3

x4

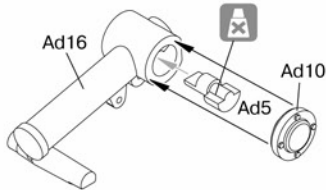

4

x4

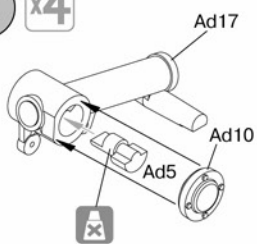

5

x4

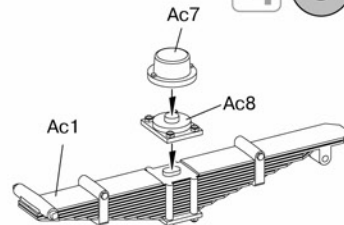

6

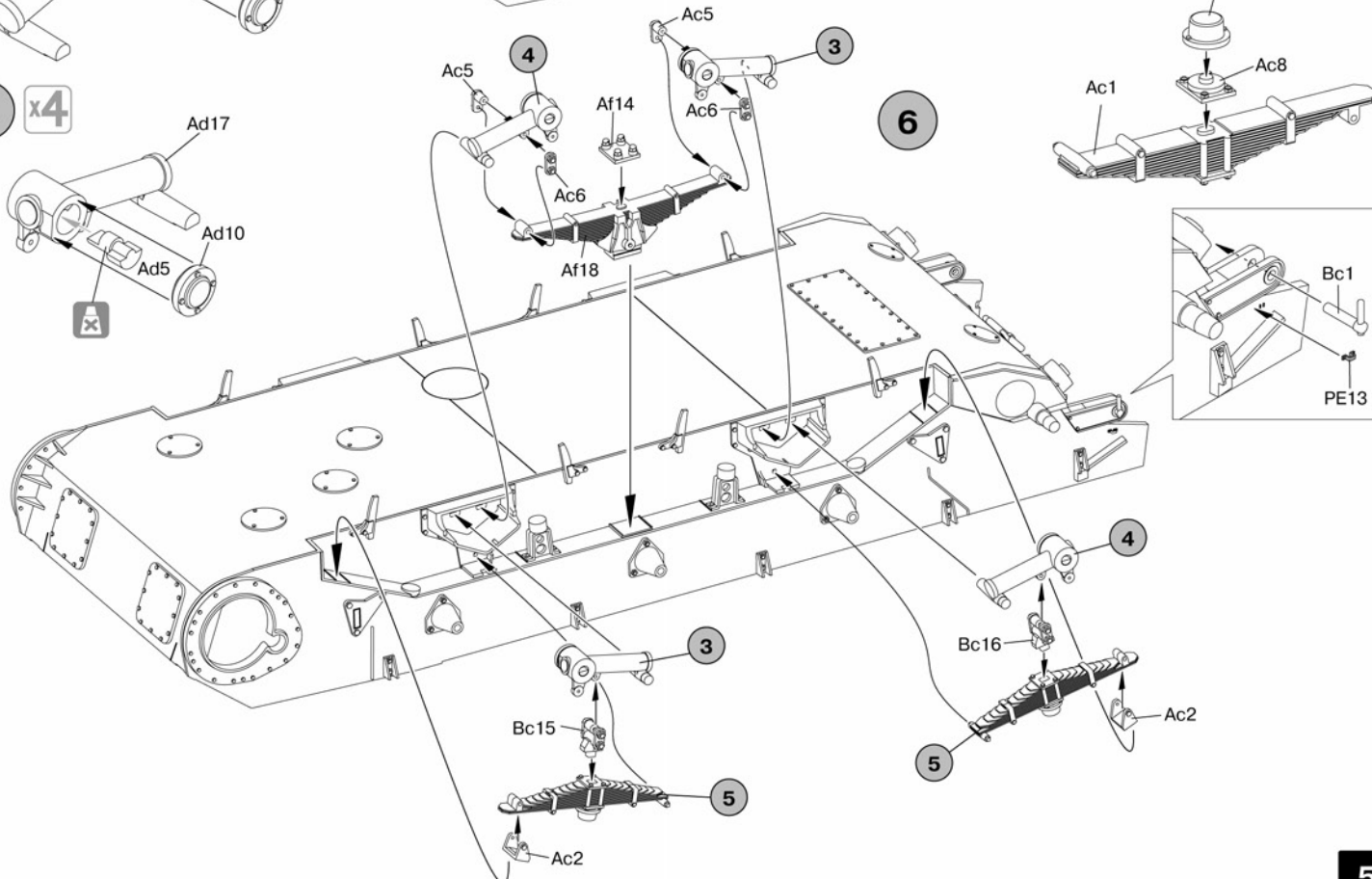

5

7

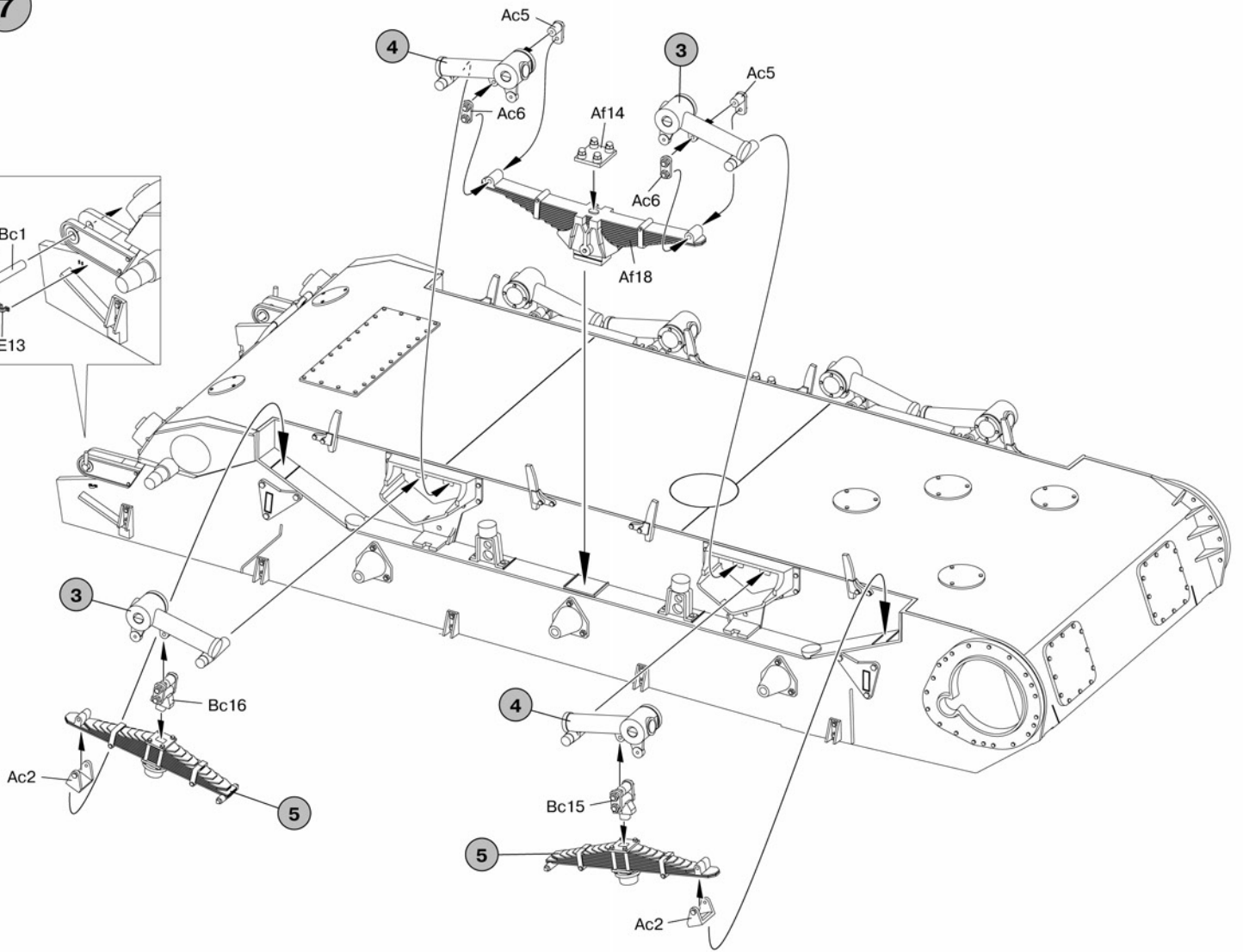
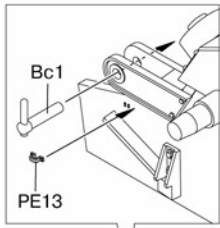

8

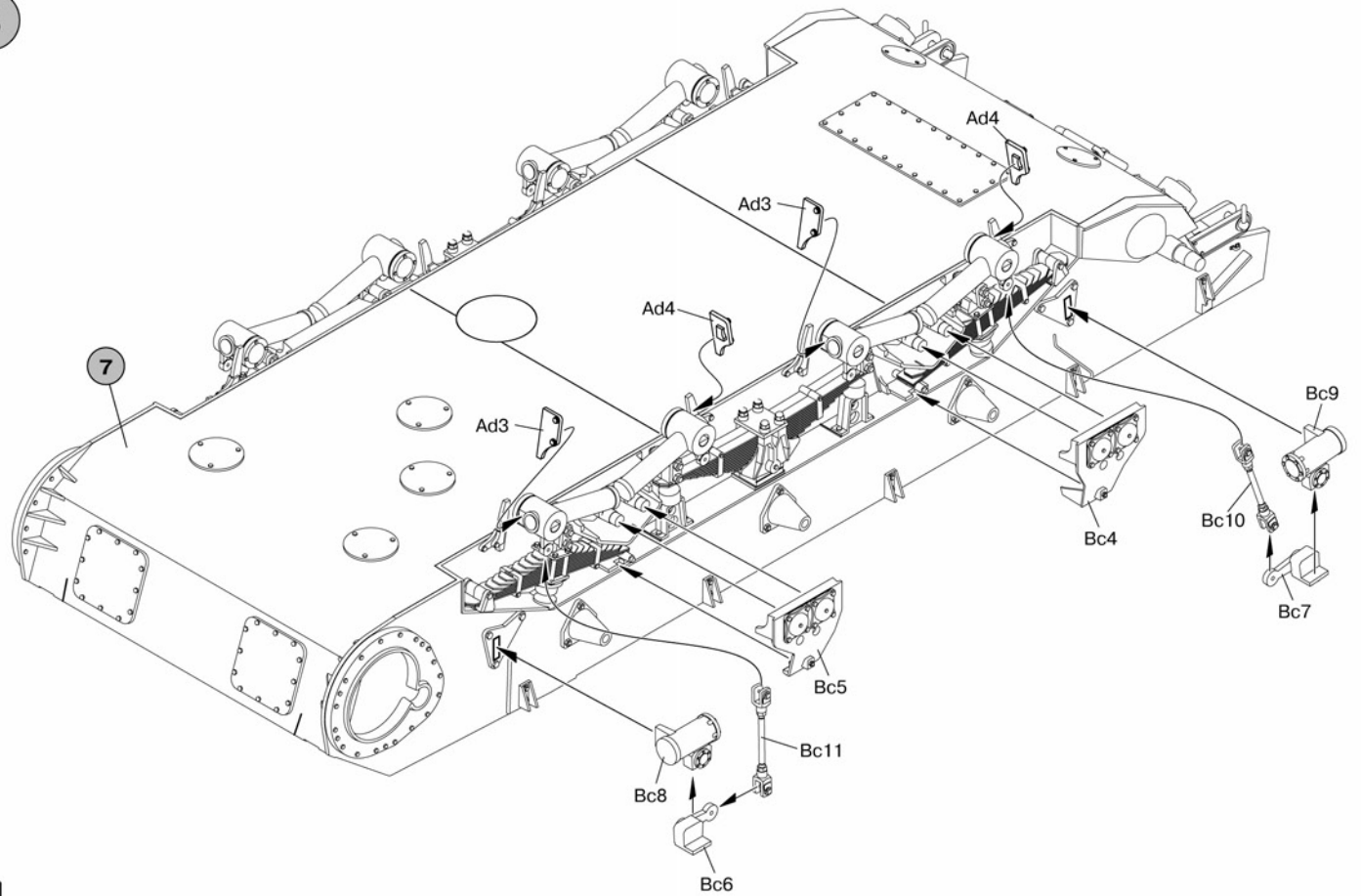

6

9

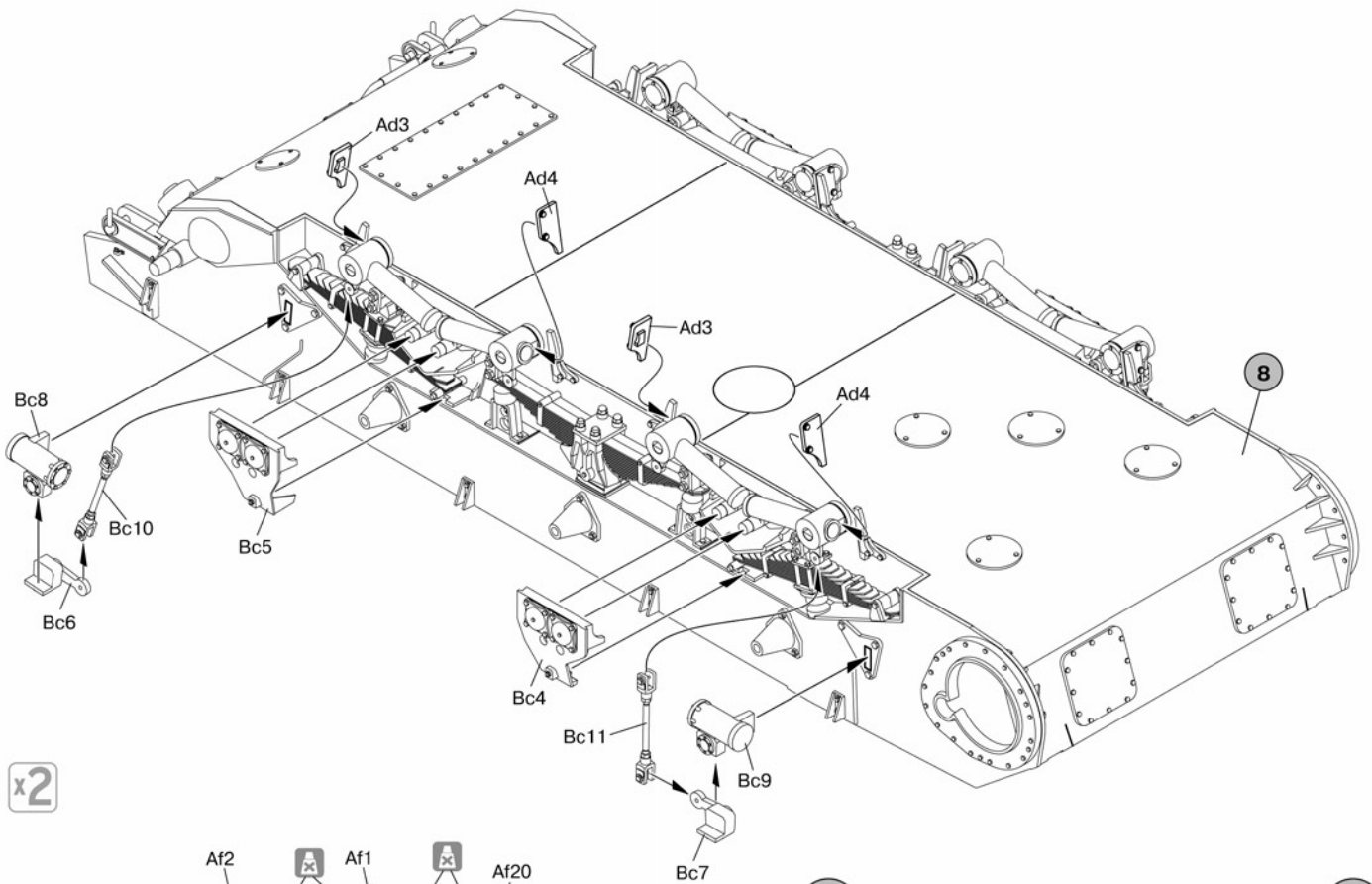

10 x2

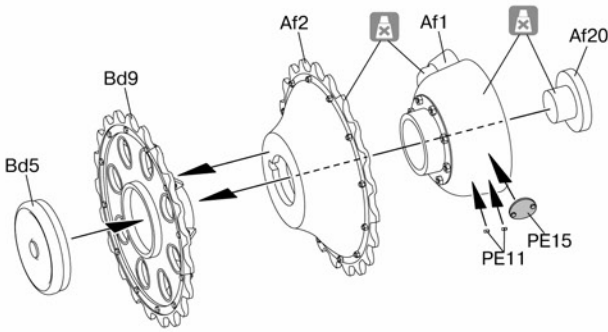

11

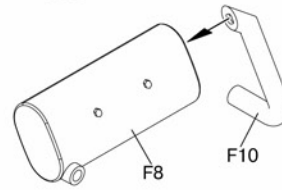

12

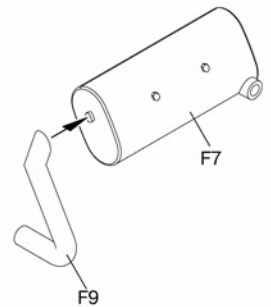

13

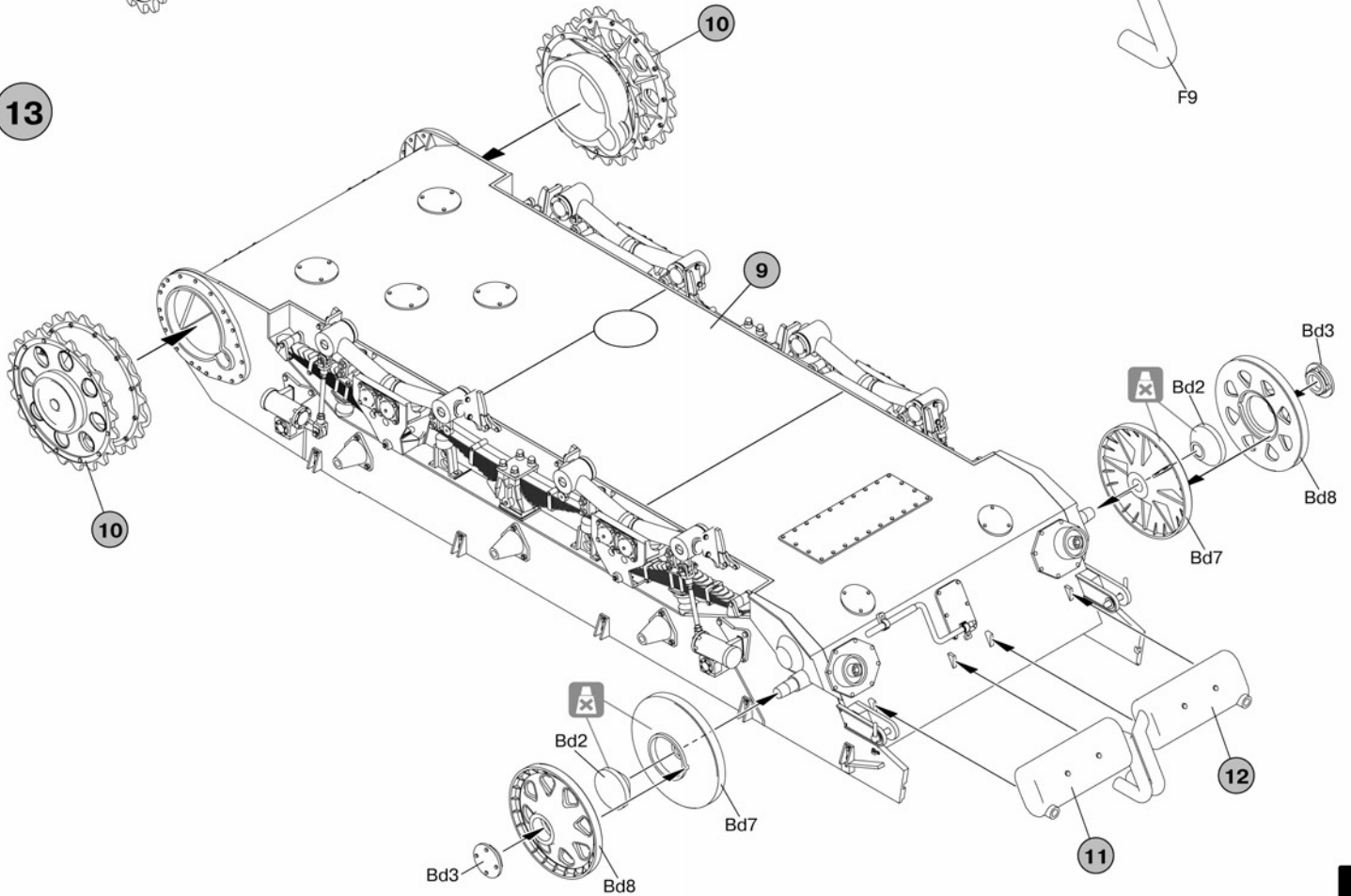

14 x4

x4 15

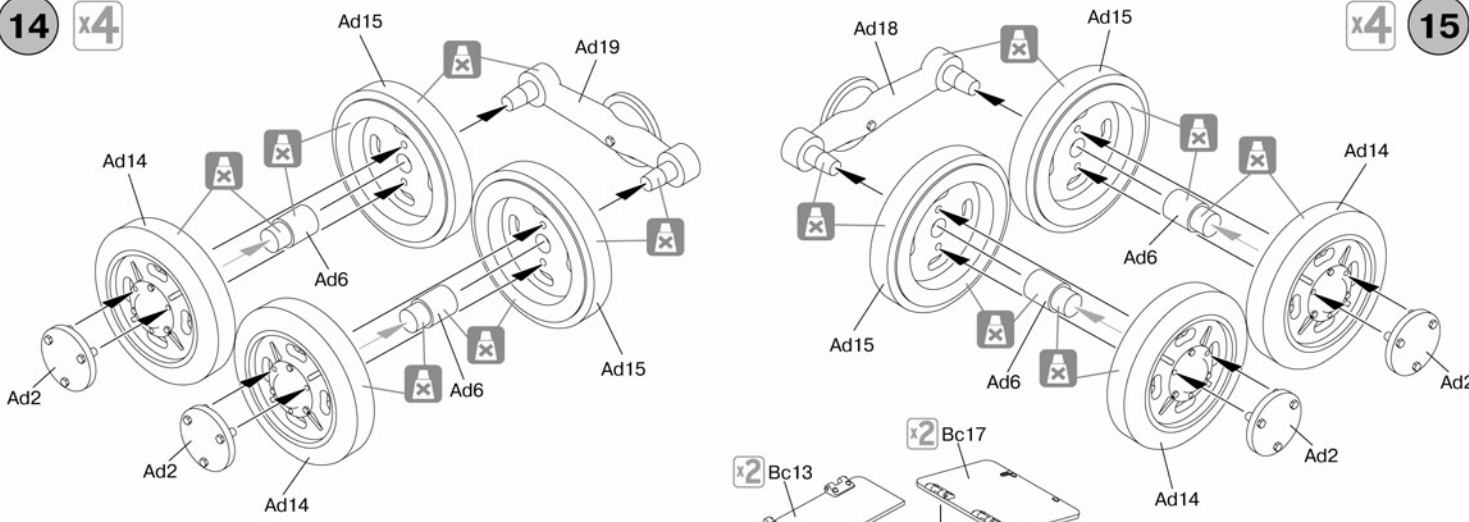

16

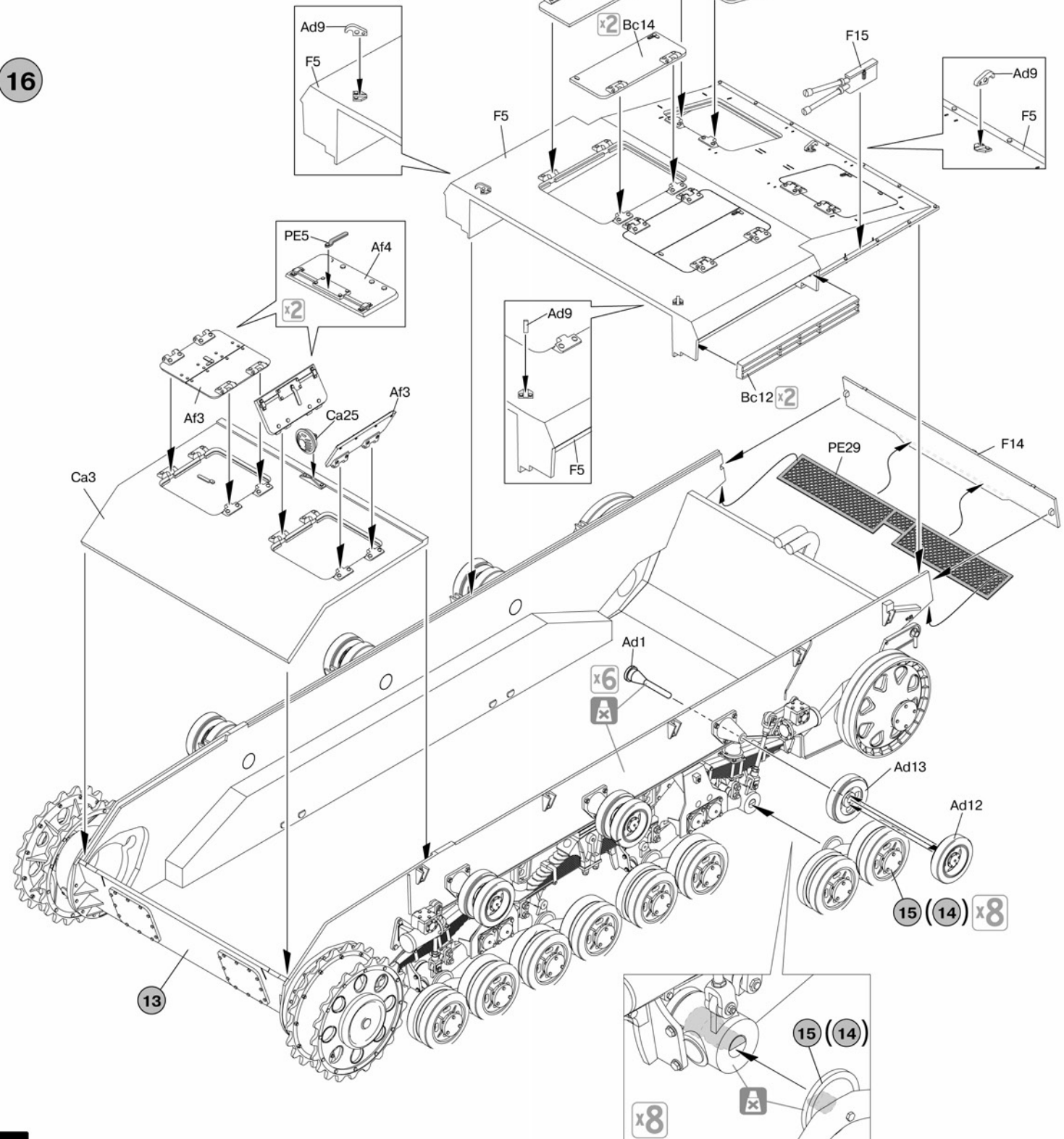

17

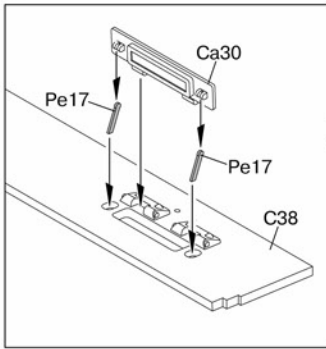

x3 18

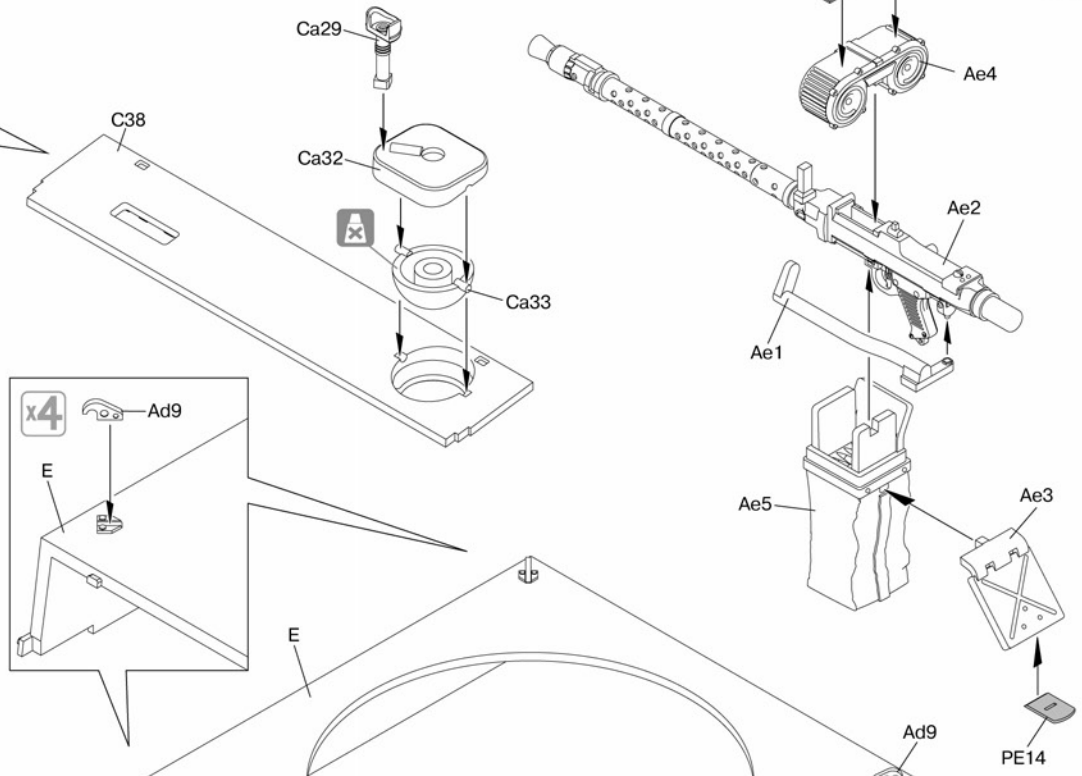

19

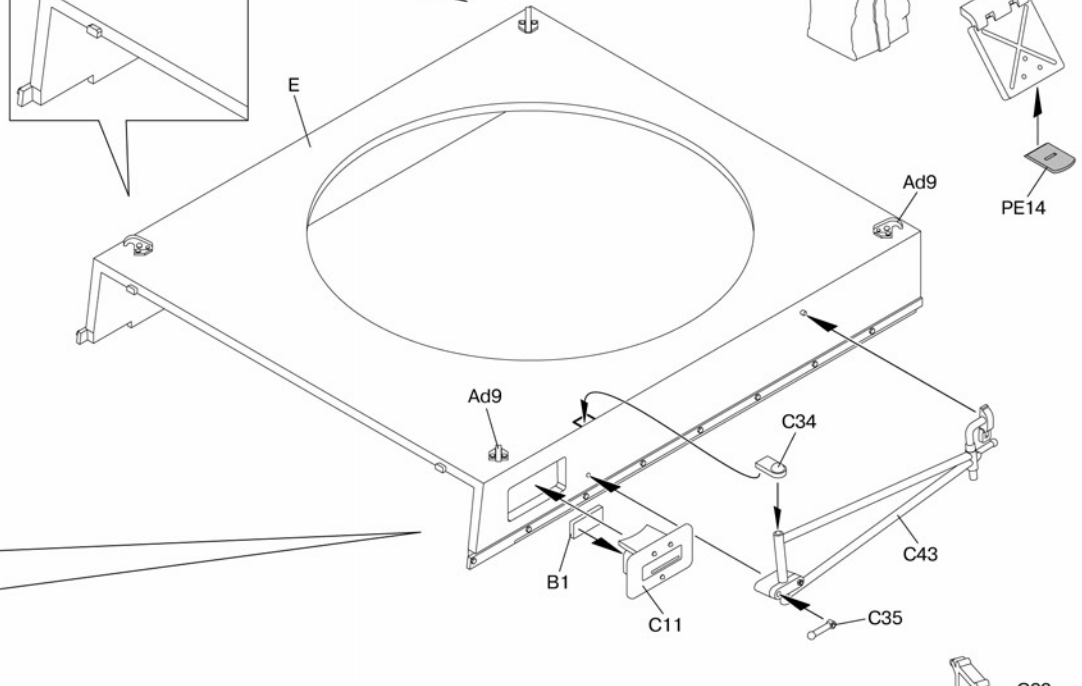
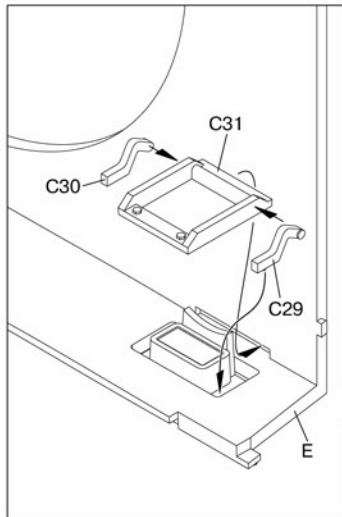
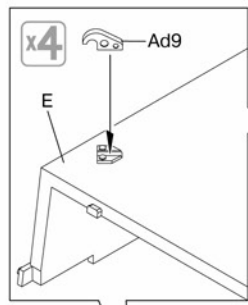

20

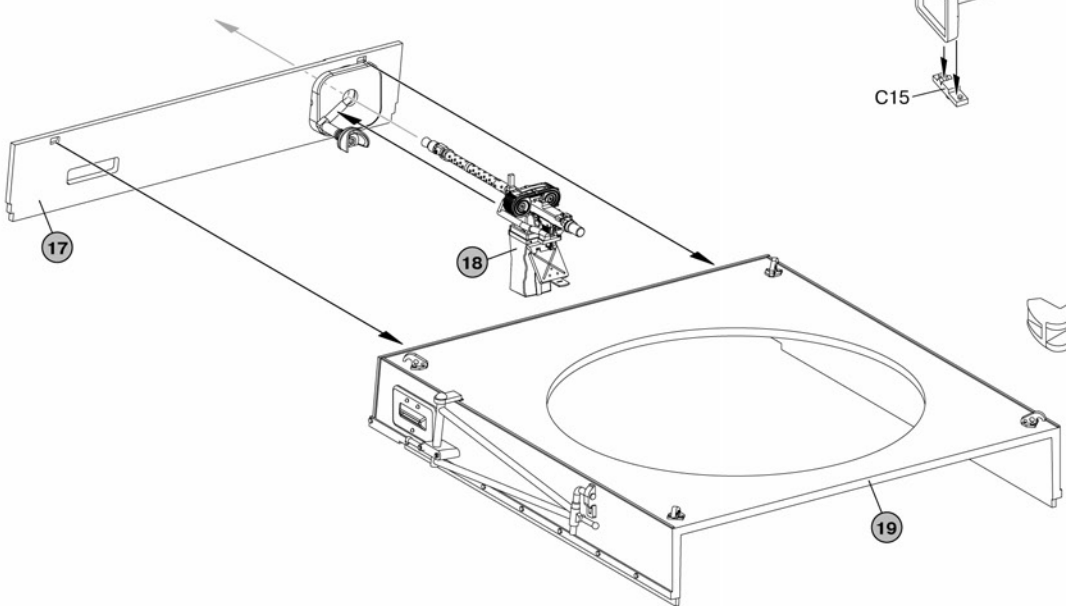

21

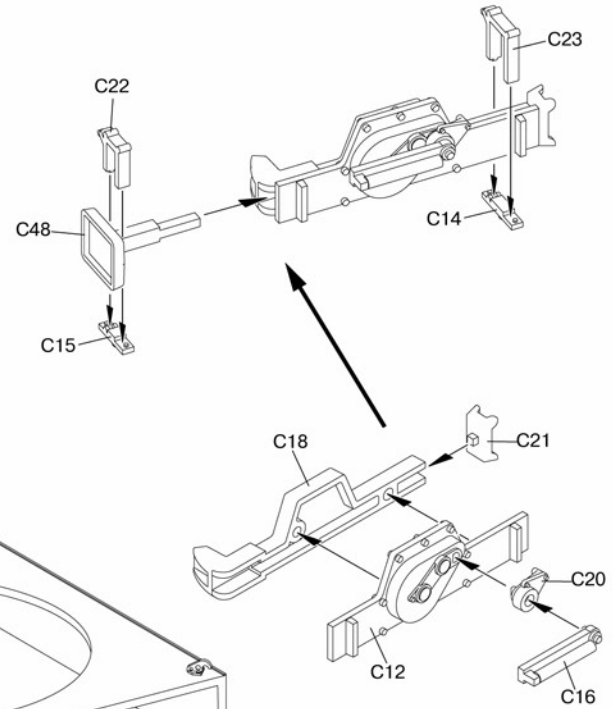

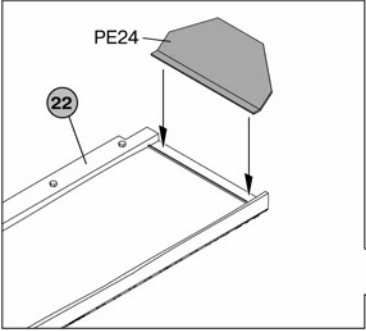
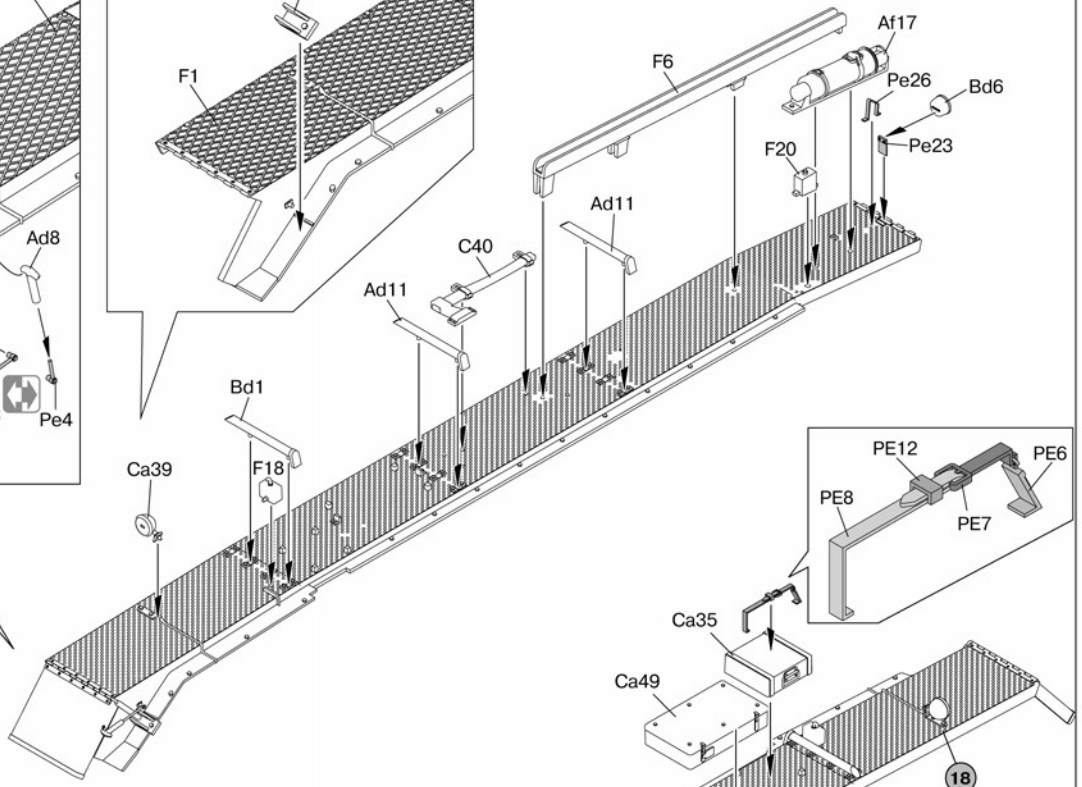
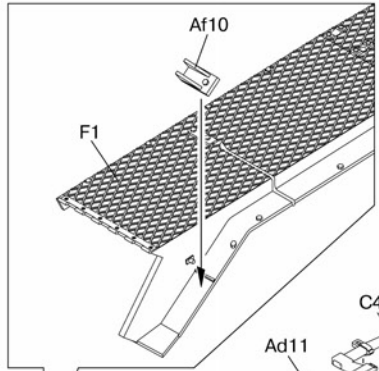
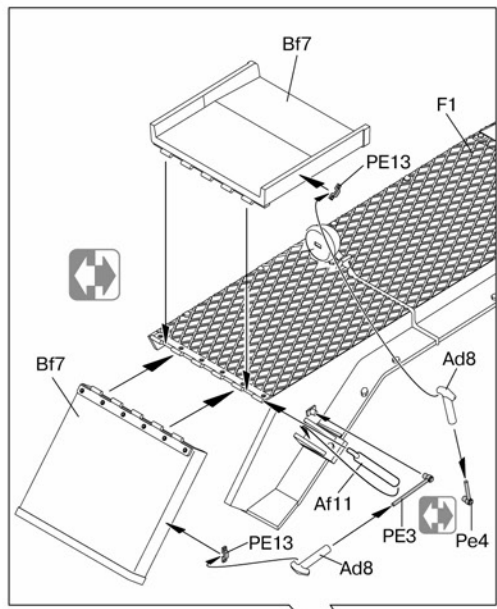

23

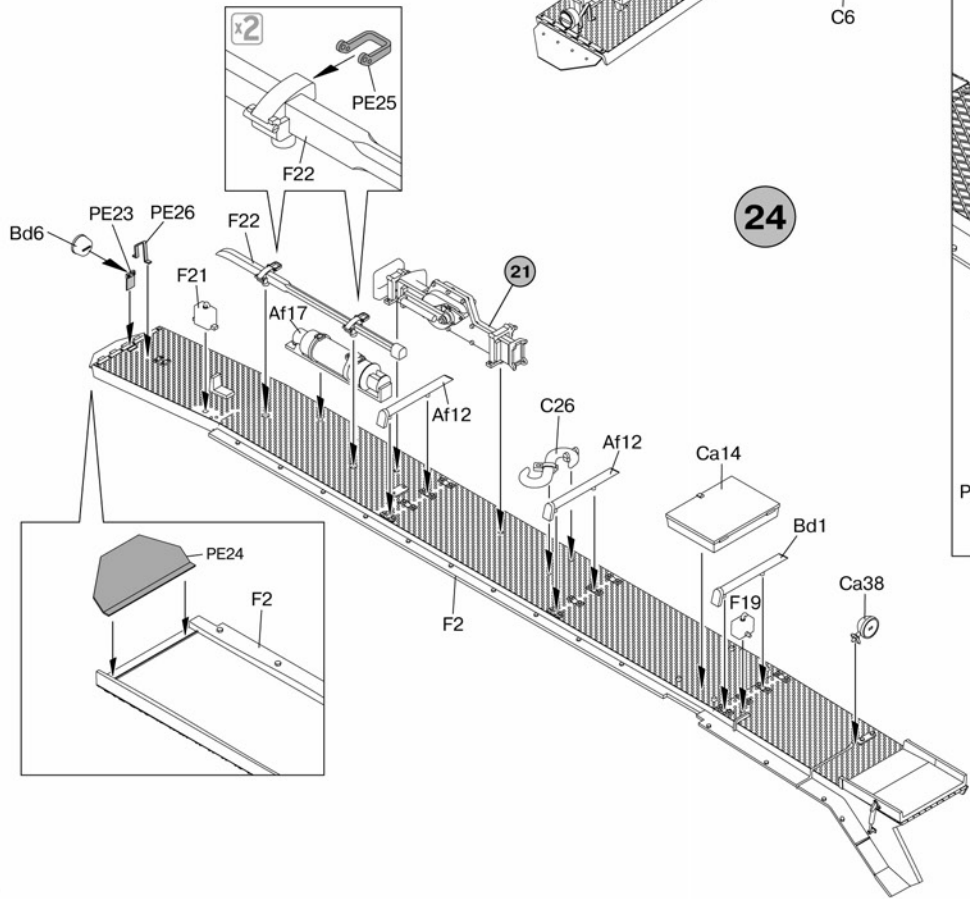

24

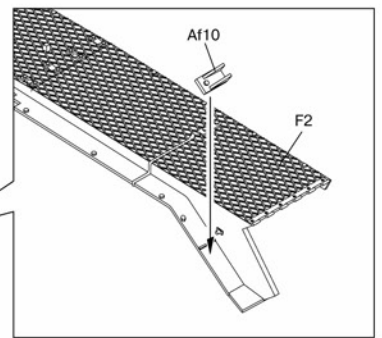
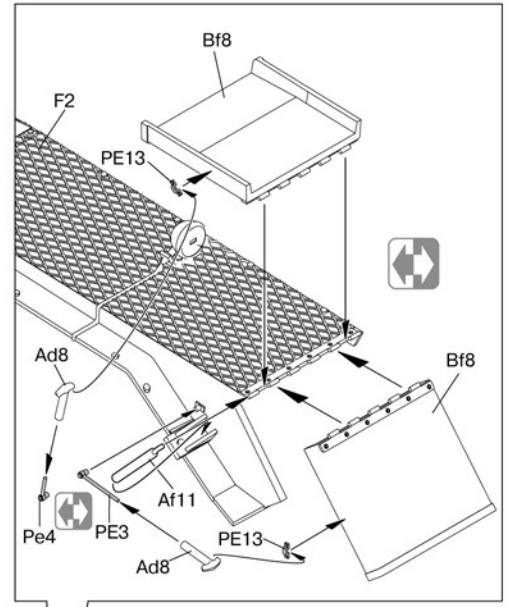

25

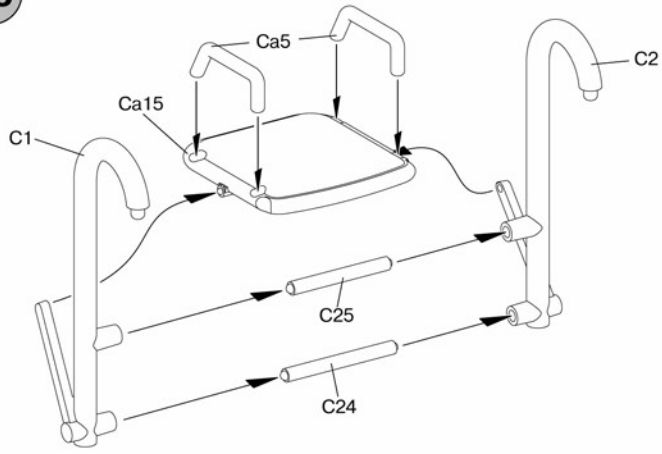

28

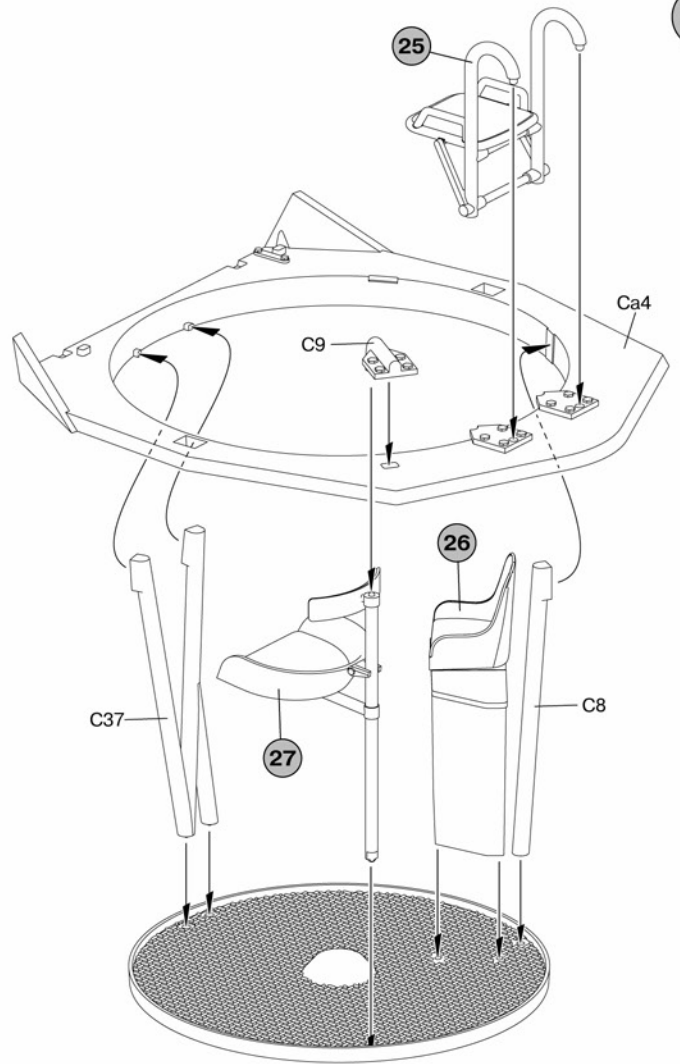

26

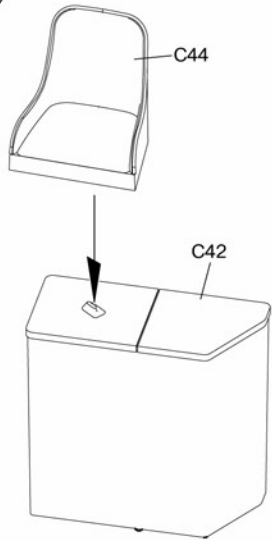

27

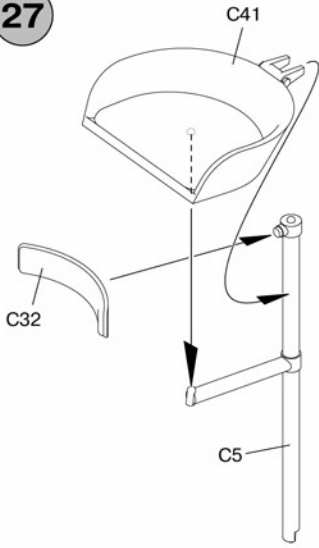

29

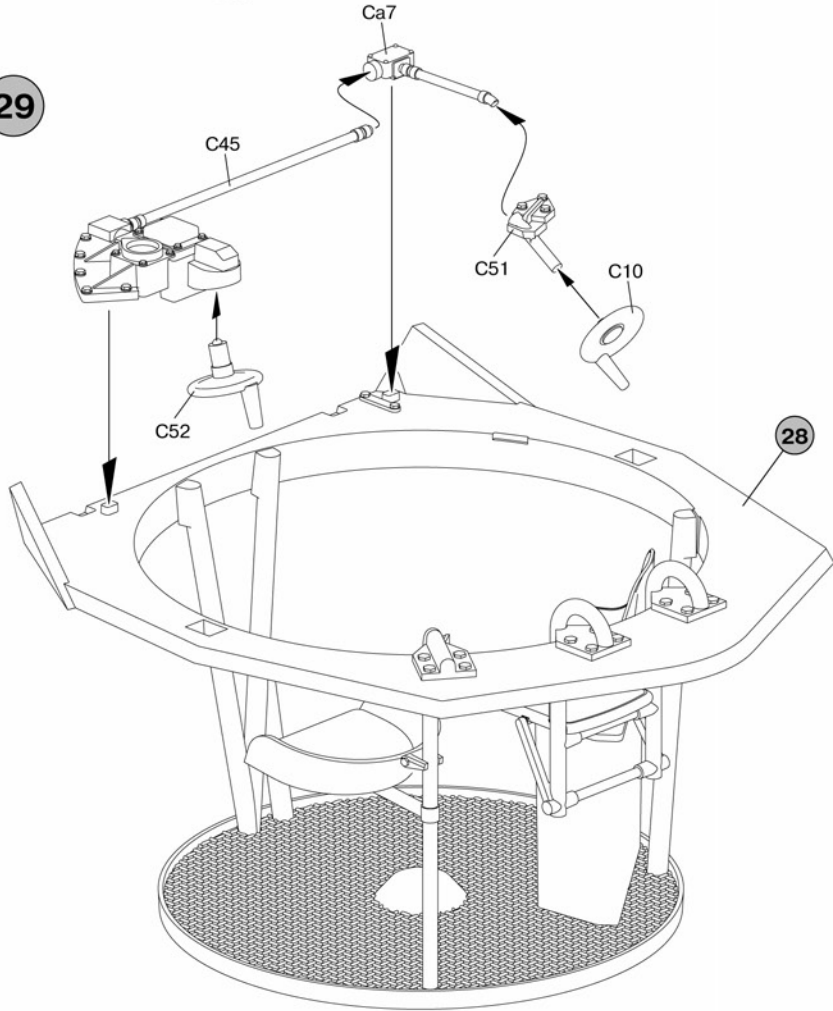

30

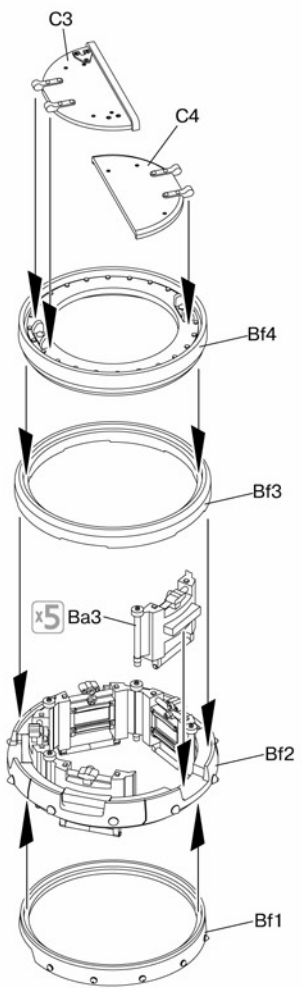

31

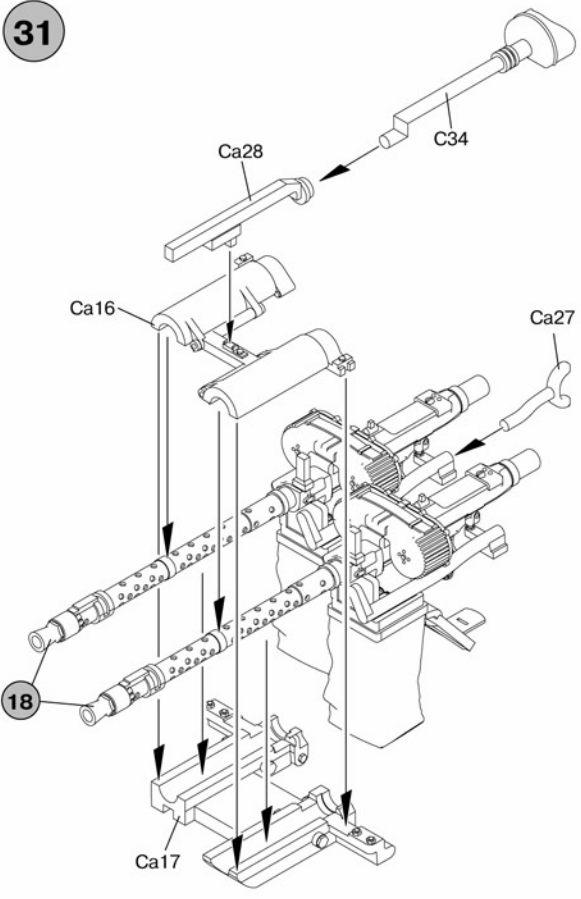

32

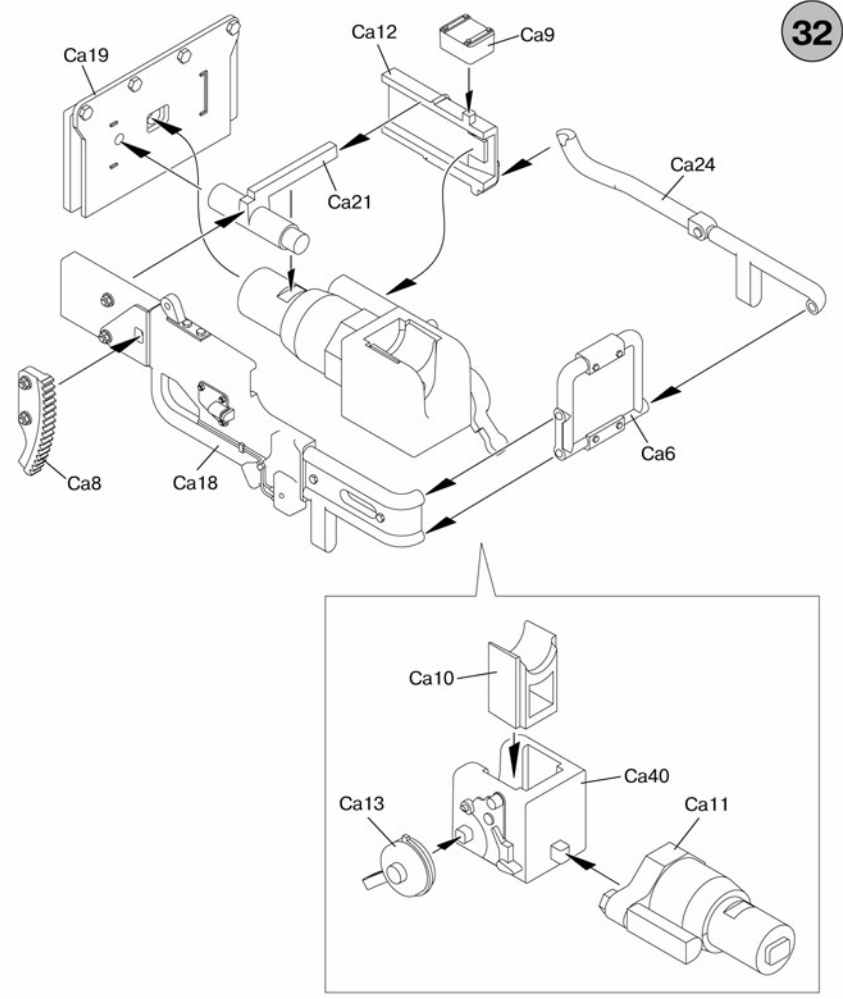

33

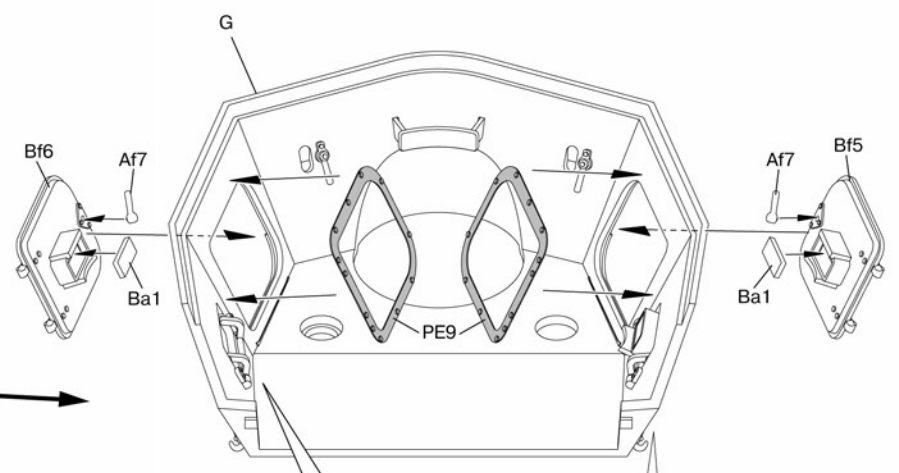
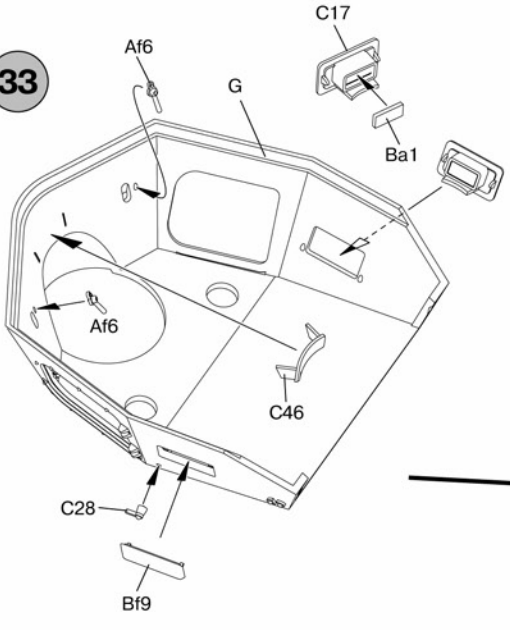

34

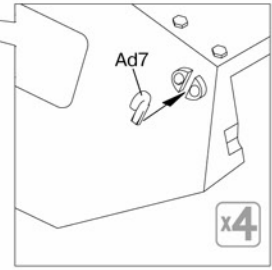
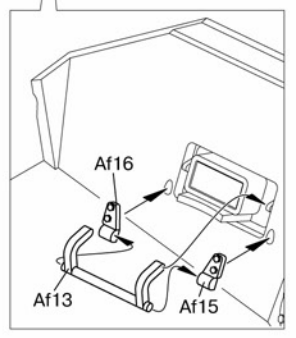
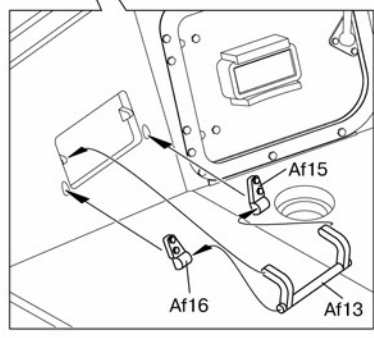
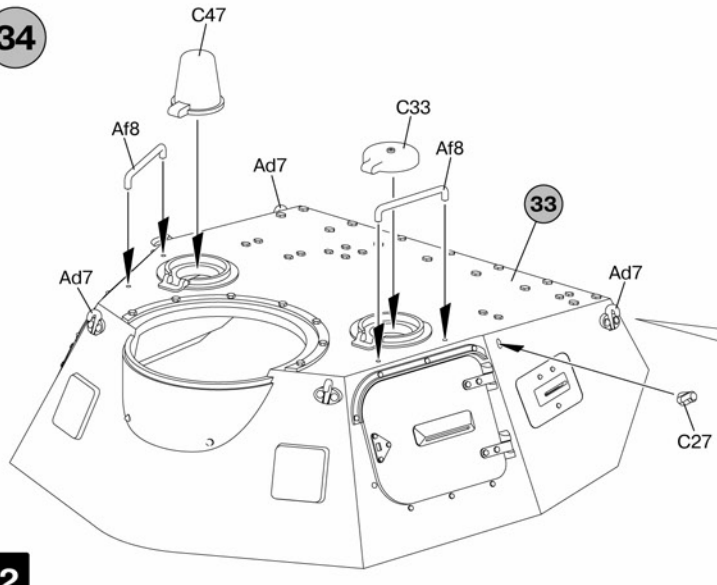

35

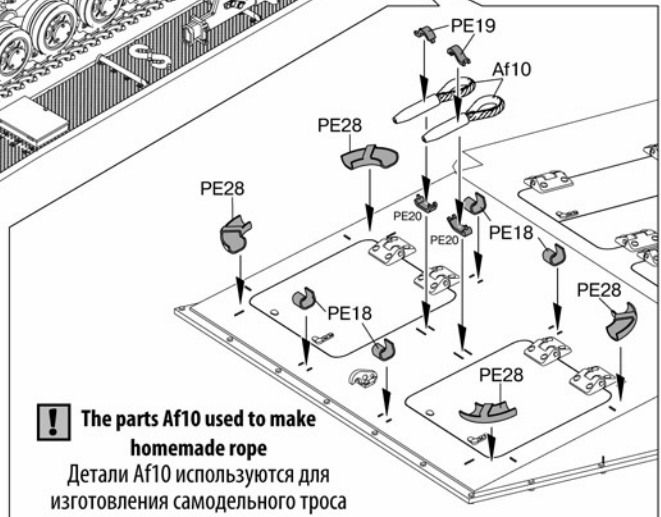
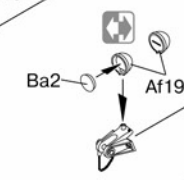
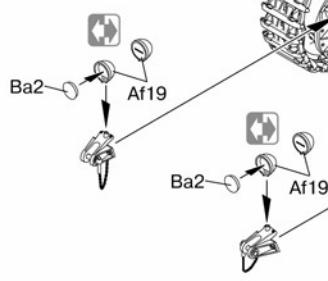
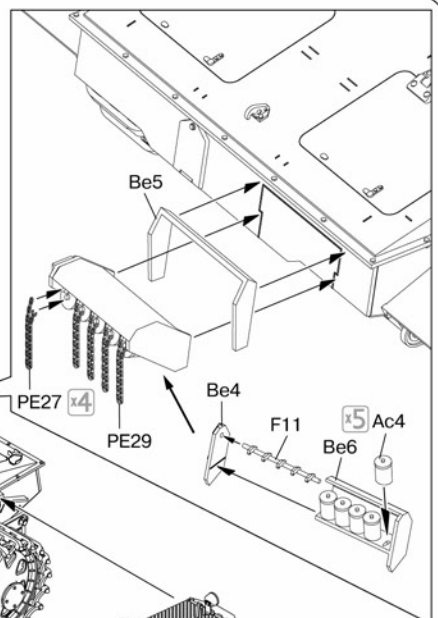
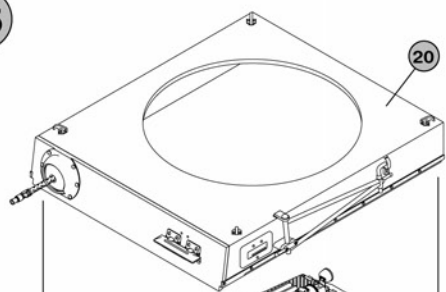
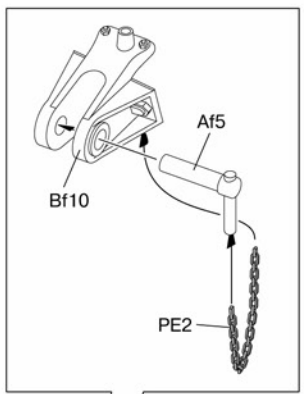

! The parts Af10 used to make homemade rope
 Детали Af10 используются для изготовления самодельного троса

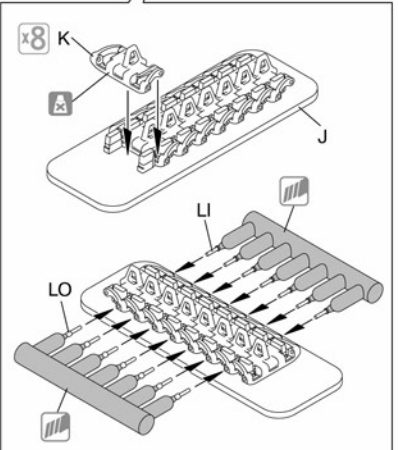
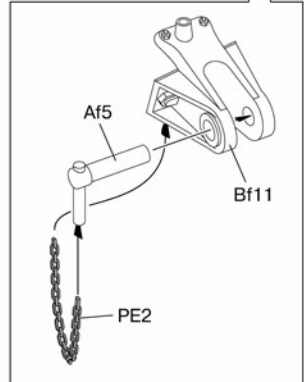

each track link contains 96 tracks
 гусеничная лента состоит из 96 траков

37

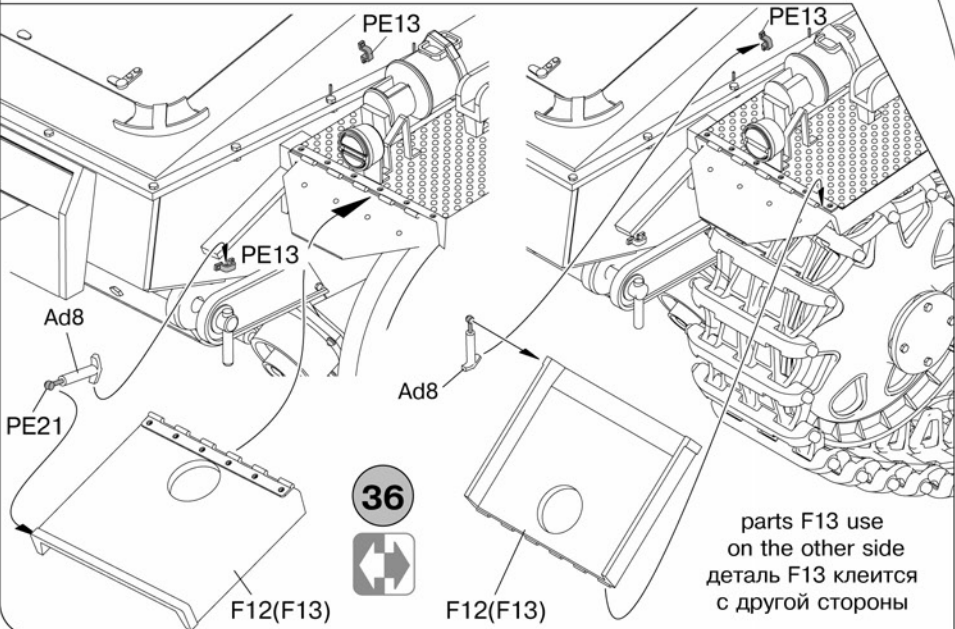
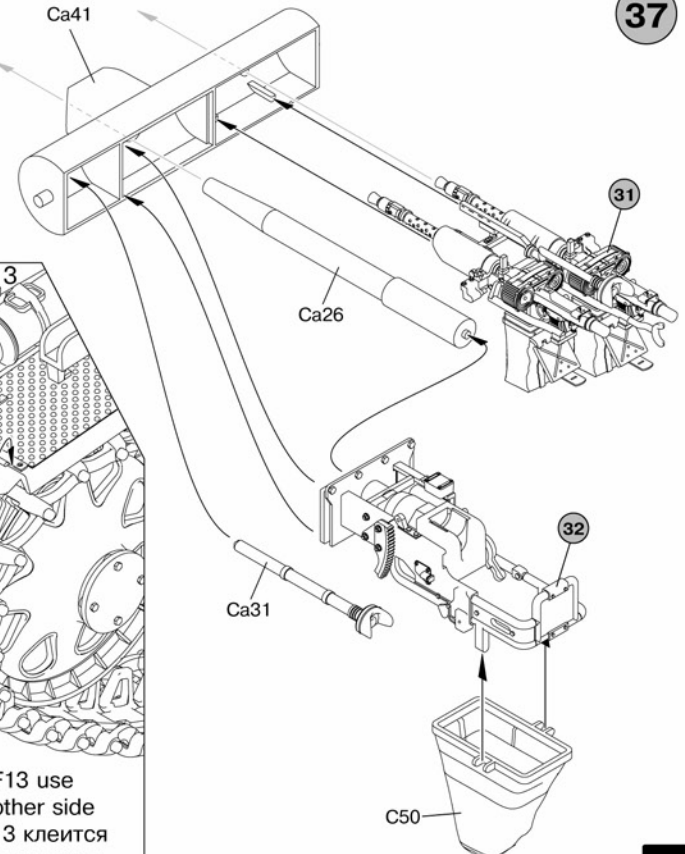

36

parts F13 use on the other side
 деталь F13 клеится с другой стороны

13

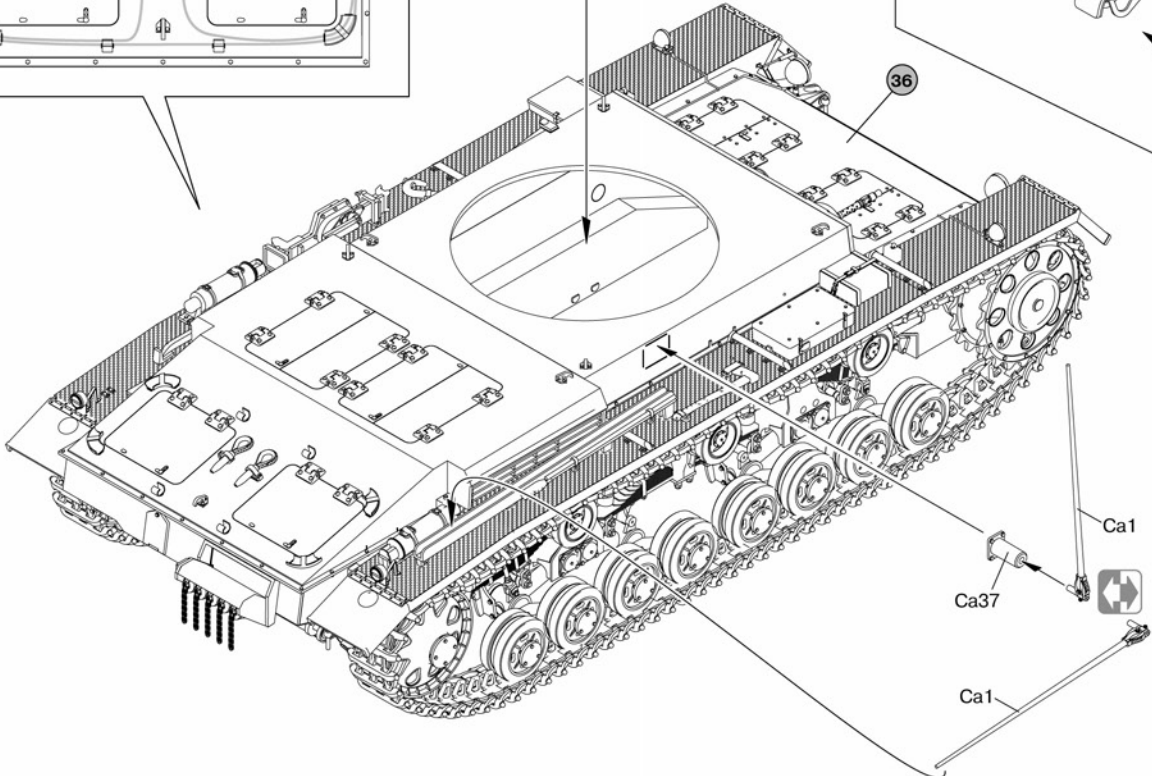
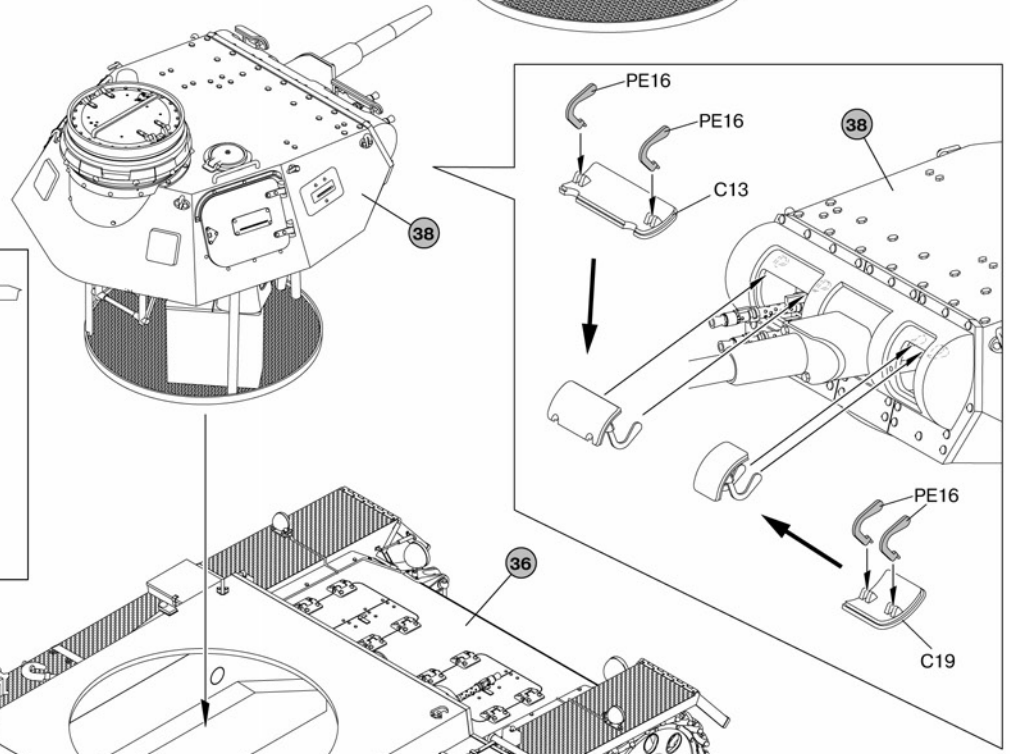
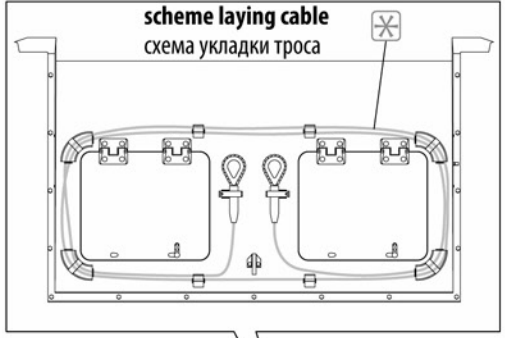
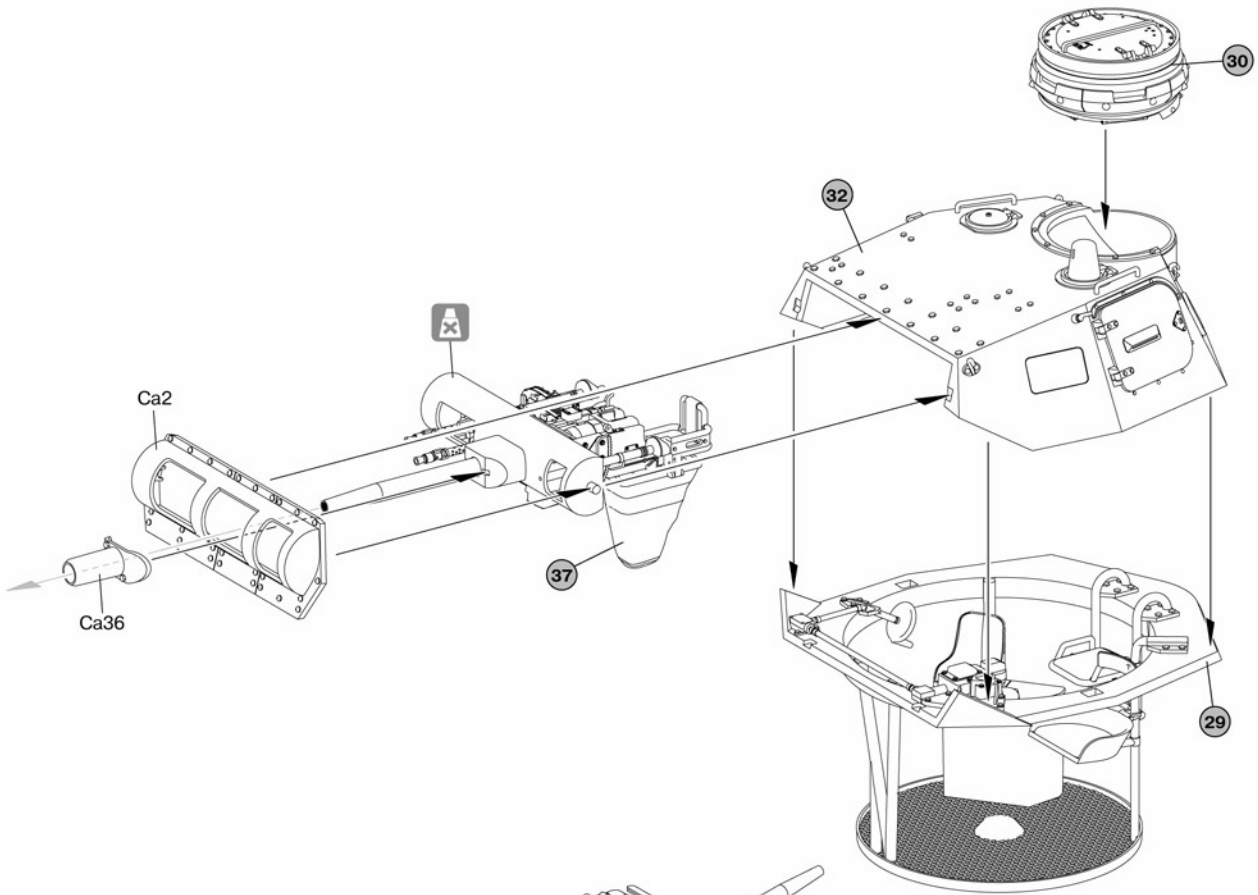

1 Pz. Kpfw. III Ausf. D tank from the unidentified units of the Wehrmacht, Germany, Winter 1939/1940 period.
Танк Pz. Kpfw. III Ausf. D из состава неустановленного подразделения вермахта, Германия, зима 1939/1940 годов.

MiniART : 35169

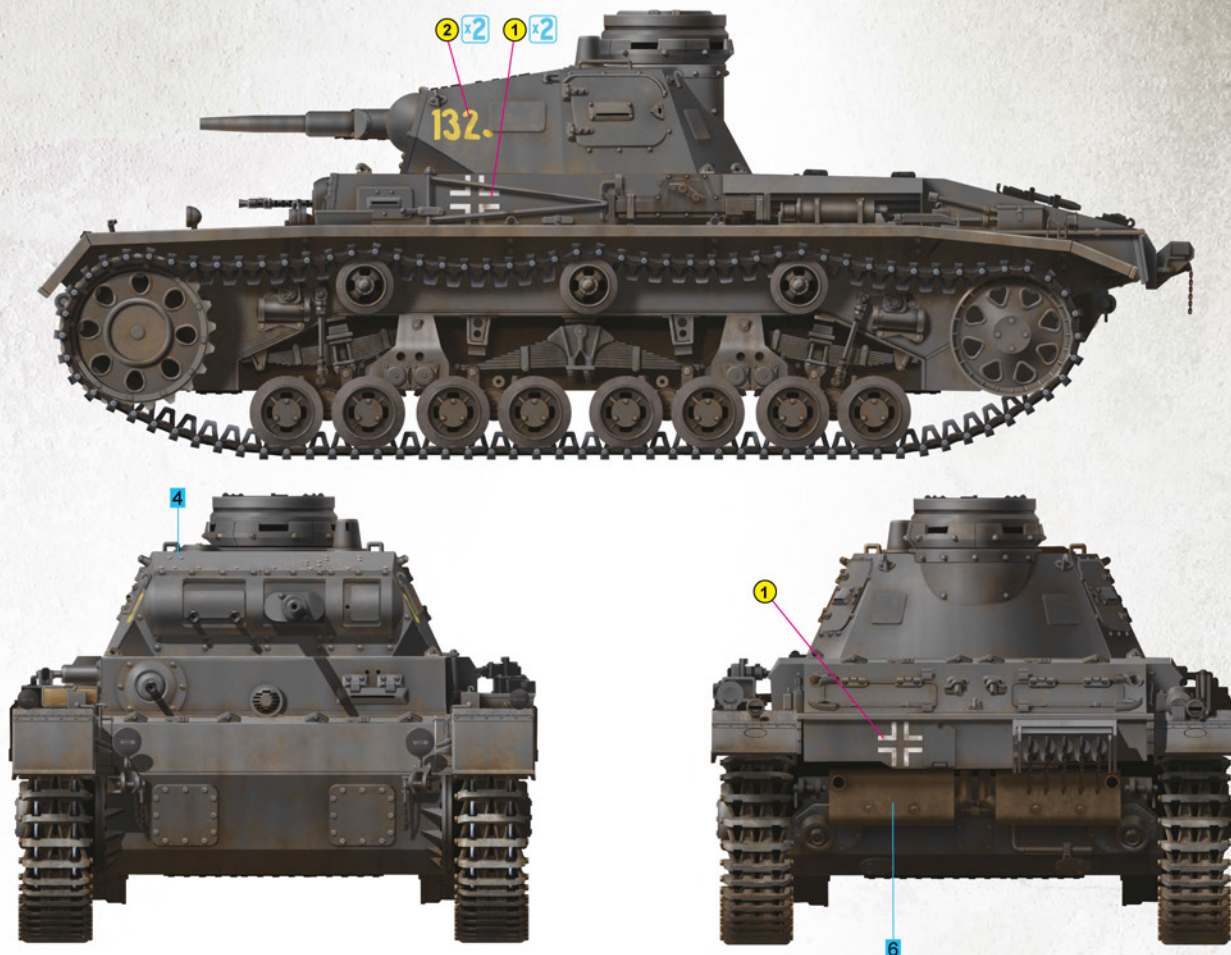

2 Pz. Kpfw. III Ausf. D tank from the unidentified training unit of the Wehrmacht, Germany, 1940-1941 years.
Танк Pz. Kpfw. III Ausf. D из состава неустановленного учебного подразделения вермахта, Германия, 1940-1941 годы.

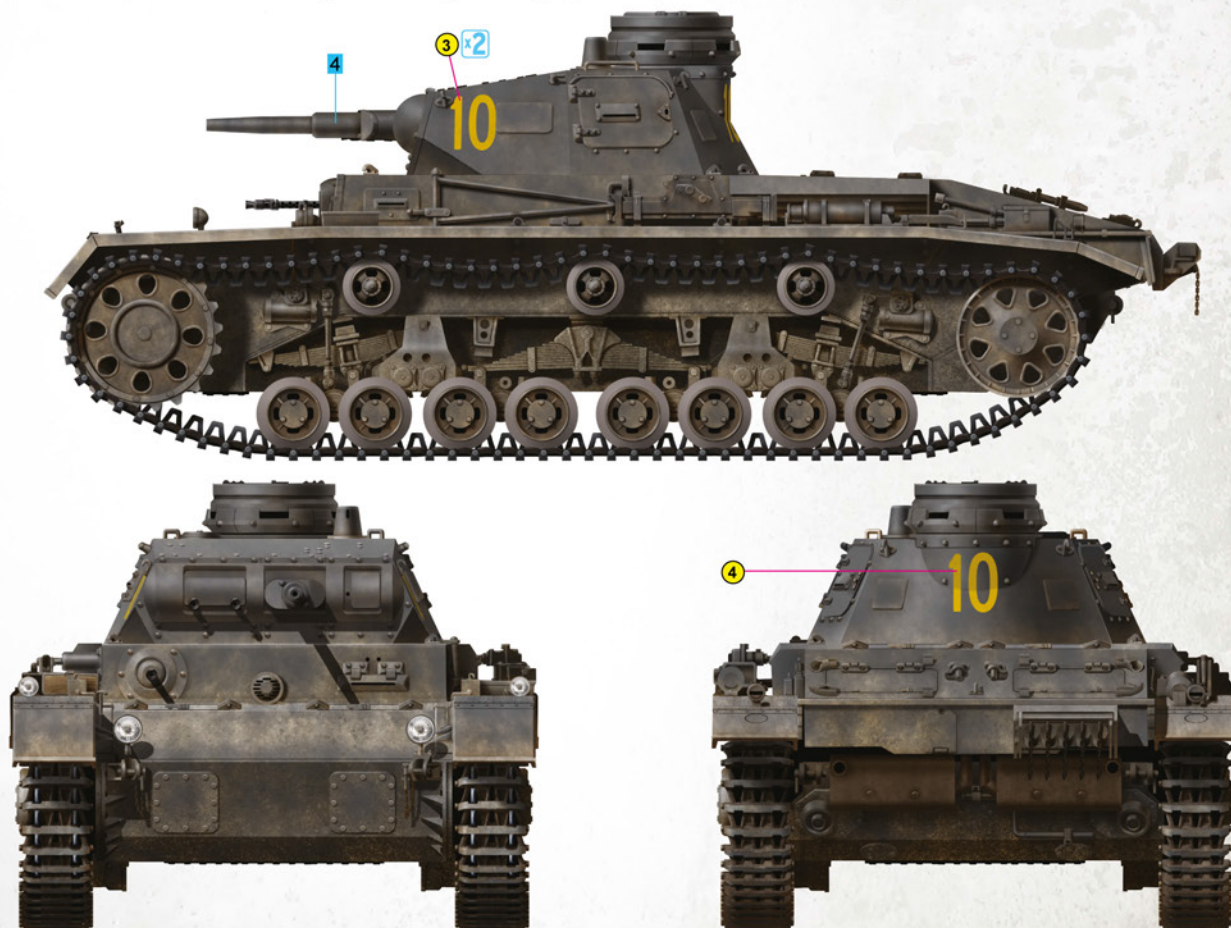

Chart colors for tank / Таблица цветов для окраски танка

Nr	Vallejo	TESTOR	TAMIYA	HUMBROL	REVELL	Mr. Color	Life Color	Color	Цвет
1	950	1749	XF1	33	8	33	LC02	Black	Черный
2	863	1405	X10	53	91	104	LC28	Gun Metal	Вороненый металл
3	825	1540	XF52	29	82	22	UA082	Dark Earth	Темно-коричневый

Yellow circle Decal number
Номер декали

Blue square Paint number
Номер краски

Red circle Variant of Painting
Вариант окраски

Nr	Vallejo	TESTOR	TAMIYA	HUMBROL	REVELL	Mr. Color	Life Color	Color	Цвет
4	995	1723	XF63	27	57	52	UA073	German Grey	Серый
5	951	1768	XF2	34	5	62	LC01	White	Белый
6	846	1785	XF68	113	83	81	LC32	Rust	Ржавчина

3 Pz. Kpfw. III Ausf. D tank from the 1st Battalion 1st Panzer Regiment 1st Panzer Division of the Wehrmacht, Poland, September 1939.
 Танк Pz. Kpfw. III Ausf. D из состава 1-го батальона 1-го танкового полка 1-й Танковой дивизии вермахта, Польша, сентябрь 1939 года.

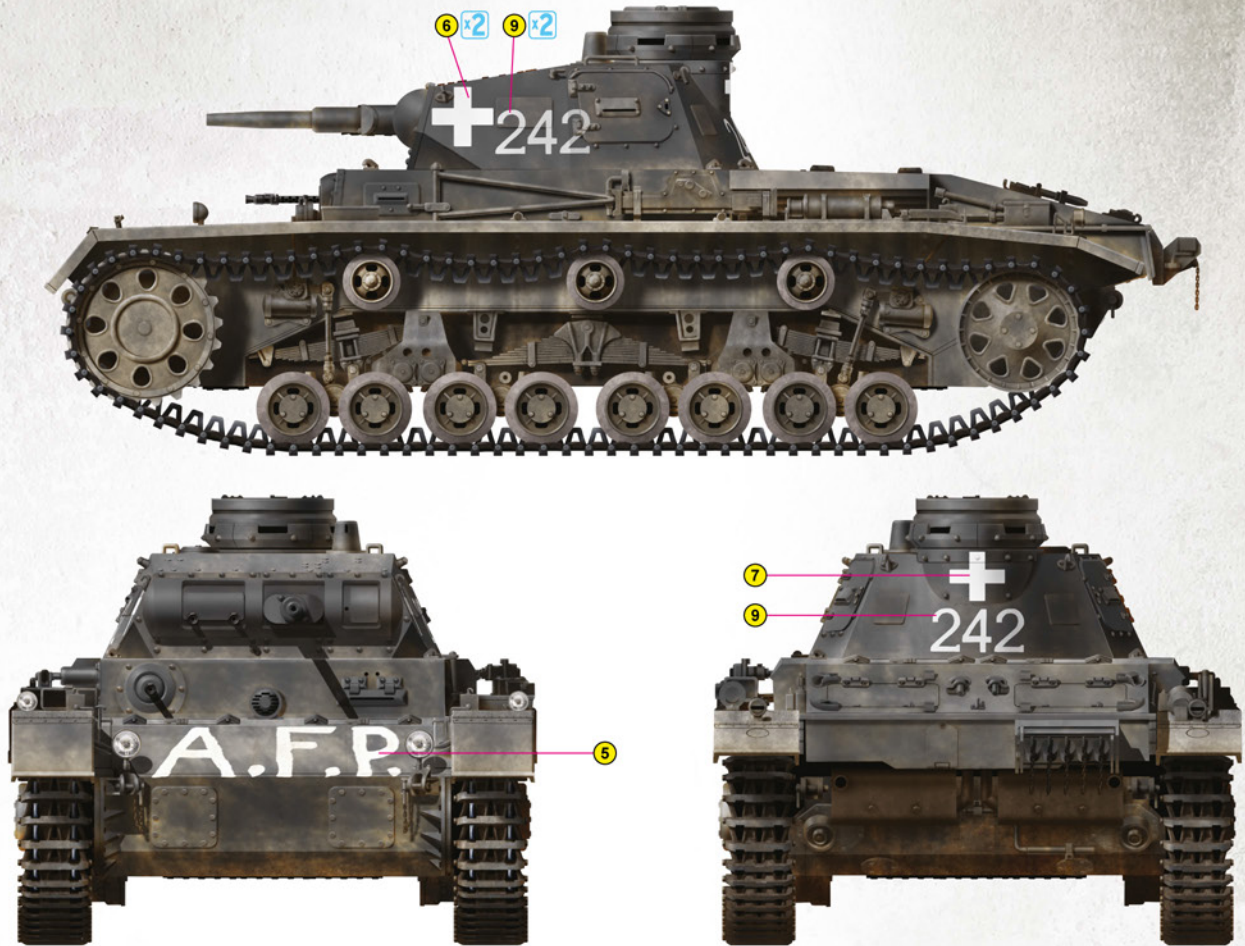

4 Pz. Kpfw. III Ausf. D (Fgst.Nr.60333) tank from the unidentified unit 1st Panzer Division of the Wehrmacht, Poland, September 1939.
 Танк Pz. Kpfw. III Ausf. D (серийный номер машины 60333) из неустановленного подразделения 1-й танковой дивизии вермахта, Польша, сентябрь 1939 года.

