

EN ATTENTION - Useful advice!

Study the instructions carefully prior to assembly. Remove parts from frame with a sharp knife or a pair of scissor and trim away excess plastic. Do not pull or parts. Assemble the parts in numerical sequence. Use plastic cement ONLY and use cement sparingly to avoid damaging the model. Black arrows indicate parts to be glued together. White arrows indicate on which frame the parts must be assembled WITHOUT using cement. These letters (A - B - C...) indicate on which frame the parts will be found. Paint small parts before detaching them from frame. Remove paint where parts are to be cemented. Crossed out parts must not be used.

IT ATTENZIONE - Consigli utili!

Prima di iniziare il montaggio studiare attentamente il disegno. Staccare con molta cura i pezzi dalle stampe, usando un taglio-balsa oppure un paio di forbici e tagliare con una piccola lima o con carta vetro fine eventuali sbavature. Mai staccare i pezzi con le mani. Montarli seguendo l'ordine delle numerazioni delle tavole. Eliminare dalla stampa il numero del pezzo appena montato facendogli sopra una croce. Le frecce nere indicano i pezzi da incollare, le frecce bianche indicano i pezzi da montare senza colla. Usare solo colla per polistirolo. Le lettere (A - B - C...) ai lati dei numeri indicano la stampa ove si trova il pezzo da montare. I pezzi sbarrati da una croce non sono da utilizzare.

DE ACHTUNG - Ein nützlicher Ratt!

Vor der Montage die Zeichnung aufmerksam studieren. Die einzelnen Montageteile mit einem Messer oder einer Schere vom Spritzing sorgfältig entfernen. Eventuelle Grate werden mit einer Klinge oder feinem Schmirgelpapier beseitigt. Keinesfalls die Montageteile mit den Händen entfernen. Bei der Montage der Teileummernung folgen. Pfeile zeigen die zu klebenden Teile während die weissen Pfeile die ohne Leim zu montierenden Teile anzeigen. Bitte nur Plastikklebstoff verwenden. Die Buchstaben (A - B - C...) neben den Nummern zeigen auf welchem Spritzring der zu montierende Teil zu finden ist. Die mit einem Kreuz markierten Teile sind nicht zu verwenden.

FR ATTENTION - Conseils utiles!

Avant de commencer le montage, étudier attentivement le dessin. Détacher avec beaucoup de soin les morceaux des moules en usant un massicot ou bien un pair de ciseaux et couper avec une petite lame avec de papier de verre fin ébarbages éventuels. Arrêter de détacher les morceaux avec le main. Monter les en suivant l'ordre de la numération des tables. Éliminer de la moule le numéro de la pièce qui vient d'être montée, en le biffant avec une croix. Les flèches noires indiquent les pièces à coller, les flèches blanches indiquent les pièces à monter sans colle. Employer seulement de la colle pour polystyrol. Les lettres (A - B - C...) aux côtés des numéres indiquent la moule où se trouve la pièces à monter. Les pièces marquées par une croix ne sont pas à utiliser.

NL OPGELET - Belangrijke bemerkingen!

Bestudeer zorgvuldig het montageplan voor het bouwen. Breek nooit onderdelen van het kader. Maak ze los met een scherp mes of kleine tangtang. Verwijder daarna al het overtollige plastic en pas de delen afvoeren te lijmen. Gebruik alleen lijm voor plastic modellen. Werk zorgvuldig en spaarzaam, teveel lijm zal uw model beschadigen. Zwarte pijlen duiden de te lijmen delen aan. Witte pijlen verwijzen naar bewegende delen welke niet mogen worden gelijmd. Deze letters (A - B - C...) geven de kaders aan waarin de onderdelen zich bevinden. Schilder de kleine onderdelen voor ze van het kader te snijden. Verwijder de verf van de te lijmen oppervlakten.

ES ATENCION - Consejos útiles!

Estudiar las instrucciones cuidadosamente antes de comenzar el montaje. Separar las piezas de las bandejas con un cuchillo afilado o un par de tijeras y retirar el exceso de plástico o rebaba. No arrancar las piezas. Montar las piezas en orden numérico. Utilizar SOLAMENTE pegamento para plástico y en poca cantidad para evitar que se dane el modelo. Las flechas negras indican las piezas que se deben pegar juntas. Las flechas blancas indican las piezas que deben ensamblarse SIN usar pegamento. Las letras (A - B - C...) indican en que bandeja se encuentran las piezas. Pintar las piezas pequeñas antes de separarlas de la bandeja. Retirar la pintura de los lugares por donde se deban pegar las piezas.

A

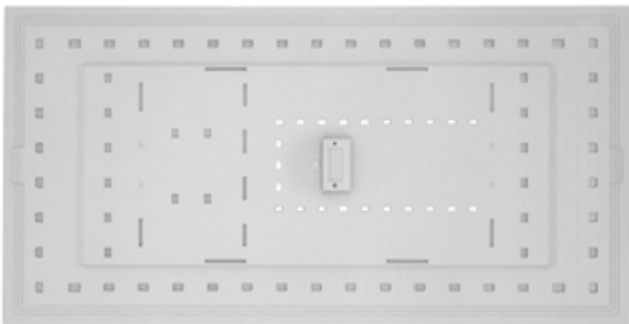

Aprire i fori
Drill holes
Ouvrir les trous
Die Locher Aushohren
Perforar los agujeros
Open gaten



Separare
Cut
Retirer
Entfernen
Separar
Gesneden

B
4x

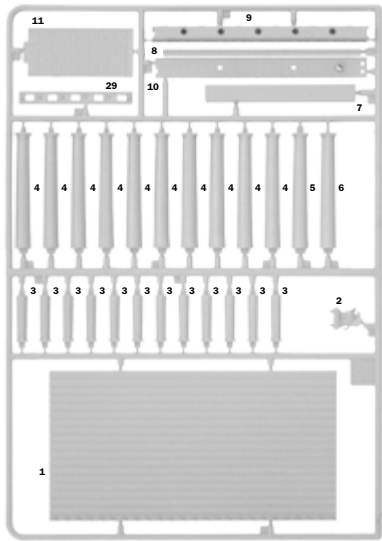

C
4x

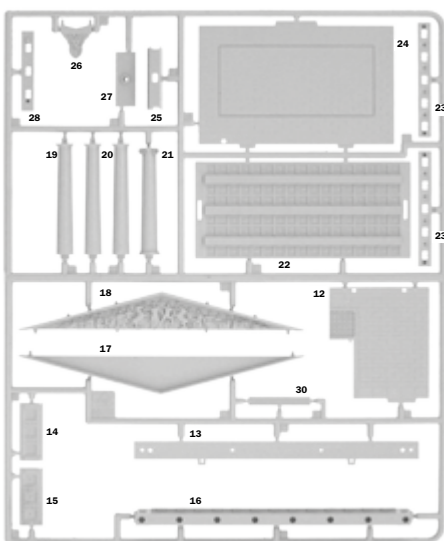

D

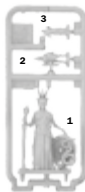

1

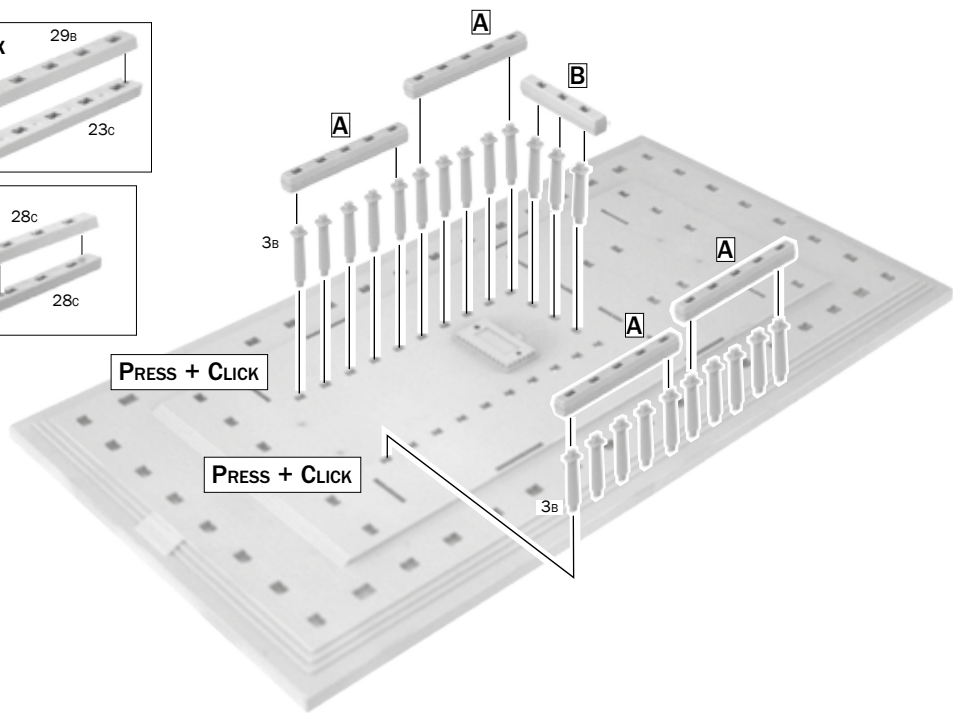
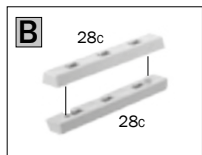
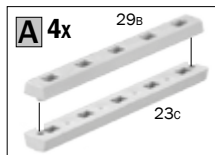

2

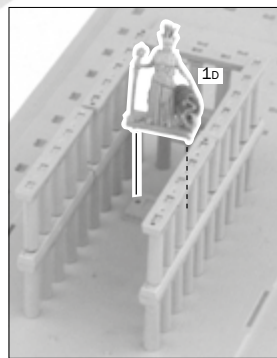
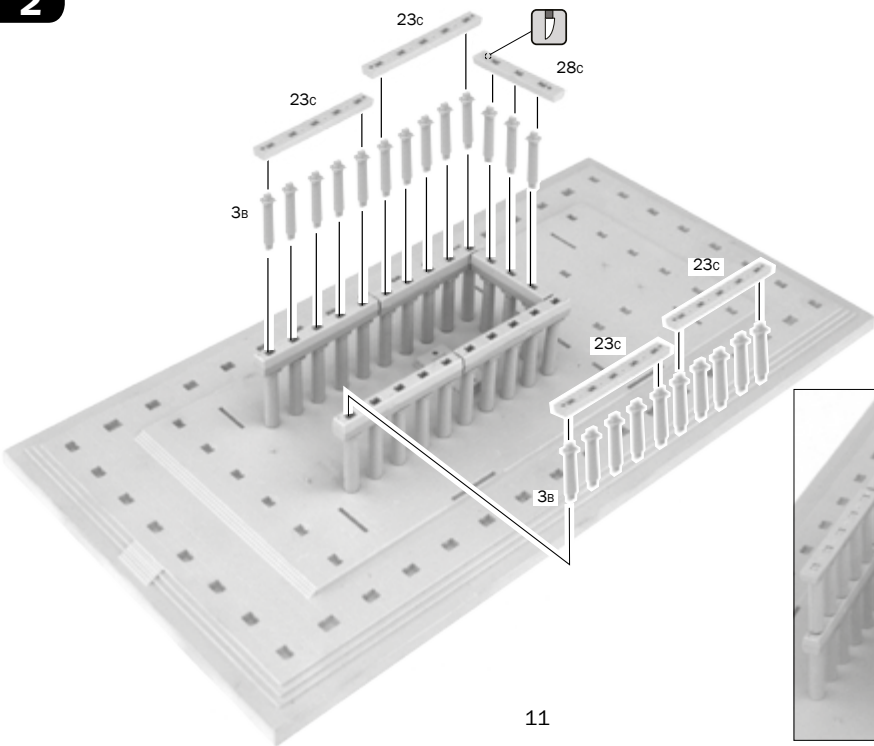

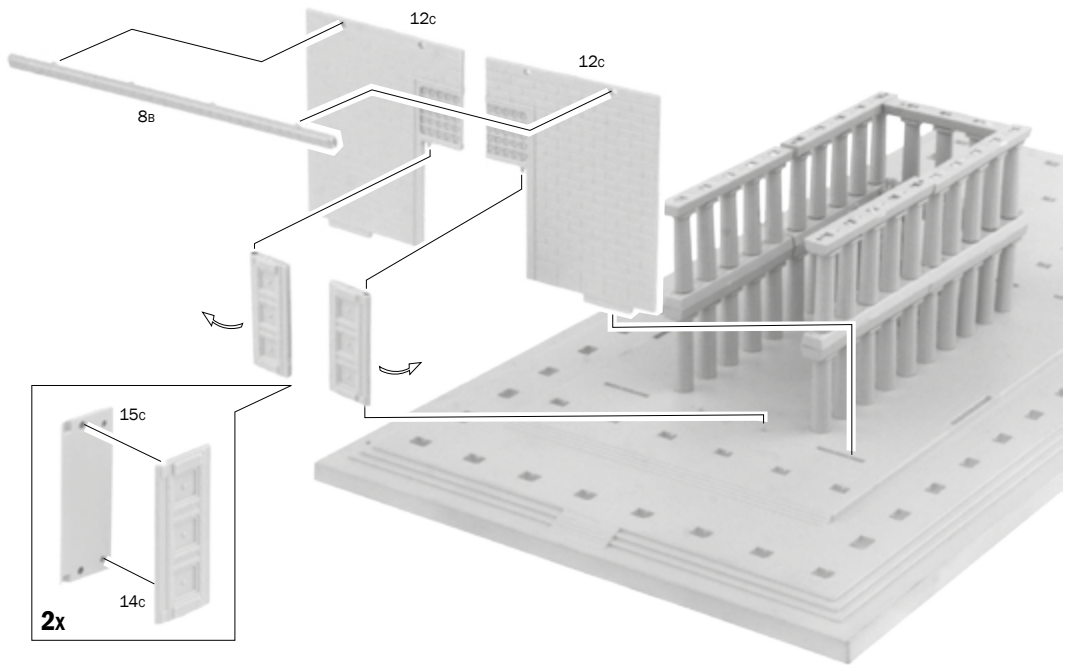
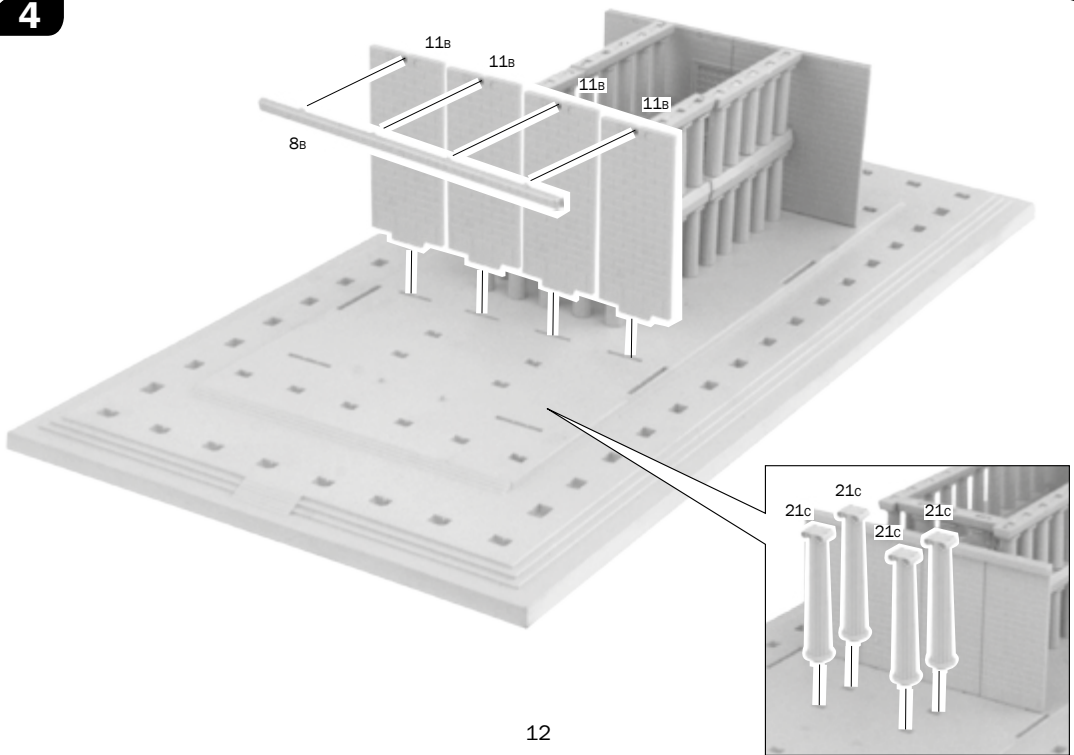
3**4**

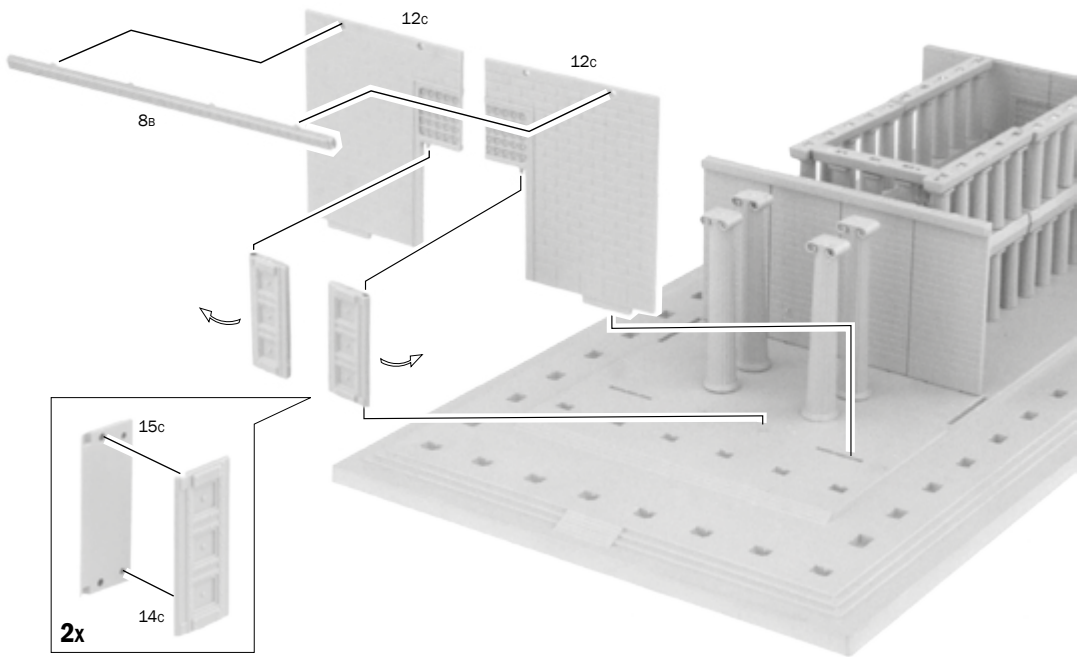
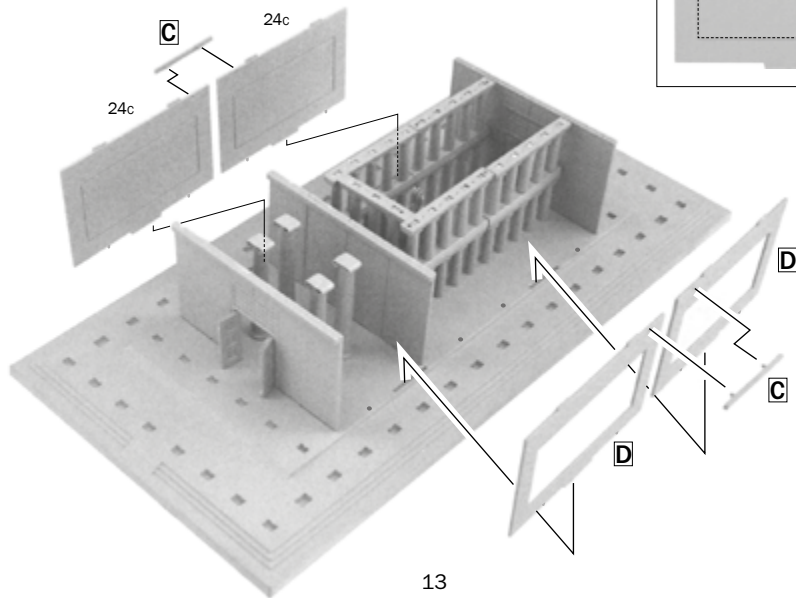
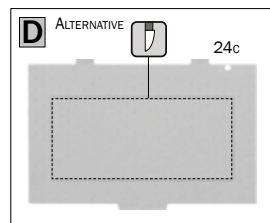
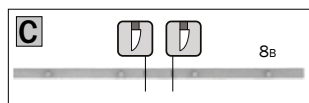
5**6**

13

7

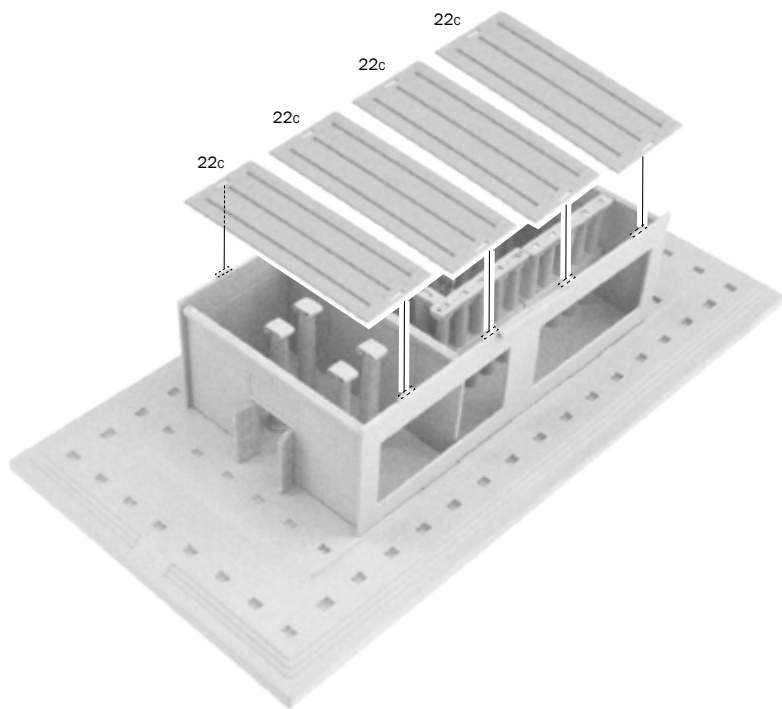

8

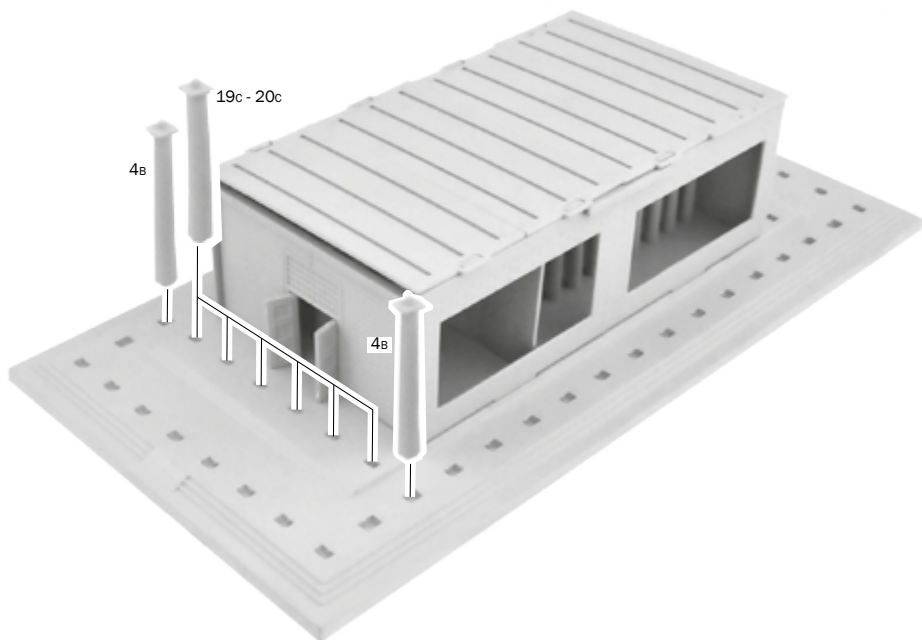

9

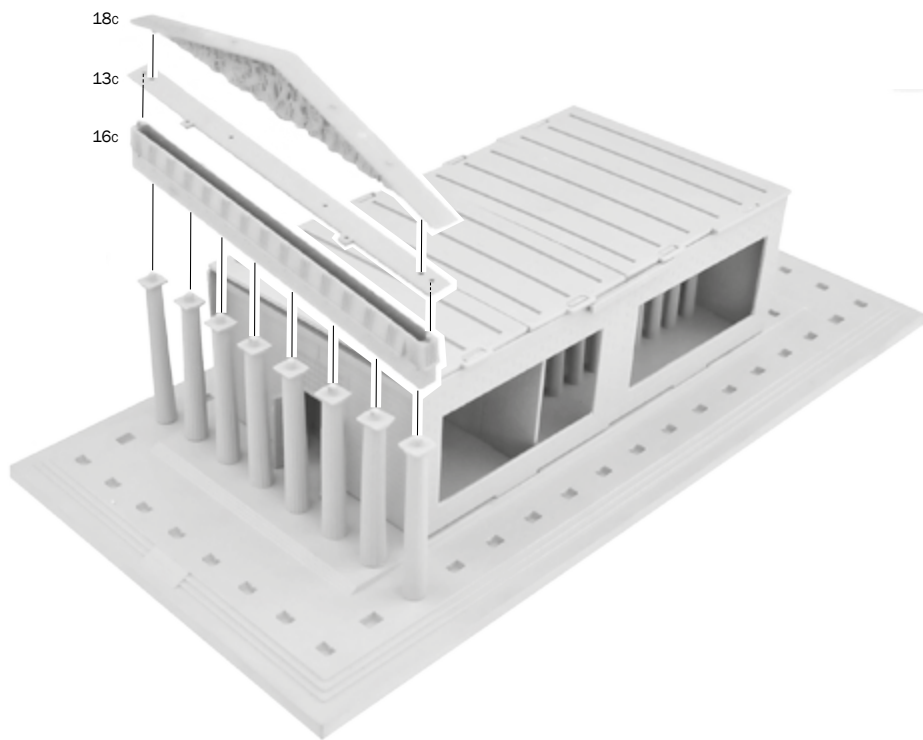

10

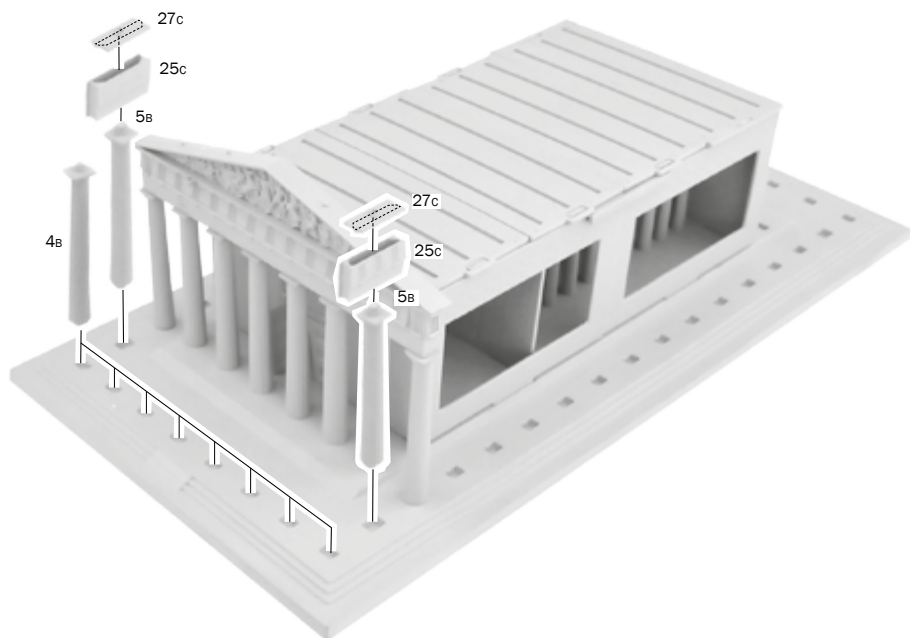

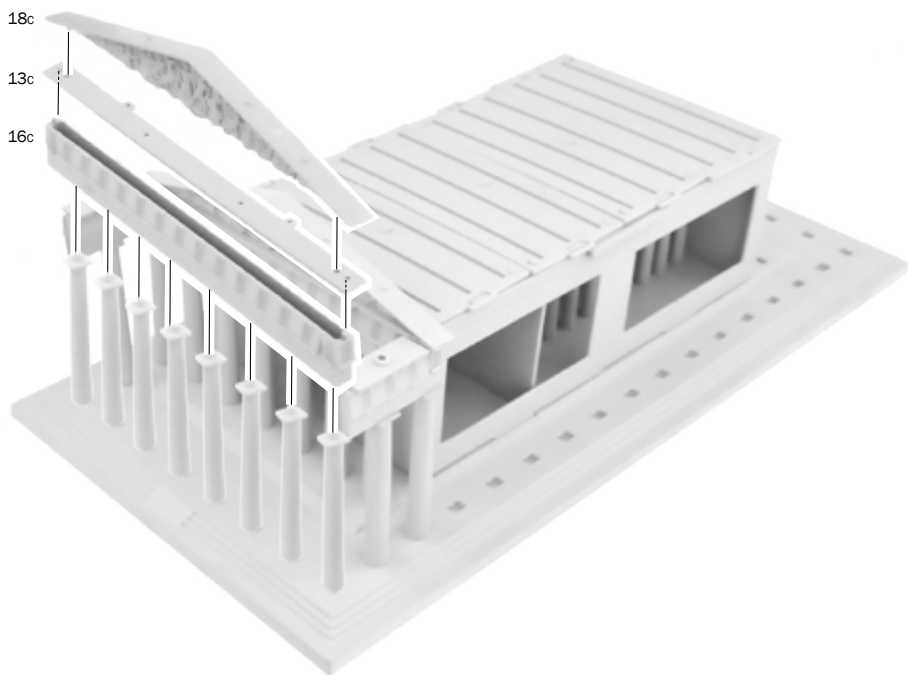
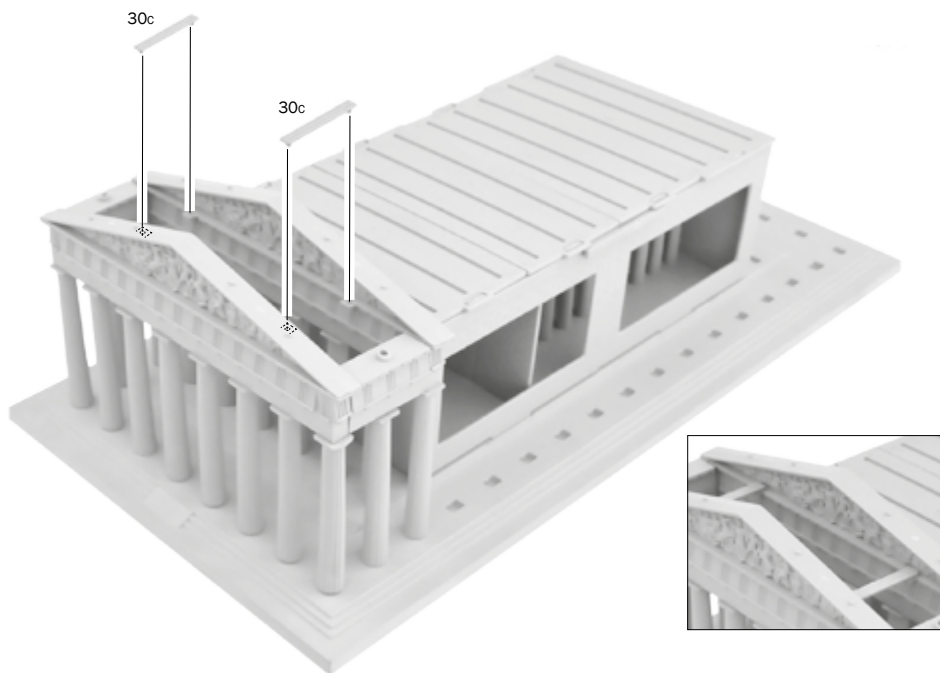
11**12**

13

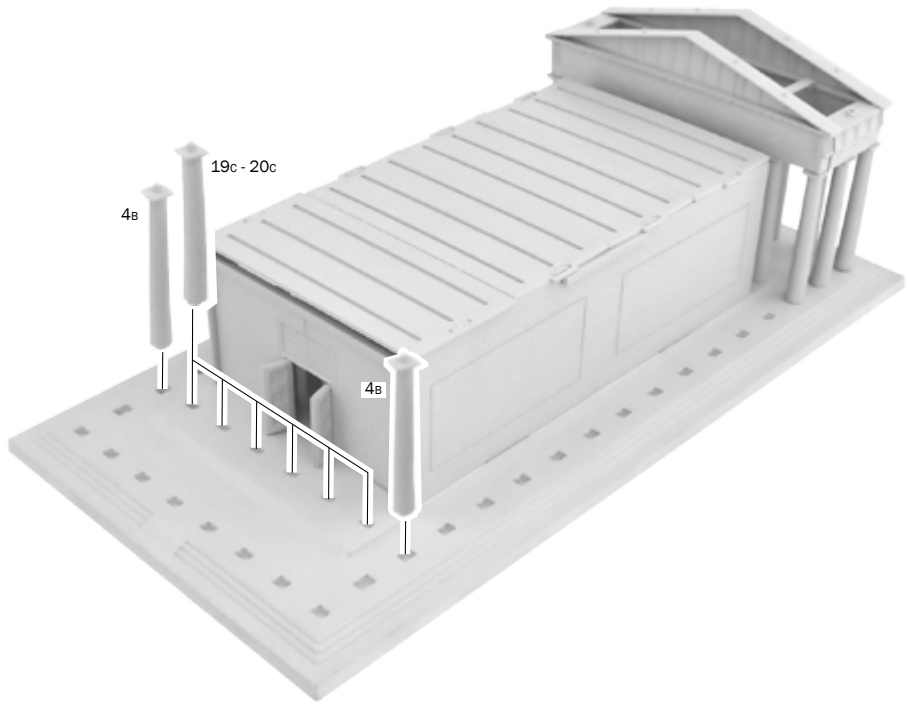

14

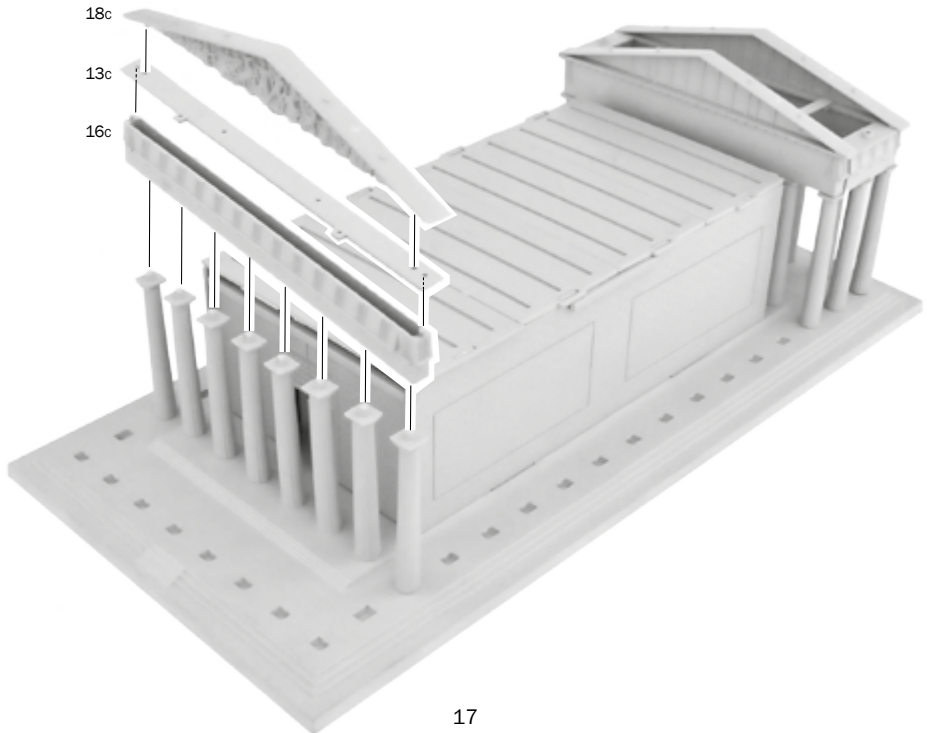

15

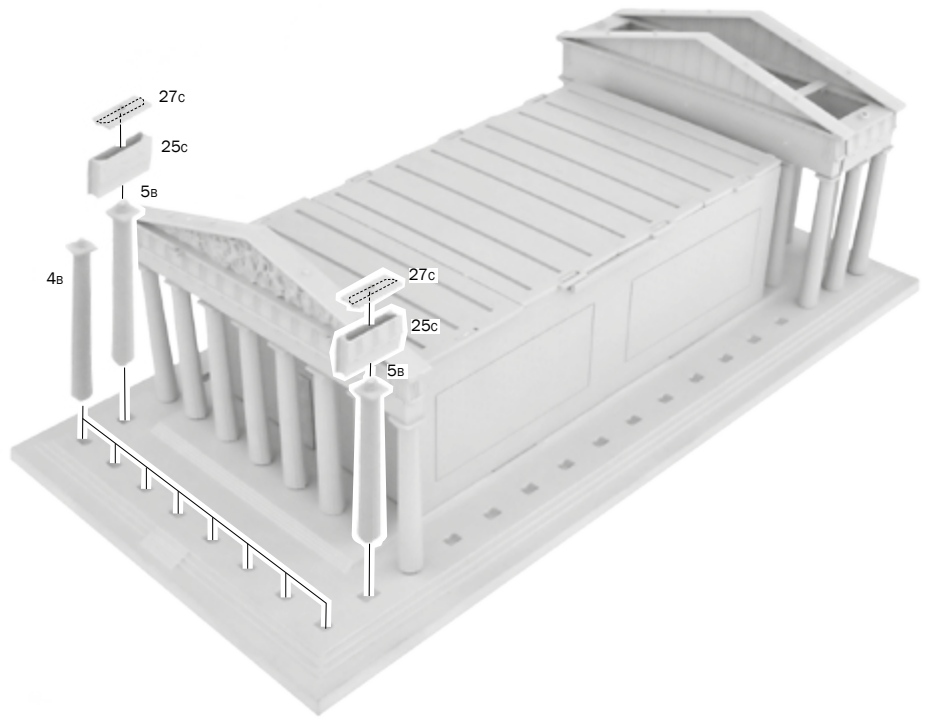

16

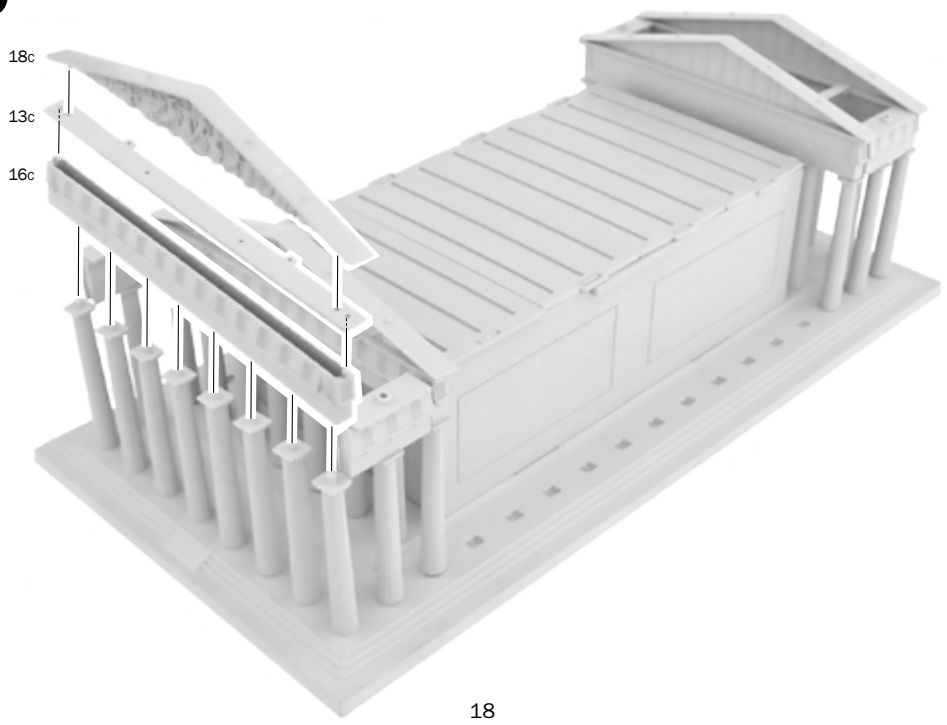

17

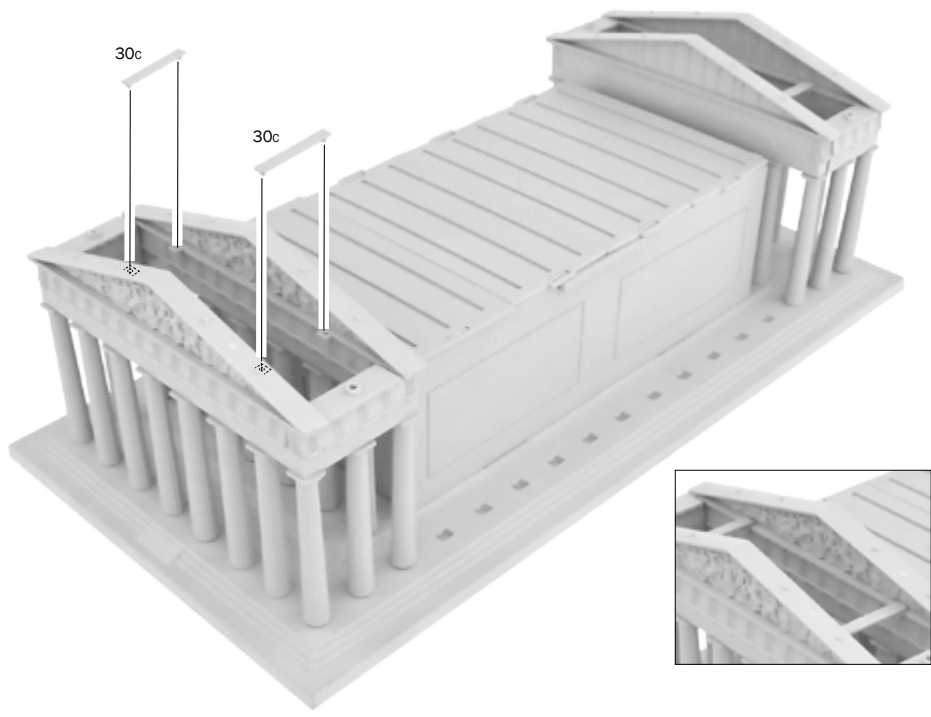

18

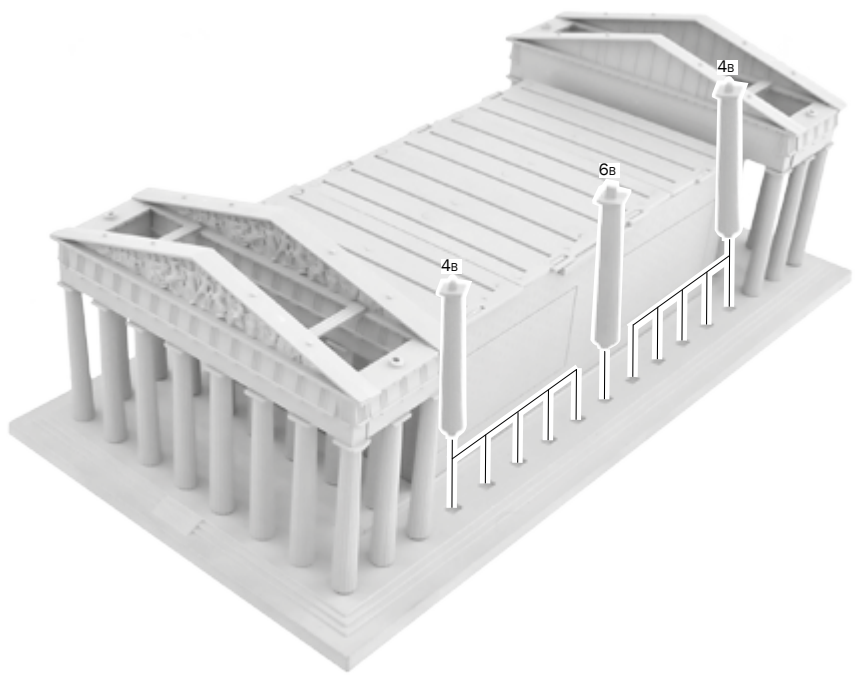

19

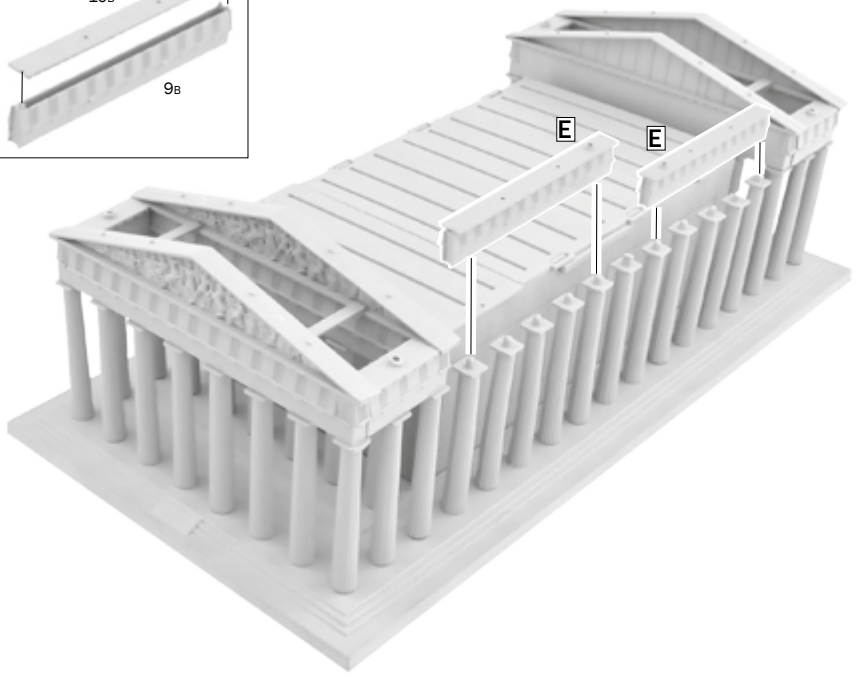
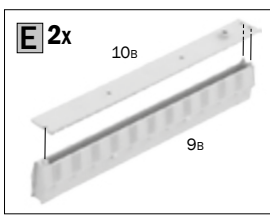

20

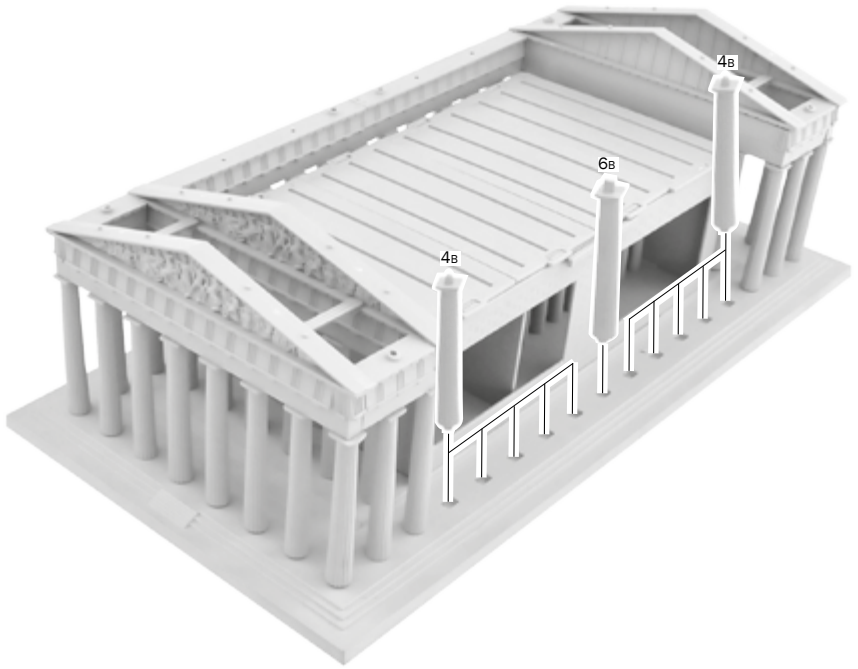

21

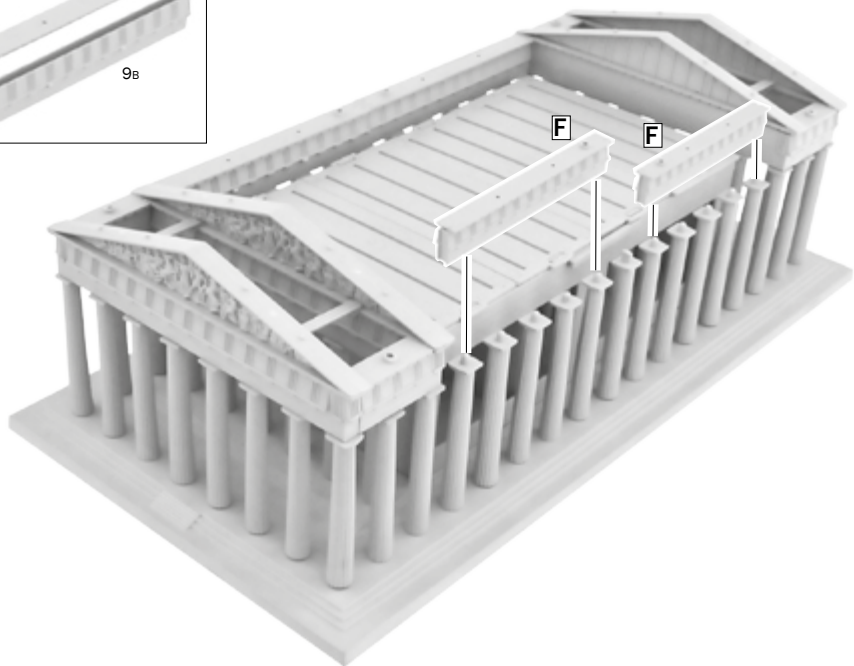
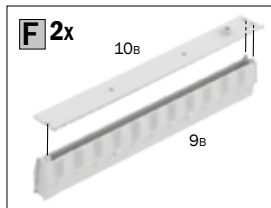

22

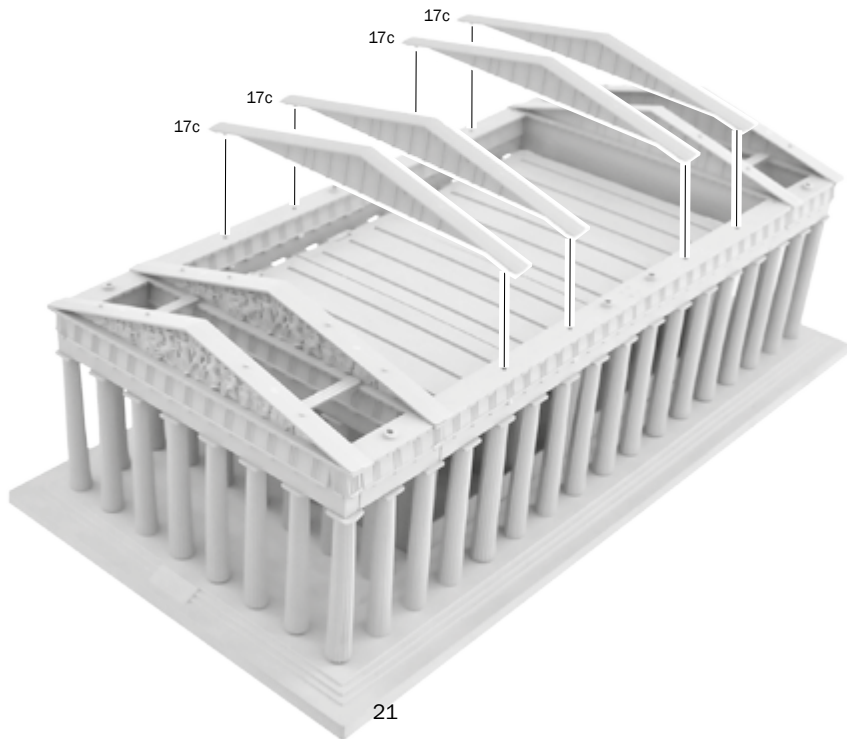

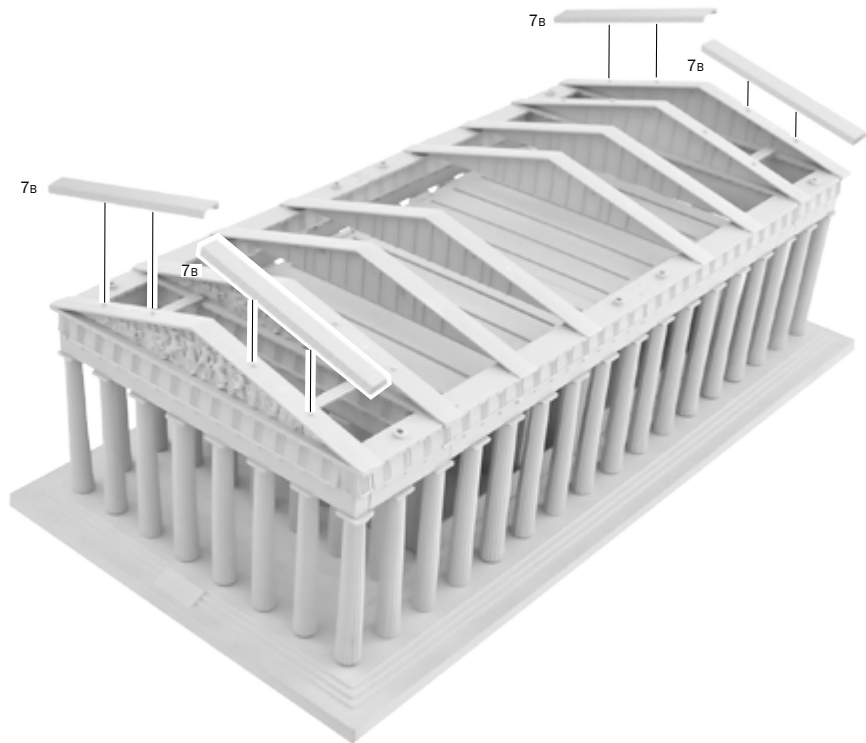
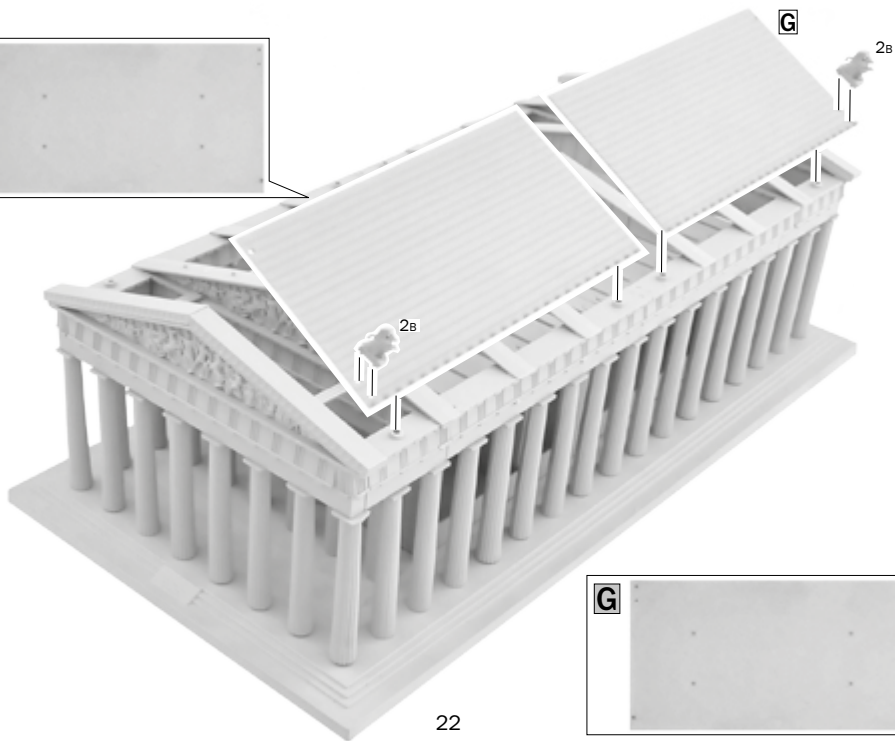
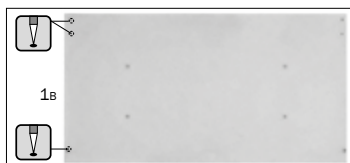
23**24**

25

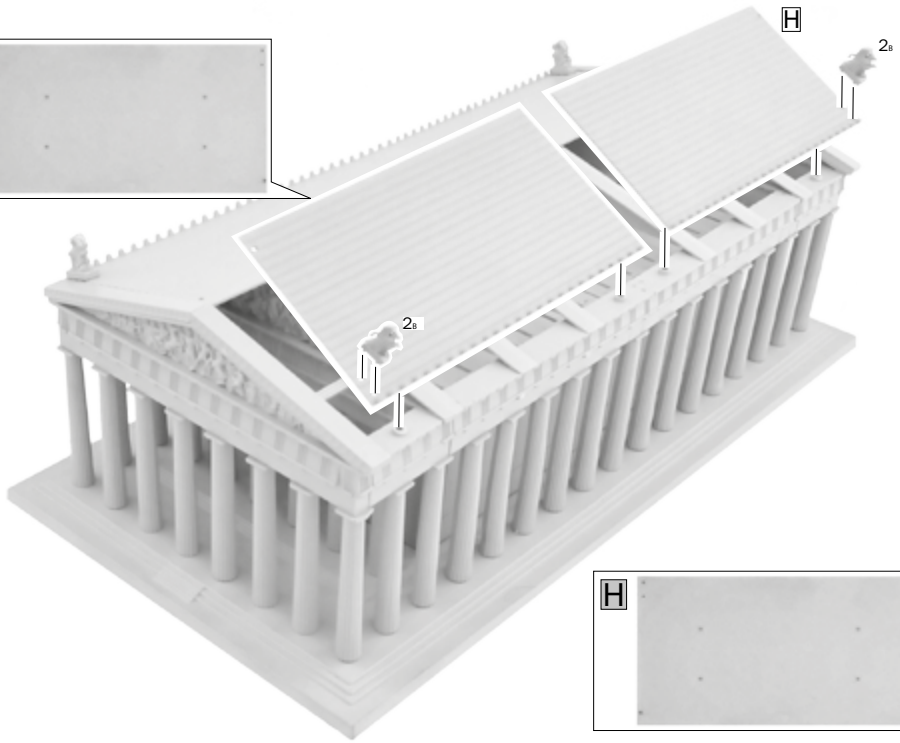

26

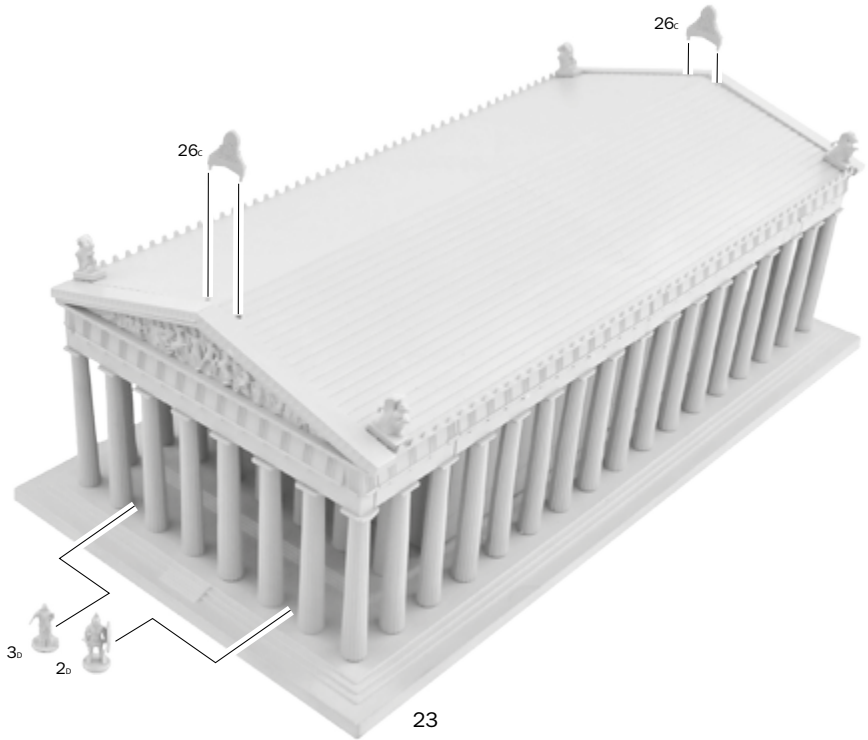

Interni:

Pavimenti in marmo,
Colonne e porticato
Portoni dorati
Statua di Atena

Interiors

Marble floors
Columns and internal arcade
Golden doors
Statue of Athena

 **Metal Gloss Gold**
4671AP

 **Marmo Pentelico** Colori di riferimento nella scheda
Pentelic Marble Color Reference tab

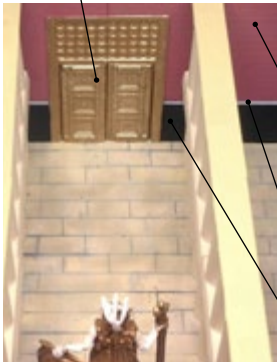
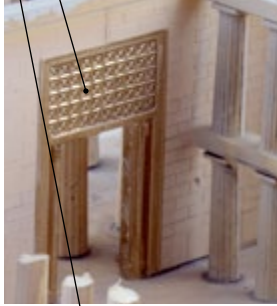

 **Flat Guards Red**
4632AP

 **Flat White**
4603AP

 **Flat Black**
4768AP

 **Metal Gloss Gold**
4671AP

 **Flat White**
4603AP



Il marmo Pentelico

è di un bianco impeccabile
con una uniforme,
debole colorazione gialla

The Pentelic marble

is an impeccable white
with uniform, weak
yellow colouration

 **Flat Skin tone Warm Tint**
4603AP

 **Flat Light Flesh**
4769AP

 **Flat White**
4603AP





Flat White
4603AP

Flat Skin tone Warm Tint
4603AP

Flat Light Flesh
4769AP



Il frontone orientale e occidentale
i colori da usare

Flat Black
4768AP

Gloss (Blue Angels Blue)
4687AP

Flat Earth Red
4707AP

Flat Light Flesh
4769AP

The eastern and western pediments
the colors you need

Flat Orange
4603AP

Gloss Light Blue
4650AP

Flat Skin tone Warm Tint
4603AP

Flat White
4603AP



Flat Guards Red
4632AP

Metal Gloss Gold
4671AP

Flat White
4603AP

Flat Black
4768AP





Flat White
4603AP

Flat Guards Red
4632AP

Gloss Light Blue
4650AP

Flat Orange
4603AP

Flat White
4603AP



Il tetto
Arancione
mixato
con una punta
di bianco e
ombreggiatura
nera

The roof
orange mixed
with a tip
of white and
black shading



Flat Guards Red
4632AP



Flat White
4603AP



Flat Black
4768AP

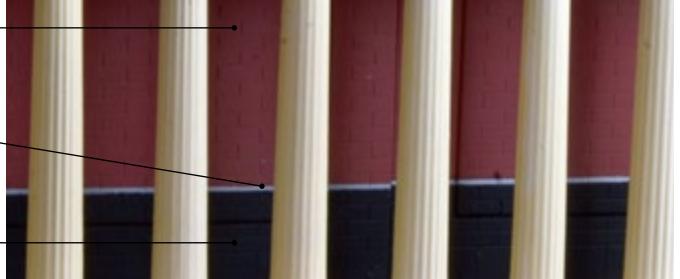

Usate le illustrazioni
come riferimento
per colorare le due
figure esterne

Use illustrations
as a reference
for coloring the two
external figures

