



Italeri S.p.A
Via Pradazzo, 6/b
40012 Calderara di Reno
Bologna - Italy
www.italeri.com

Conservare
il presente indirizzo
per future reference
Retain this address
for future reference

WARNING

Before starting to assemble the model, carefully examine the various assembly phases indicated in the drawings. A) Carefully remove the parts from the sprues using a razor blade or emery paper. B) Eliminate any burrs, check the fit of each piece before cementing in place. Before assembly, paint any internal parts of the model or parts which are difficult to get at once assembly has been made. Black arrows indicate parts to be glued together White arrows indicate that parts must be assembled without using cement.

IMPORTANTE

Prima di iniziare il montaggio del modello studiare attentamente le varie fasi d'assemblaggio indicate nei disegni. A) Staccare con cura le parti dalle stampette. B) Eliminare con una limetta o con una carta-vetro fine le eventuali sbavature, controllare l'incastro di ogni pezzo prima di incollarlo. Verniciare, prima di assemblare, gli eventuali particolari interni del modello o le parti difficilmente raggiungibili ad assemblaggio effettuato. Le frecce nere indicano i pezzi da incollare Le frecce bianche indicano i pezzi da montare senza colla.

IMPORTANTE

Antes de empezar el montaje del modelo, estudiándose cuidadosamente las varias fases de ensamblaje indicada en los dibujos. A) Despegar con cuidado las partes. B) Eliminar con una pequeña lima o con papel de lija las eventuales rebabas, verifique que cada pieza encaje bien antes de pegar en posición. Barnizar, antes de ensamblar, los eventuales detalles internos del modelo o las partes difícilmente alcanzables después de efectuado el ensamblaje. Las flechas negras indican las piezas que se deben pegar juntas Las flechas blancas indican las piezas que deben ensamblarse sin usar pegamento.

BELANGRIJK

Voor met eigenlijke montage te beginnen eerst de diverse montagefasen zoals die in de tekeningen zijn aangegeven aandachtig doorlezen. A) De delen voorzichtig uit de platen halen. B) Eventuele onreinheden met een vijl of fijn schuurpapier wegwerken, controleer de passing van elk deel vóór het lijmen. Voor een en ander in elkaar te zetten eerst die delen die zich aan de binnekant bevinden of die wanneer het model in elkaar gezet is moeilijk bereikbaar zullen zijn, vernis. Die schwarzen Pfeile zeigen die zu klebenden Teile während Die weissen Pfeile die ohne leim zu montierenden Teile anzeigen.

WICHTIG

Vor der Montage des Modells Aufmerksam die Verschiedenen Phasen der auf den Zeichnungen Angegebenen Zusammensetzung Beachten und Durchlesen. A) Sorgfältig die Einzelnen Teile Abnehmen. B) Mit einer Kleinen Feile oder mit Sandpapier Eventuelle Unregelmäßigkeiten Beseitigen, die Teile vor dem Verkleben ungeleimt zusammenhalten, um ihren Passitz zu prüfen. Vor der Zusammensetzung Eventuelle Innere Teile, die nach der Zusammensetzung Schlecht zu Erreichen sind, Lacken. Die schwarzen Pfeile zeigen die zu klebenden Teile während Die weissen Pfeile die ohne leim zu montierenden Teile anzeigen.

IMPORTANT

Avant de procéder au montage du modèle, étudier attentivement les différentes phases d'assemblage indiquées sur le dessin. A) Détacher avec soin les pièces des montants. B) Eliminer avec une petite lime ou avec du papier de verre à grain fin les bavures éventuelles, contrôler que chaque pièce soit bien conforme avant de la coller à sa place. Peindre, avant de les assembler les éventuels détails internes du modèle ou les pièces difficiles à atteindre une fois l'assemblage effectué. Les fleches noires indiquent les pièces à coller Les fleches blanches indiquent les pièces à monter sans colle.

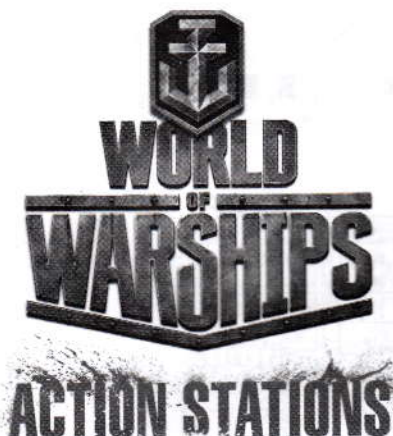
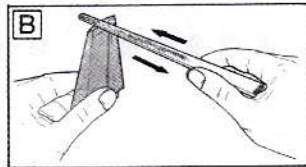
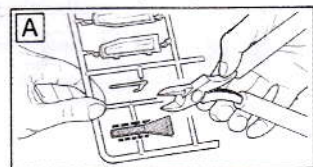

AIRCRAFT CARRIER → USA USS ESSEX 1:700 SCALE

Upper hull



Lower hull



Waterline plate



Stern hangar deck

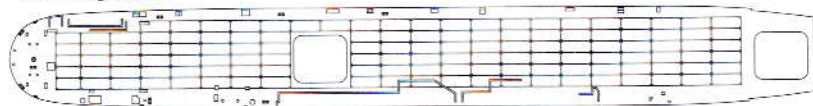

Fore hangar deck



Fore flight deck



Aft flight deck

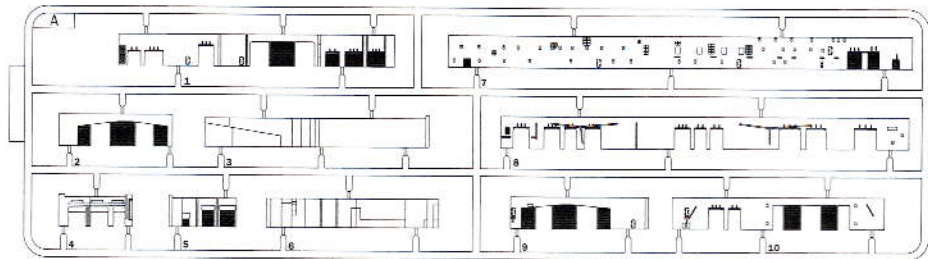
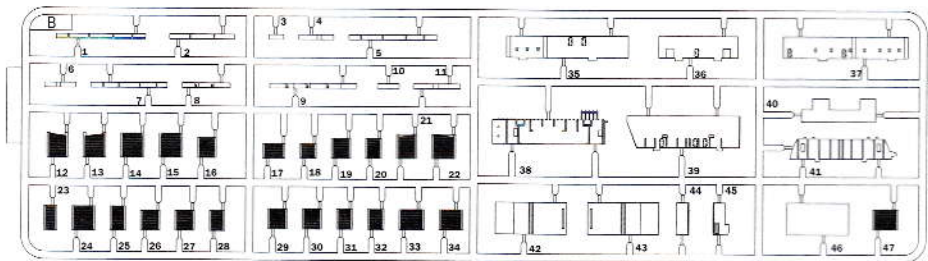
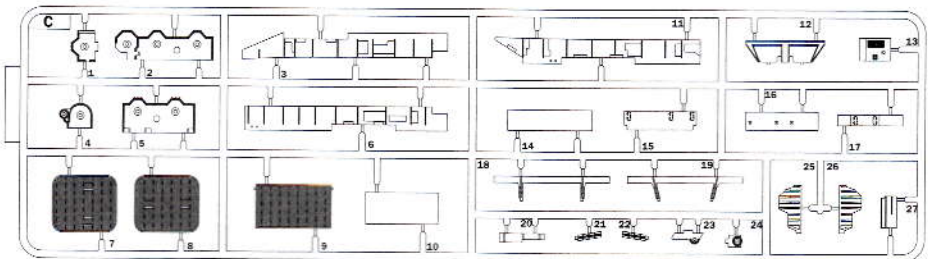
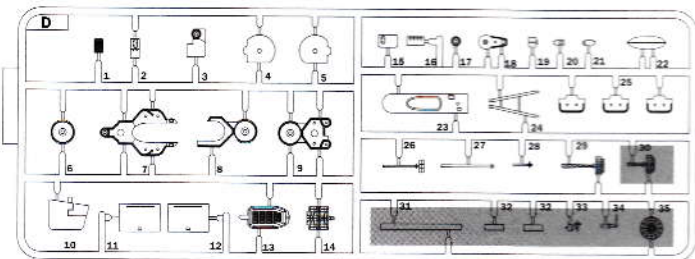
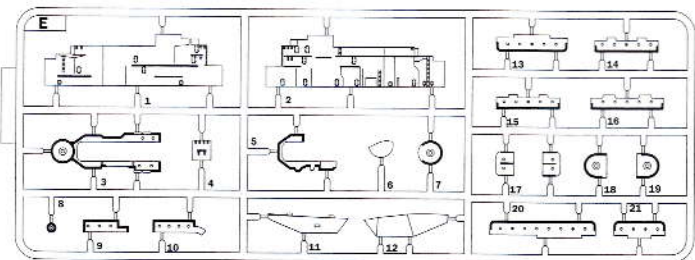
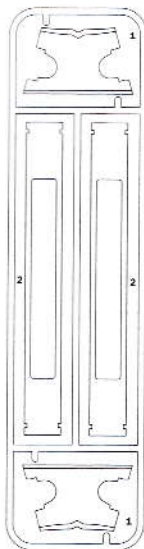

A**B****C****D****E****F**

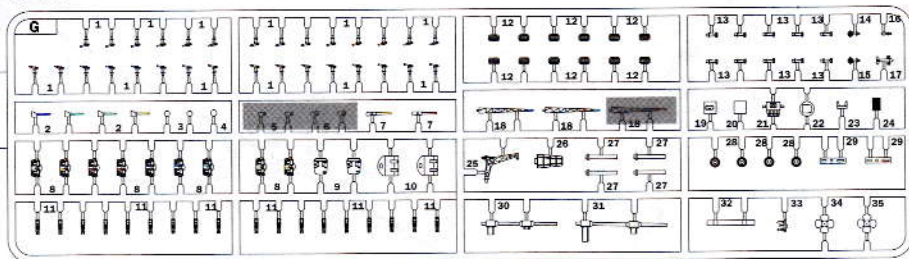
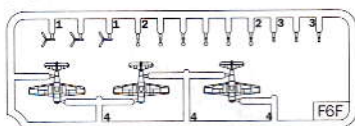
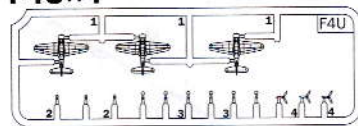
Gx2**F6Fx4****F4Ux4**

Aprire i fori
Drill holes
Ouvrir les trous
Die Locher Ausbohren
Perforar los agujeros
Open gaten

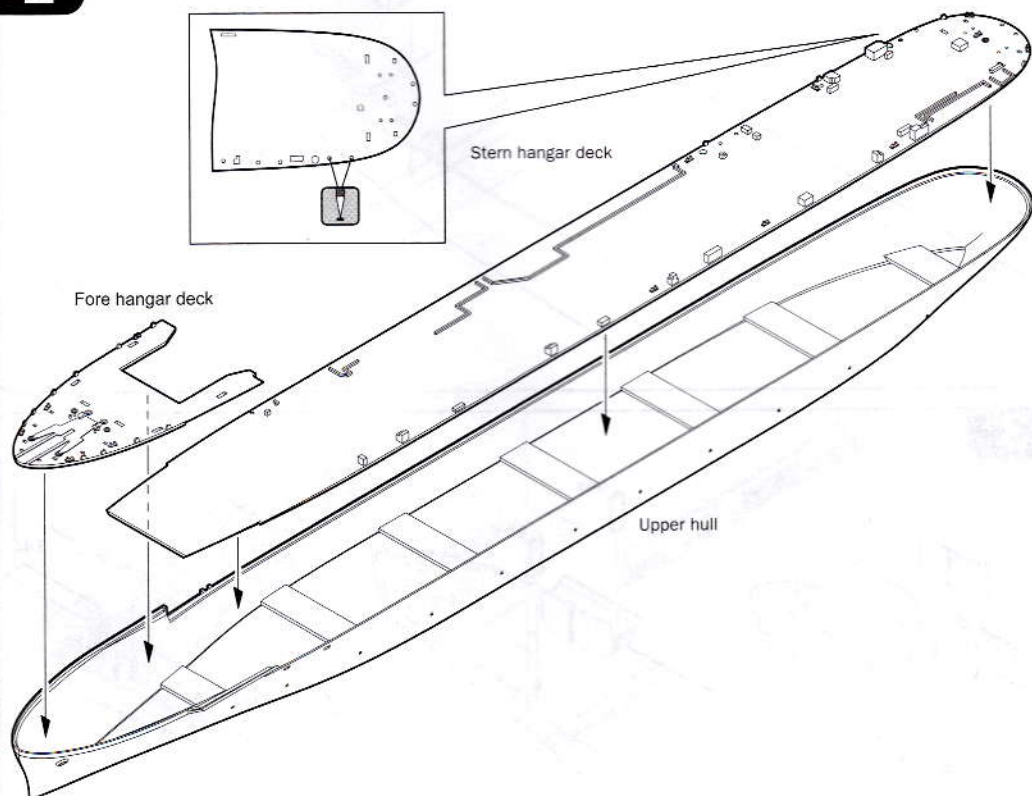

Parti da non utilizzare
Parts not for use
Pièces à ne pas utiliser
Telle werden nicht verwenden
Partes a no utilizar
Onderdelen niet te gebruiken

1

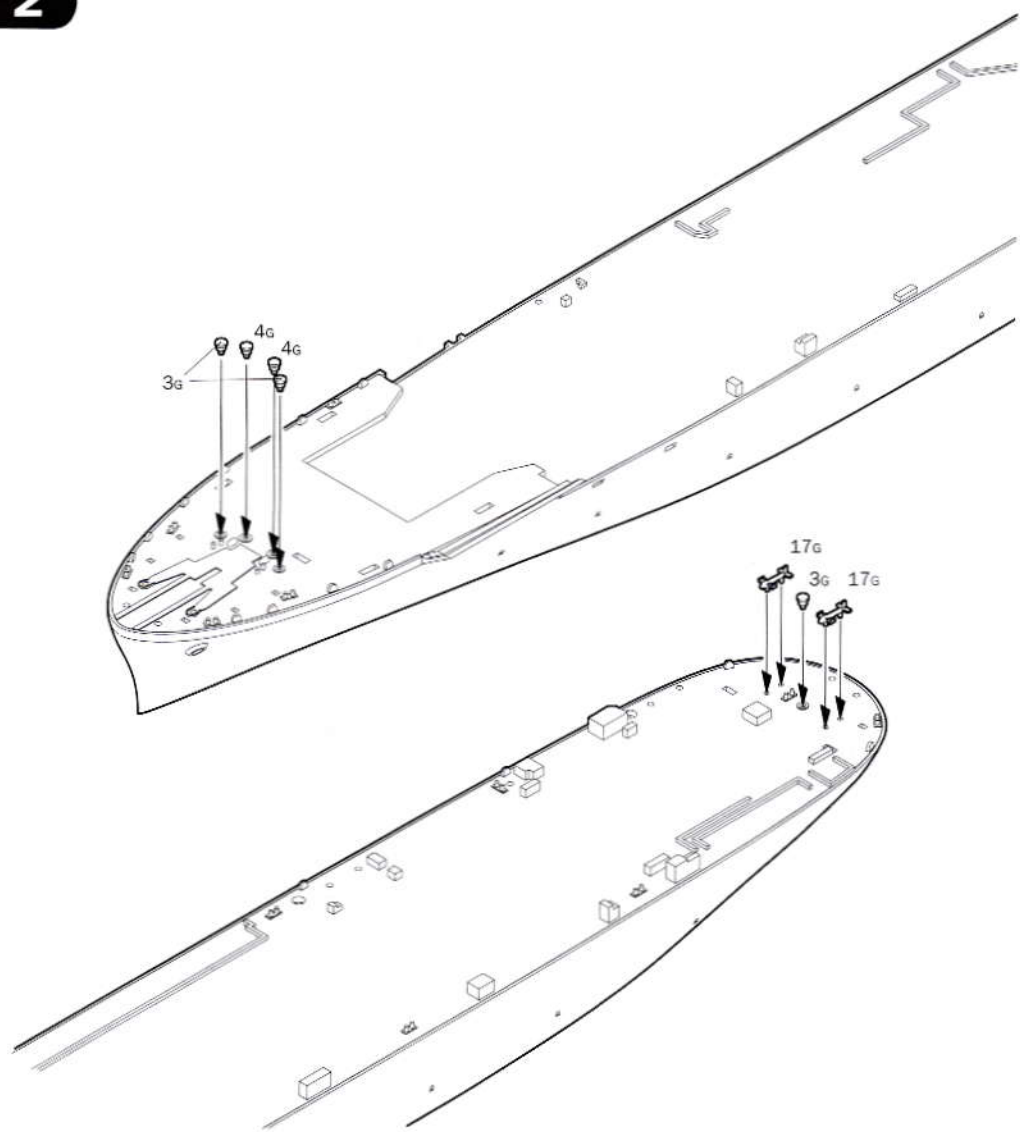
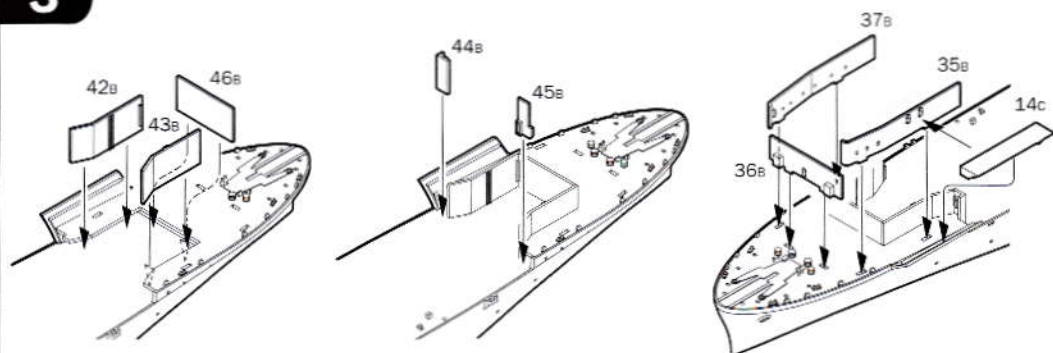
2**3**

4

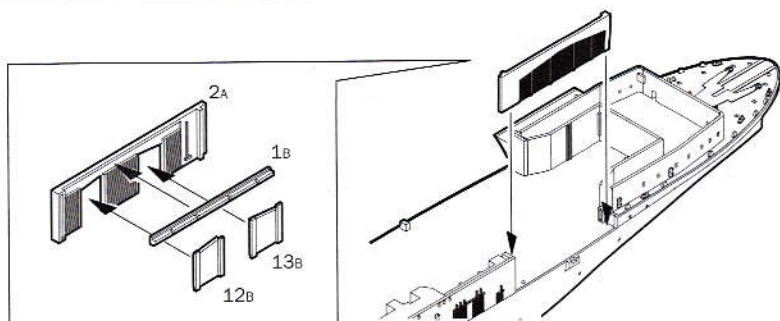

5

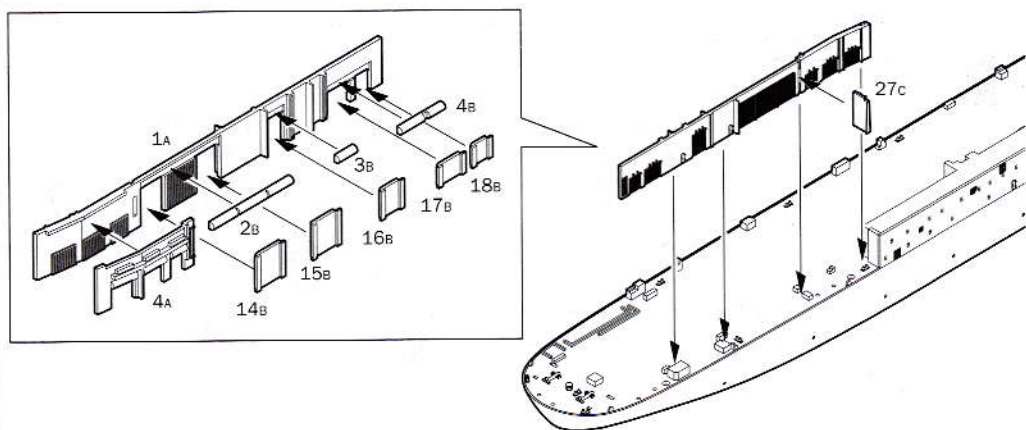
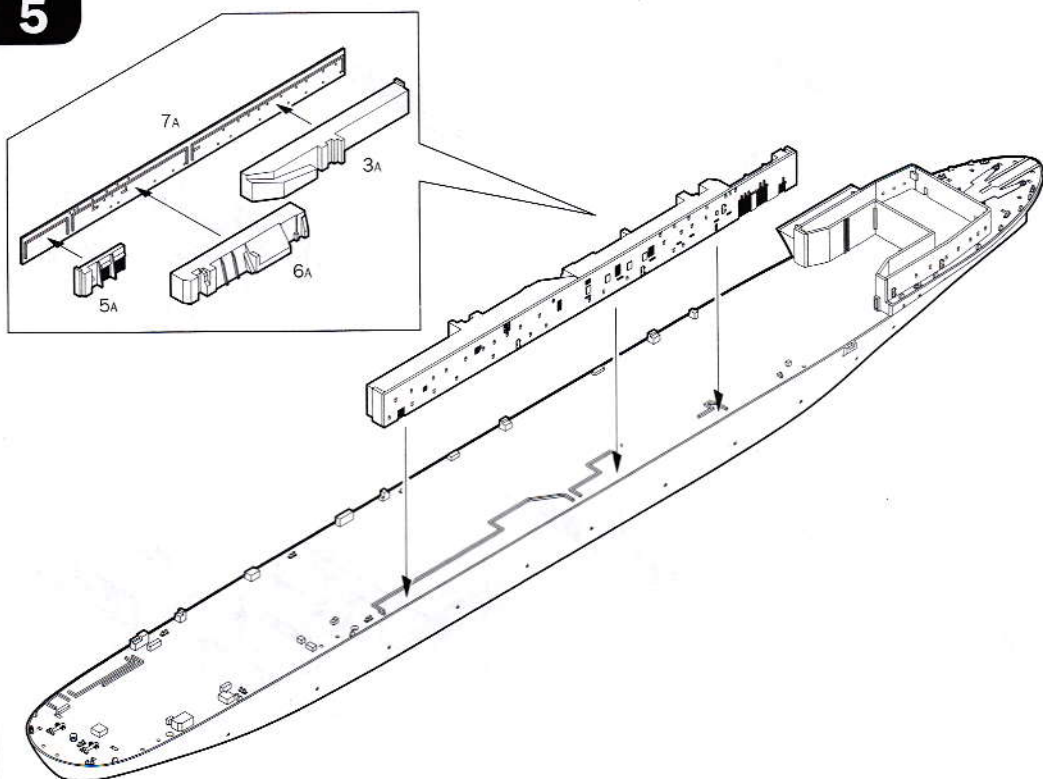

6

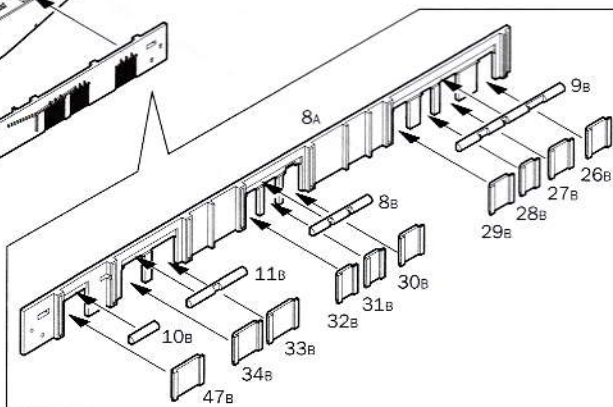
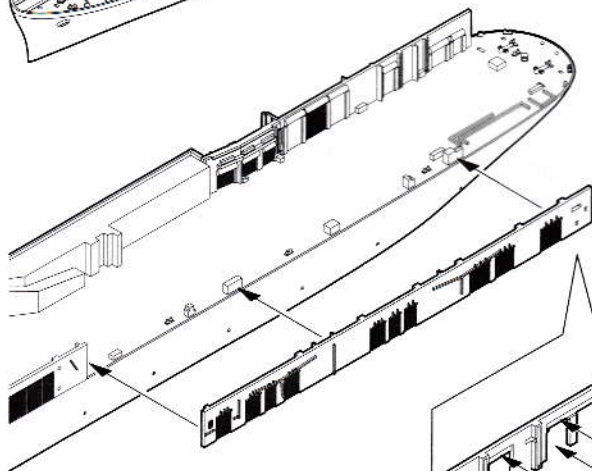
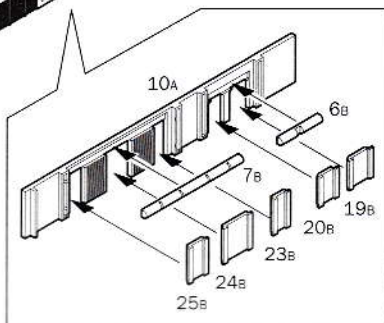
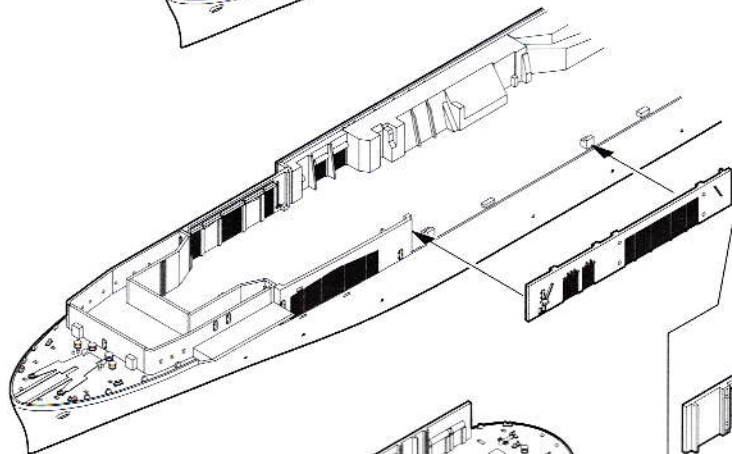
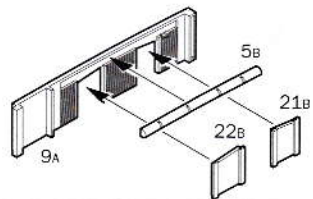
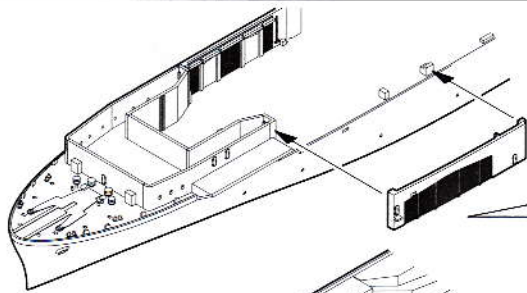

7

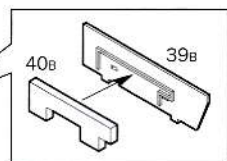
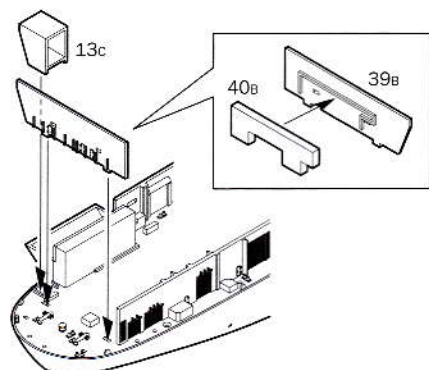
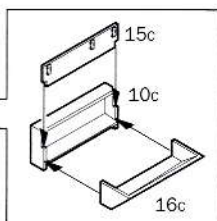
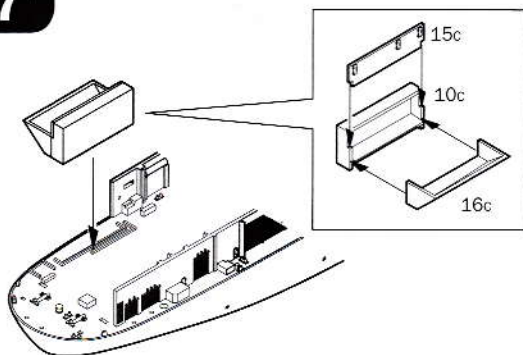

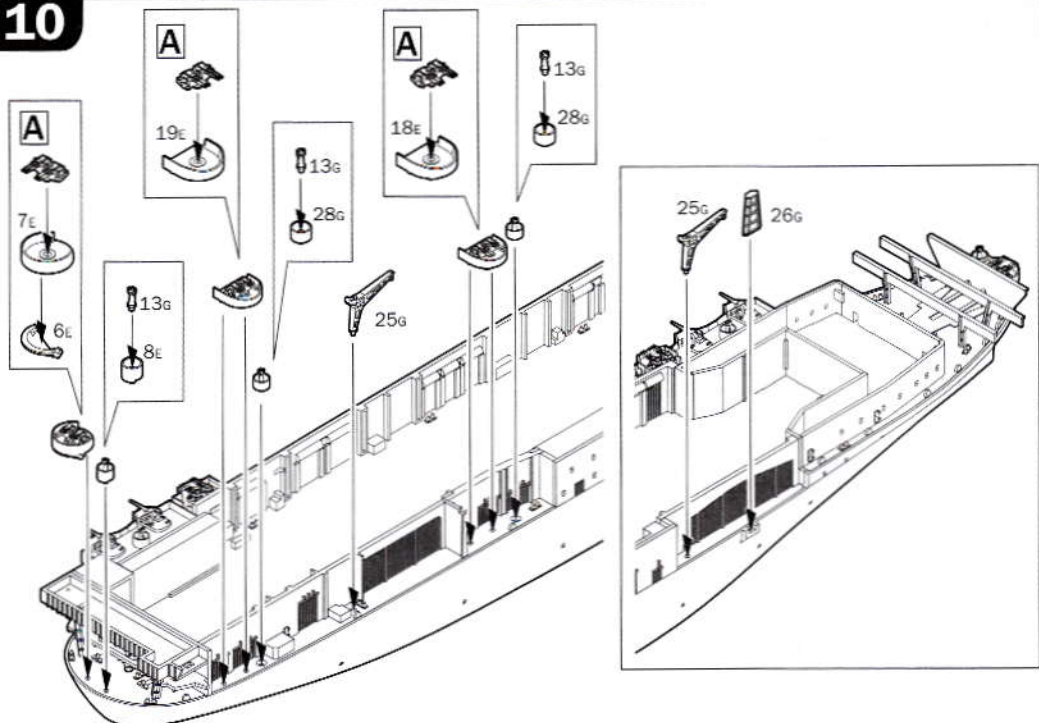
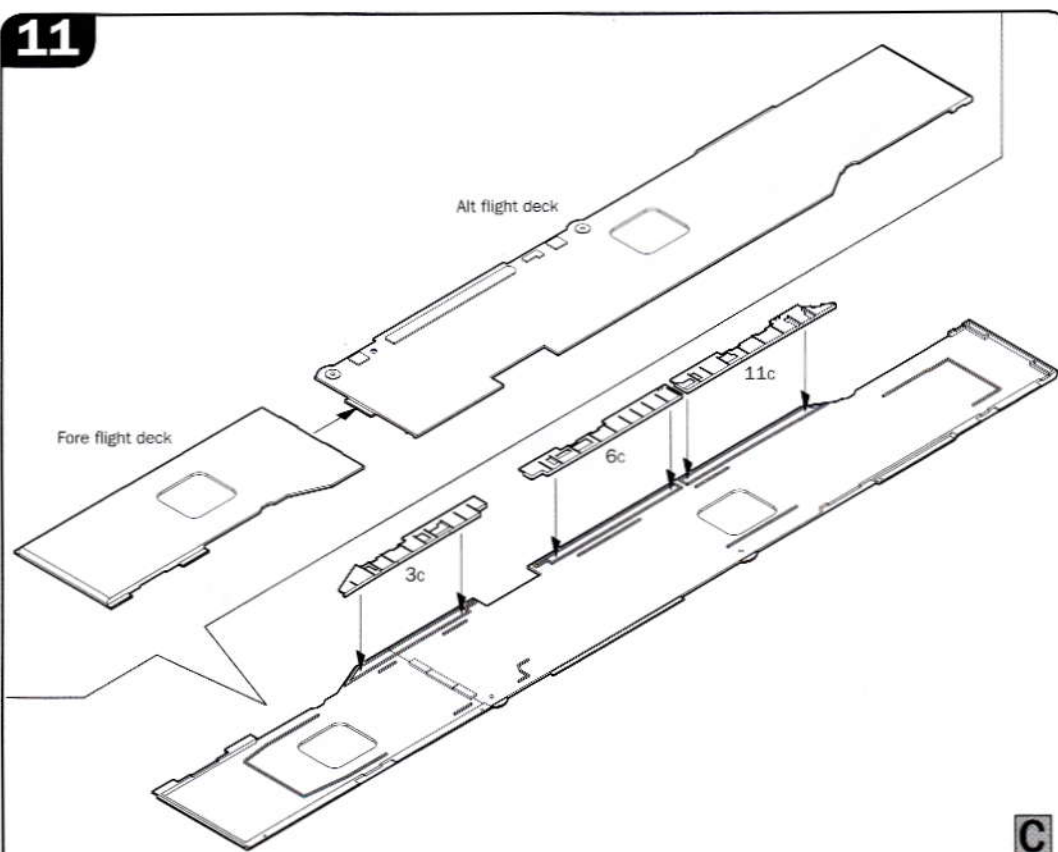
10**11****C**

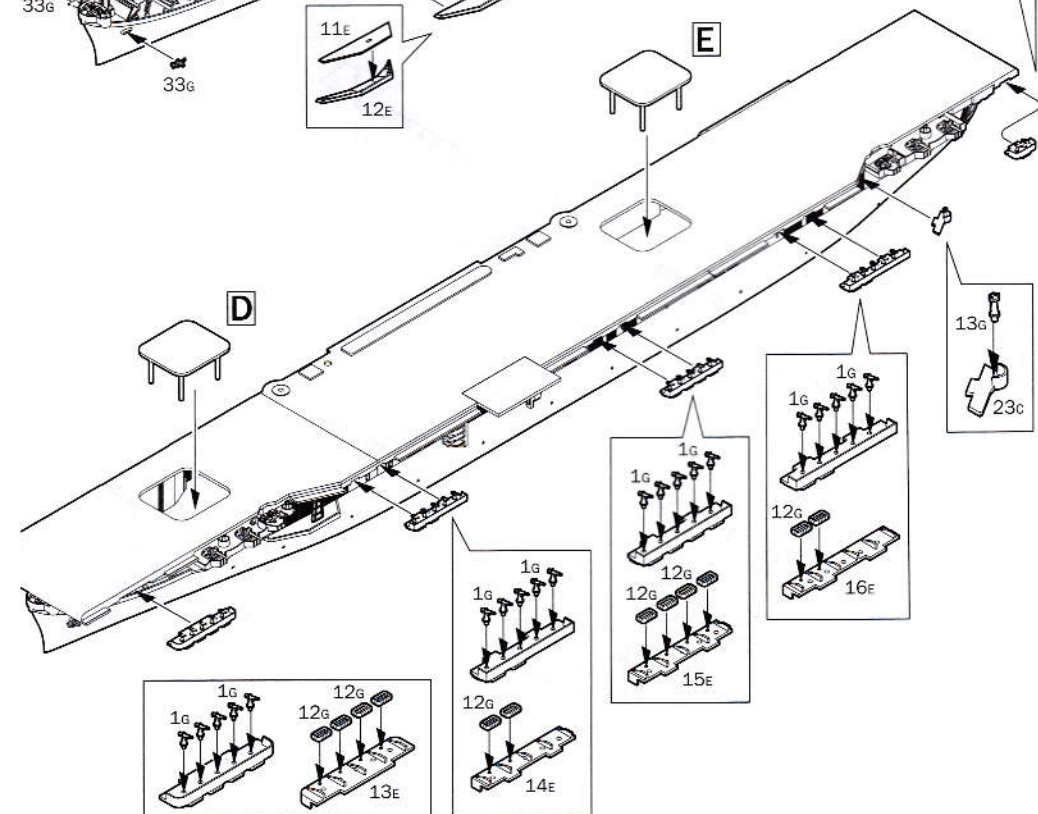
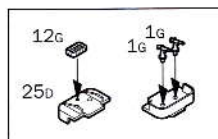
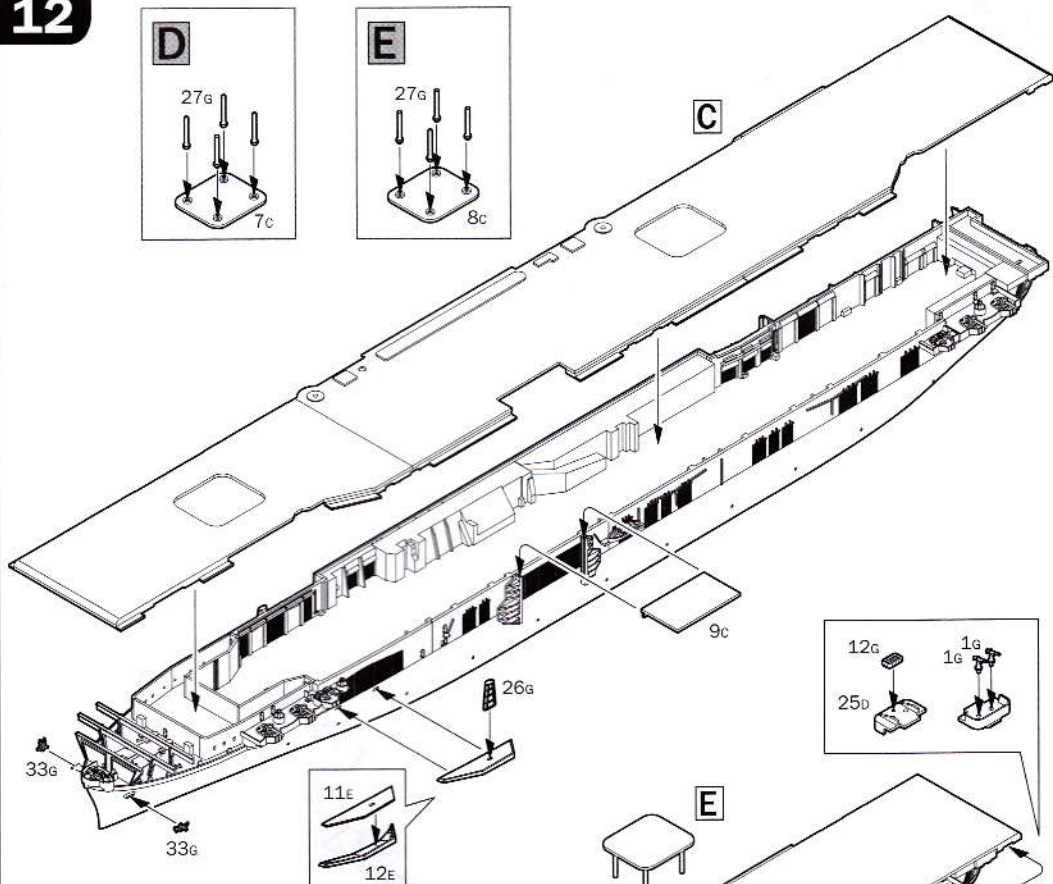
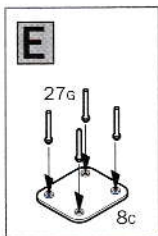
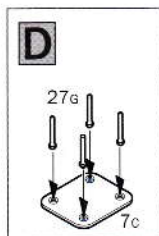

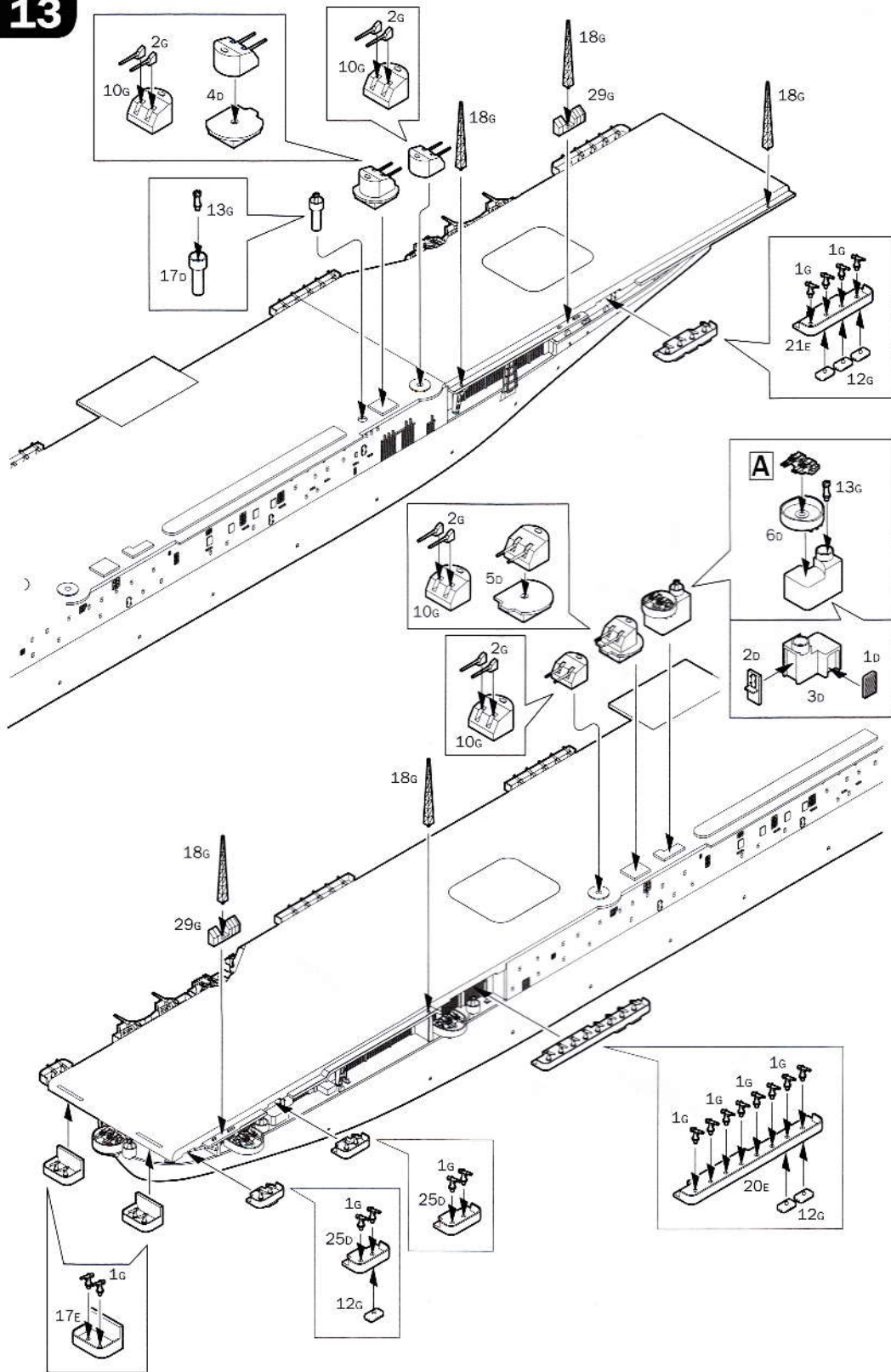

4X F4U

FLAT NON SPECULAR SEA BLUE

F.S. 35042

ITALERI ACRYLICPAINT - 4604AP

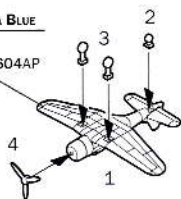

4X F6F

FLAT NON SPECULAR SEA BLUE

F.S. 35042

ITALERI ACRYLICPAINT - 4604AP

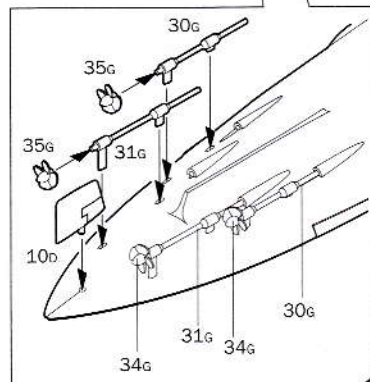
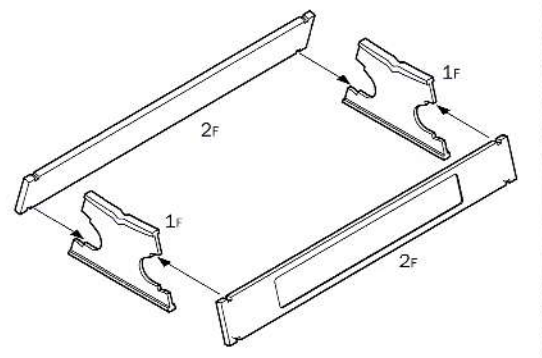
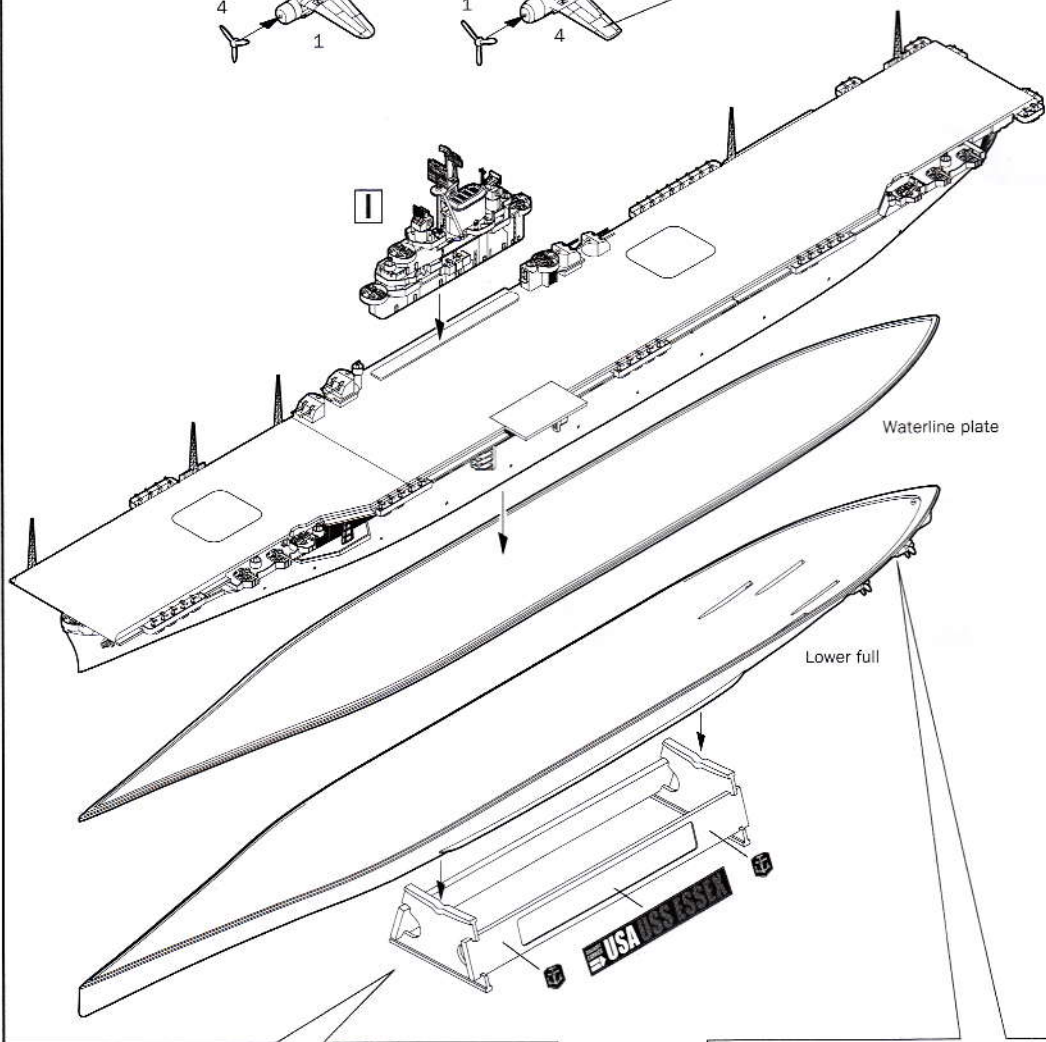
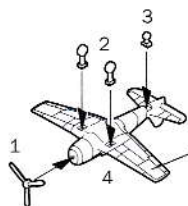

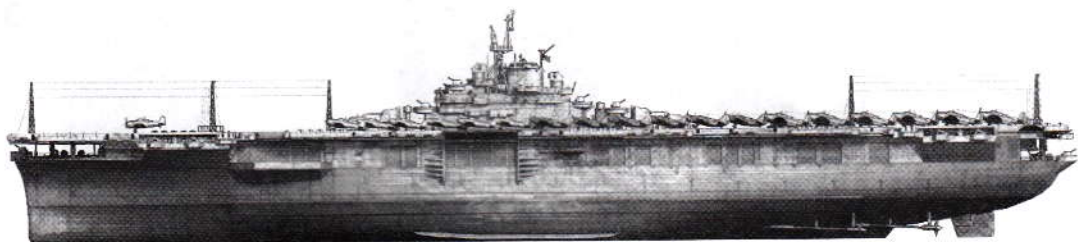
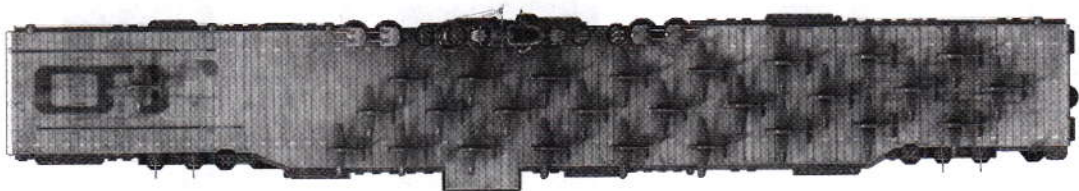

ISTRUZIONI PER APPLICARE CORRETTAMENTE LE DECALS

1) Ritagliare, con attenzione, il soggetto prescelto seguendo i contorni. 2) Immergerlo in acqua tiepida. 3) Separarlo dal supporto. 4) Posizionare l'adesivo sul modello - asciugando con l'aiuto di un panno - eliminare le eventuali bolle d'aria spingendole all'esterno.

STEPS TO FOLLOW IN ATTACHING THE DECALS PROPERLY.

1) Cut out the subject you have chosen, being very careful to clip along its outlines so as not to leave any ragged edges. 2) Soak it for a few seconds in warm water. 3) Carefully separate it from its backing. 4) Place the decal on the model. Remove all drops of water with a dry cloth. Any air bubbles which may have formed can be removed by gently squeezing them out to the edges of the decal.

MODE D'EMPLOI POUR L'APPLICATION DES ADHESIFS.

1) Découper attentivement le sujet choisi en suivant les contours. 2) Le plonger dans de l'eau tiède. 3) Le séparer de son support. 4) Placer l'adhesif sur le modèle - l'essuyer avec une lingette et éliminer les bulles d'air éventuelles en les faisant glisser vers l'extérieur.

ANLEITUNG FÜR DAS RICHTIGE ANBRINGEN DER ABZIEHBILDER.

1) Das gewählte Bild sorgfältig nach den Konturen ausschneiden. 2) In lauwarmes Wasser legen. 3) Es von der Unterlage ablösen. 4) Den Aufkleber auf das Modell legen - mit einem Tuch trocknen - eventuell vorhandene Luftblasen durch Drücken nach außen beseitigen.

INSTRUCTIVO PARA APLICAR CORRECTAMENTE LOS ADHESIVOS.

1) Recortar con cuidado el sujeto escogido siguiendo la silueta. 2) Sumirlo en agua tibia. 3) Quitarlo de su soporte. 4) Situar el adhesivo en su lugar. Secarlo con un pedazo de tela. Desinflar las eventuales burbujas de aire empujandolas hacia la orilla.

INSTRUKTIES TOT HET KORREKT AANBRENGEN VAN DE TRANSFERS.

1) Het uitgekozen voorwerp voorzichtig langs de contouren uitknippen. 2) In lauw water dompelen. 3) Van de plakstrook afhalen. 4) De transfer op het model aanbrengen en met een lapje afdrogen; eventuele luchtblaasjes verwijderen door deze vanuit het midden naar buiten weg te strijken.

INSTRUKTIONER FÖR KORREKT PSÄTTNING AV ADHESIVERNA.

1) Klipp försiktigt ur det utvalda föremålet genom att följa konturerna. 2) Doppa ner det i ljummet vatten. 3) Skilj det från underlaget. 4) Sätt adhesivet på modellen. Torka det med hjälp av en trasa. Avlägsna eventuella luftbubblor genom att pressa dem utåt.

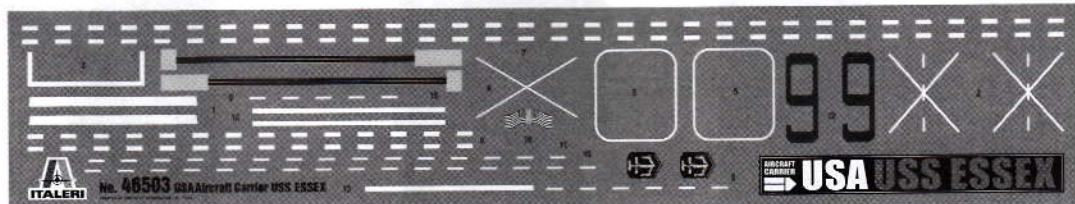
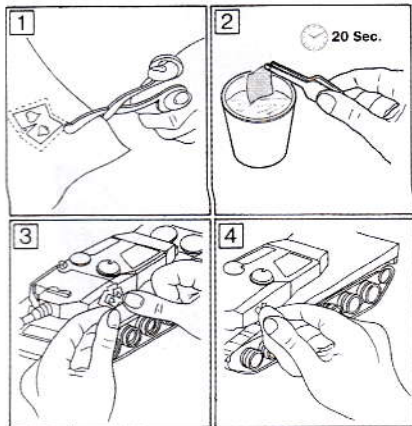

(numeri e referenze all'assortimento Italeri Acrylic Paint
 the indicated colour number refer to the Italeri Acrylic Paint
 les références indiquées concernent les peintures Italeri Acrylic Paint
 Die angegebenen Referenznummern beziehen sich auf die Italeri Acrylic Paint
 les numéros se réfèrent à los colores surtidos Italeri Acrylic Paint
 De nummers verwijzen naar het assortiment Italeri Acrylic Paint

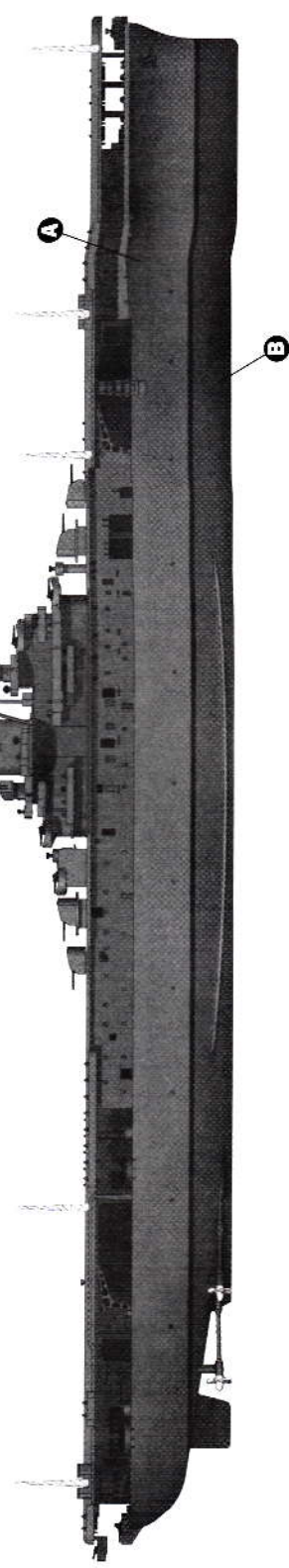
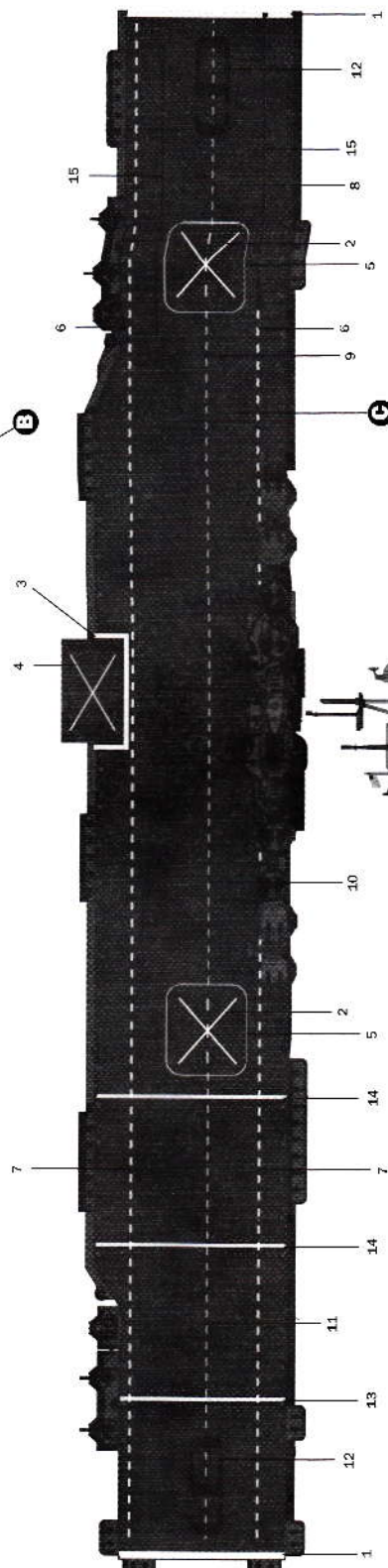
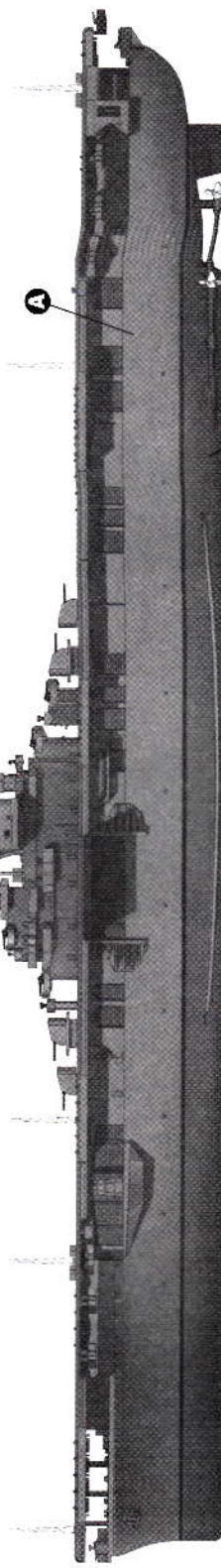

C

FLAT GUNSHIP GRAY
 F.S. 36118
 ITALERI ACRYLIC PAINT - 4752AP

B

FLAT RUST
 F.S. 30109
 ITALERI ACRYLIC PAINT - 4675AP

A

FLAT MEDIUM SEA GRAY
 F.S. 36270
 ITALERI ACRYLIC PAINT - 4313AP



KIT No 46503 Scale 1:300 - USA Aircraft Carrier USS ESSEX

NAME NOME NAME NOM NOMBRE NAAM	ADDRESS INDRIZZO ADDRESS ADRESSE DIRECCION ADRES
---	---

TOWN CITTA STADT VILLE CUCAO GEMEENTE	POSTAL CODE C.A.P. POSTLEITZAHN CODE POSTALE CÓDIGO POSTAL POSTCODE	COUNTRY NAZIONE LAND PAYS PAIS LAND	DATE OF BIRTH DATA DI NASCITA GEBURTSDATUM DATE DE NAISSANCE NACIDO: A EL GEBURTEDATUM
--	--	--	---

E-MAIL

DEFECTIVE PARTS
PARTI DIFETTOSI
DEFEKTE TEILE
PIECES DEFECTUEUSES
PIEZAS DEFECTUOSAS
DEFECTE ONKROUDELLEN

PLACE OF PURCHASE
ACQUISTATO PRESSO
ORT DI A. KAUFES
LIEU D'ACHAT
LUGAR DE COMPRA
PLAATS VAN AANKOOP

Retail Store
Negozio
Einkaufshandel
Détailiant
Detailista
Detailhandel

Hyper Market
Grande Magazzino
Ander
Grande Surface
Gran Almacén
Hypermarket

ITALERI S.p.A.
Via Pradazzo, 6/B
40012 - Calderara di Reno (BO) ITALY
fax: 0039 51 726 459
e-mail: Italeri@Italeri.com
www.italeri.com

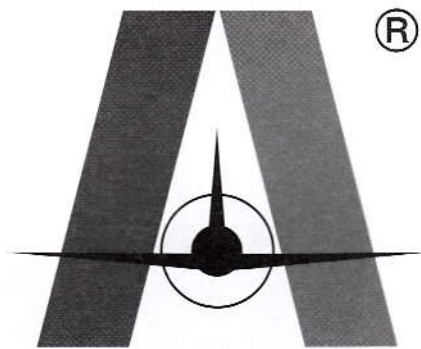

ITALERI