



Via Pradazzo, 6/b
40012 Calderara di Reno
Bologna - Italy
www.italeri.com

Conservare il presente
indirizzo per futuro
riferimento

Retain this address
for future
reference

made in Italy

1:35 scale

No 6549

Steyr RSO/01

with german soldiers and accessories

EN

In order to cope with the poor road conditions on the Eastern front, the Germans built tracked tractors to tow all types of vehicles and also serve to carry various loads from ammunition to food supplies. The official description of this vehicle was "Raupenschlepper-Ost" (tracked tractor-East). The RSO/1 was built by the Steyr-works in then annexed Austria. It had a commercial-type pressed steel cab, but a wooden cargo body. It proved ideal for the mud and slush conditions of the Russian front. The vehicles were part of the desperate German efforts to avoid defeat by the overwhelming Soviet armies.

DE

Um den schlechten Straßenverhältnissen an der Ostfront gerecht zu werden, bauten die Deutschen Raupenschlepper, um alle Arten von Fahrzeugen zu ziehen und auch dazu zu dienen, verschiedene Frachten von Munition bis Lebensmittel zu befördern.

Die offizielle Bezeichnung dieses Fahrzeuges war „Raupenschlepper-Ost“. Der RSO/1 wurde von den Steyrwerken in dem damals annektierten Österreich gebaut. Er hatte eine Fahrerkabine eines handelsüblichen Typs aus Eisenplatten. Der Ladeaufbau war jedoch aus Holz. Das Fahrzeug war ideal für die aufgeweichten, schlammigen Bedingungen an der russischen Front. Die Fahrzeuge waren Teil der verzweifelten deutschen Anstrengungen, die Niederlage durch die übermächtigen Sowjetarmeen zu vermeiden.

ES

Para adaptarse a las pobres condiciones de las carreteras del frente Oriental, los alemanes construyeron unidades tractoras dotadas de cadenas, para remolcar todo tipo de vehículos y también para transportar cargas diversas, desde municiones hasta alimentos. La descripción oficial de este vehículo era "Raupenschlepper-Ost" (tractor con cadenas-Este).

El RSO/1 fue construido por la factoría Steyr, en la entonces anexionada Austria. Tenía una cabina comercial de acero prensado, siendo la estructura de carga de madera. Demostró ser ideal para desenvolverse en el lodo y la nieve fangosa del frente ruso. Los vehículos fueron parte de los esfuerzos desesperados de los alemanes para evitar la derrota a manos de los arrolladores ejércitos soviéticos.

IT

Per far fronte alle disagiati condizioni delle strade sul fronte orientale, i tedeschi costruirono trattori a cingoli per rimorchiare tutti i tipi di veicoli e per trasportare diversi carichi, fra cui munizioni e viveri. La denominazione ufficiale di questo tipo di macchina era "Raupenschlepper-Ost" (Trattore a cingoli-Est).

Il RSO/1 fu costruito dalla STEYR nell'Austria allora annessa alla Germania. Aveva una cabina di guida di tipo commerciale fatta di lamiera di ferro. Il cassone di carico però era di legno. Questo trattore si dimostrò un veicolo ideale per il fango e la melma sul fronte russo. Questi veicoli fecero parte degli sforzi disperati dei tedeschi per evitare la sconfitta da parte delle preponderanti forze armate sovietiche sul fronte russo.

FR

Pour venir à bout des lamentables conditions de circulation sur les routes du front de l'Est, les Allemands construisirent des tracteurs tout terrain pour remorquer n'importe quel type de véhicule et pour servir également à transporter différents approvisionnements, de la nourriture aux munitions. La désignation officielle de ce véhicule était «Raupenschlepper-Ost» (tracteur tout terrain-Est).

Le RSO/1 fut construit par les usines Steyr, dans l'Autriche annexée. Il possédait une cabine de type commerciale en acier embouti, mais une carrosserie de camion en bois. Il se idéal pour les conditions enneigées et bourbeuses du front russe. Ces véhicules font partie des efforts désespérés des Allemands pour éviter la défaite face à la supériorité des armées soviétiques.

NL

Om het hoofd te kunnen bieden aan de slechte conditie van de wegen aan het Oostfront, bouwden de Duitsers rupsvoertuigen voor het trekken van allerlei voertuigen en het vervoer van munitie en voedsel. De officiële benaming was "Raupenschlepper-Ost".

De RSO/1 werd gebouwd bij de Steyr-fabrieken in het toenmalig geannexeerde Oostenrijk. De tractor had een van staalplaat geperste cabine, maar een laadbak van hout. Het voertuig was ideaal voor de modderige wegen en de zachte bodem aan het Russische front. De bouw van deze voertuigen vormde een deel van de wanhopige pogingen van de Duitsers om een nederlaag in Rusland te voorkomen.



- EN **WARNING:** For adult collectors age 14 and over.
- IT **ATTENZIONE:** Per collezionisti adulti di età superiore a 14 anni.
- DE **ACHTUNG:** Modellbausatz für Modellbauer ab 14 Jahre.
- FR **ATTENTION:** Pour modélistes de 14 ans et plus.
- ES **WAARSCHWING:** Geschikt voor 14 jaar en ouder.
- NL **ATENCION:** Para modelistas mayores de 14 años.

EN ATTENTION - Useful advice!

Study the instructions carefully prior to assembly. Remove parts from frame with a sharp knife or a pair of scissor and trim away excess plastic. Do not pull of parts. Assemble the parts in numerical sequence. Use plastic cement ONLY and use cement sparingly to avoid damaging the model. Black arrows indicate parts to be glued together. White arrows indicate on which frame the parts must be assembled WITHOUT using cement. These letters (A - B - C...) indicate on which frame the parts will be found. Paint small parts before detaching them from frame. Remove paint-where parts are to be cemented. Crossed out parts must not be used.

IT ATTENZIONE - Consigli utili!

Prima di iniziare il montaggio studiare attentamente il disegno. Staccare con molta cura i pezzi dalle stampe, usando un taglia-balsa oppure un paio di forbici e togliere con una piccola lima o con carta vetro fine eventuali sbavature. Mai staccare i pezzi con le mani. Montarli seguendo l'ordine delle numerazione delle tavole. Eliminare dalla stampata il numero del pezzo appena montato facendogli sopra una croce. Le frecce nere indicano i pezzi da incollare, le frecce bianche indicano i pezzi da montare senza colla. Usare solo colla per polistirolo. Le lettere (A - B - C...) ai lati dei numeri indicano la stampata ove si trova il pezzo da montare. I pezzi sbarrati da una croce non sono da utilizzare.

DE ACHTUNG - Ein nützlicher Rat!

Vor der Montage die Zeichnung aufmerksam studieren. Die einzelnen Montageteile mit einem Messer oder einer Schere vom Spritzling sorgfälling entfernen. Eventuelle Grate werden mit einer Klinge oder feinem Schmirgelpapier beseitigt. Keinesfalls die Montageteile mit den Händen entfernen. Bei der Montage der Tafelnummerierung folgen. Pfeile zeigen die zu klebenden Teile während die weissen Pfeile die ohne Leim zu montierenden Teile anzeigen. Bitte nur Plastikklebstoff verwenden. Die Buchstaben (A - B - C...) neben den Nummern zeigt, auf welchem Spritzling der zu montierende Teil zu finden ist. Die mit einem Kreuz markierten Teile sind nicht zu verwenden.

FR ATTENTION - Conseils utiles!

Avant de commencer le montage, étudier attentivement le dessin. Détacher avec beaucoup de soin les morceaux des moules en usant un massicot ou bien un pair de ciseaux et couper avec une petite lame avec de papier de verre fin ébarbagés éventuels. Jamais détacher les morceaux avec le mains Monter les en suivant l'ordre de la numération des tables. Eliminer de la moule le numéro de la pièce qui vient d'être montée, en le bifant avec une croix. Les flèches noires indiquent les pièces à coller, les flèches blanches indiquent les pièces à monter sans colle. Employer seulement de la colle pour polystirol. Les lettres (A - B - C...) aux côtés des numéros indiquent la moule où se trouve la pièces à monter. Les pièces marquées par une croix ne sont pas à utiliser.

NL OPGELET - Belangrijke bemerkingen!

Bestudeer zorgvuldig het montageplan voor het bouwen. Breek nooit onderdelen van het kader. Maak ze los met een scherp mes of kleine nageltang. Verwijder daarna al het overvallige plastic en pas de delen alvorens te lijmen. Gebruik allen lijm voor plastic modellen. Werk zorgvuldig en spaarzaam, teveel lijm zal uw model beschadigen. Zwarte pijlen duiden de te lijmen delen aan. Witte pijlen verwijzen naar bewegende delen welke niet mogen worden gelijmd. Deze letters (A - B - C...) geven de kaders aan waarin de onderdelen zich bevinden. Schilder de kleine onderdelen voor ze van het kader te snijden. Verwijder de verf van de te lijmen oppervlakten.

ES ATENCION - Consejos útiles!

Estudiar las instrucciones cuidadosamente antes de comenzar el montaje. Separar las piezas de las bandejas con un cuchillo afilado o un par de tijeras y retirar el exceso de plástico o rebada. No arrancar las piezas. Montar las piezas en orden numérico. Utilizar SOLAMENTE pegamento para plástico y en poca cantidad para evitar que se dane el modelo. Las flechas negras indican las piezas que se deben pegar juntas. Las flechas blancas indican las piezas que deben ensamblarse SIN usar pegamento. Las letras (A - B - C...) indican en que bandeja se encuentran las piezas. Pintar las piezas pequeñas antes de separarlas de la bandeja. Retirar la pintura de los lugares por donde se deban pegar las piezas.

A

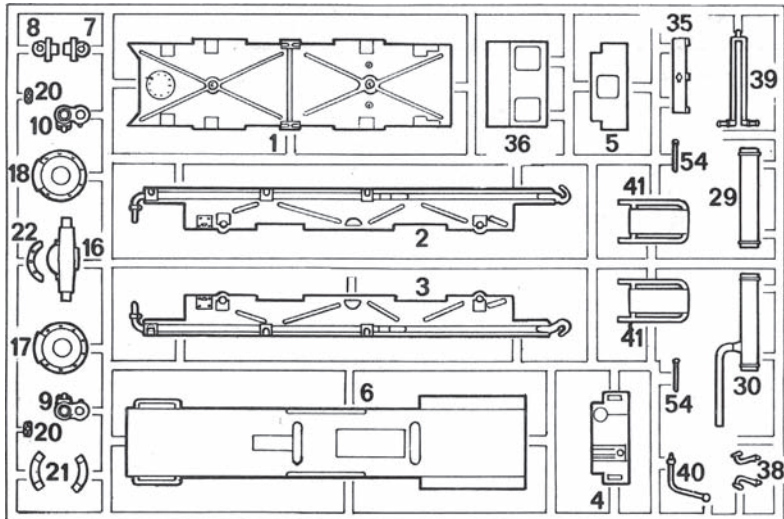

B (2x)

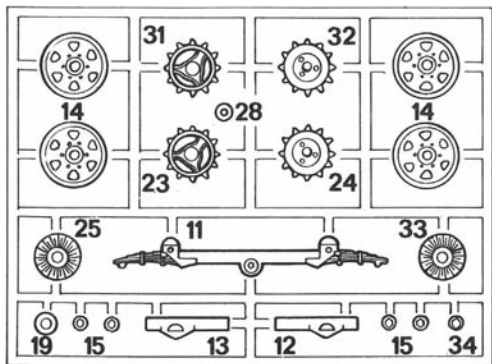
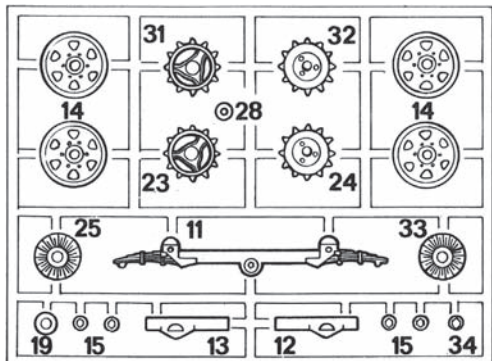

D

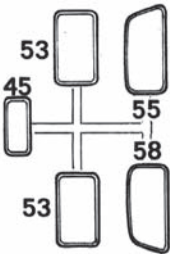

TRACKS

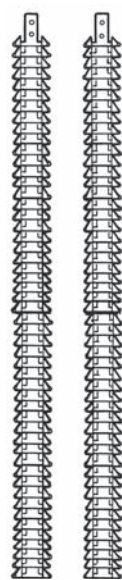

CABIN

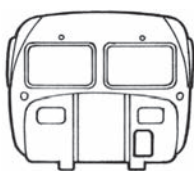

E

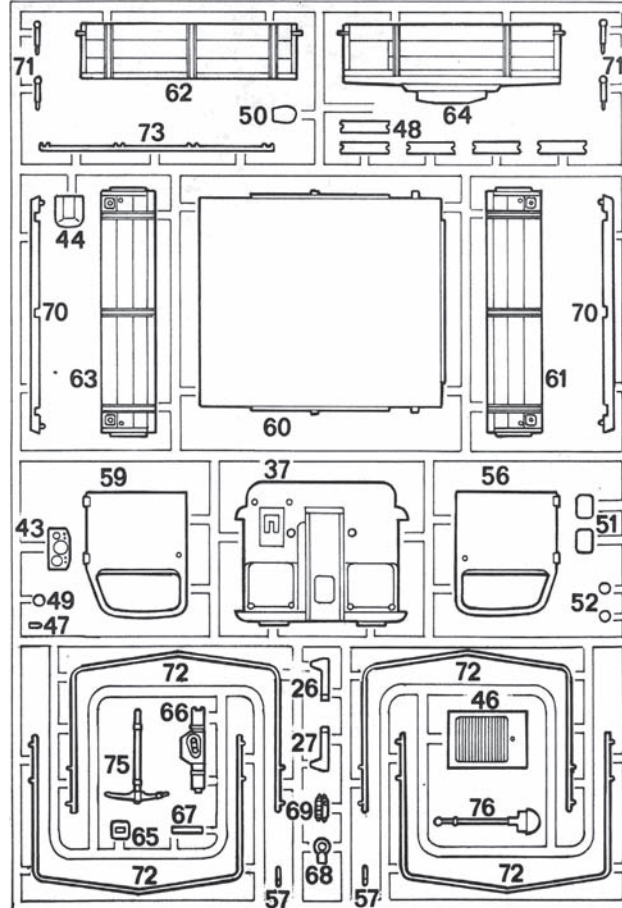

C

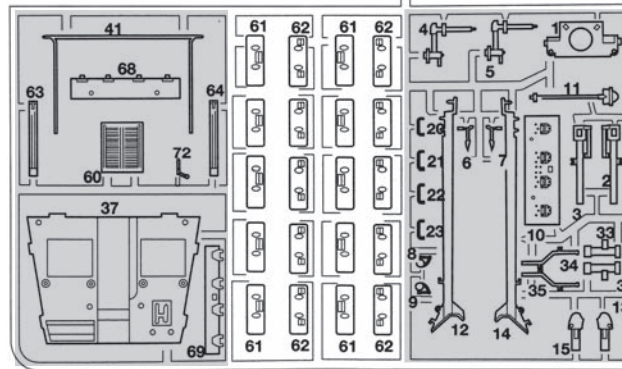

Color table

- | | |
|---|-------------------------------------|
| A FLAT RUST
4675AP | D FLAT RED
4606AP |
| B FLAT BLACK
4768AP | E METAL FLAT STEEL
4679AP |
| C Pz. SCHWARZGRAU RAL 7021
4795AP | F FLAT WOOD
4673AP |

I numeri si riferiscono all'assortimento Italeri Acrylic Paint
The indicated colour number refer to the Italeri Acrylic Paint range
Les références indiquées concernent les peintures Italeri Acrylic Paint
Die angegebenen farbnummern beziehen sich auf die Italeri Acrylic Paint
Los números se refieren a los colores surtido Italeri Acrylic Paint
De nummers verwijzen naar het assortiment kleuren Italeri Acrylic Paint

**PARTS NOT FOR USE
TELLE WERDEN NIET
VERWENDET
PARTI DA NON UTILIZZARE
PIÈCES À NE PAS UTILISER**

1

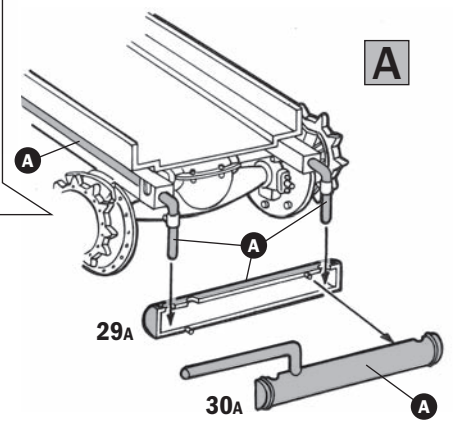
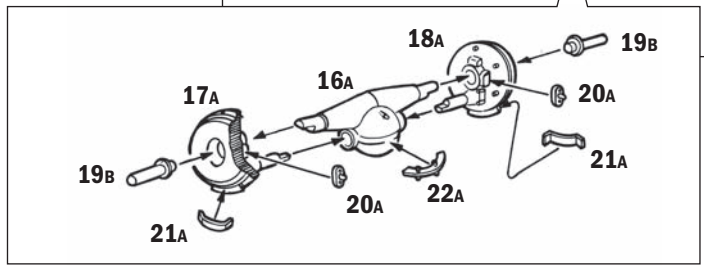
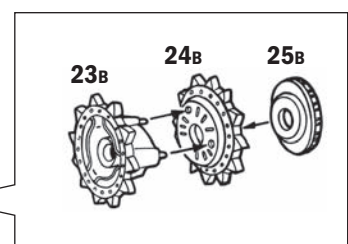
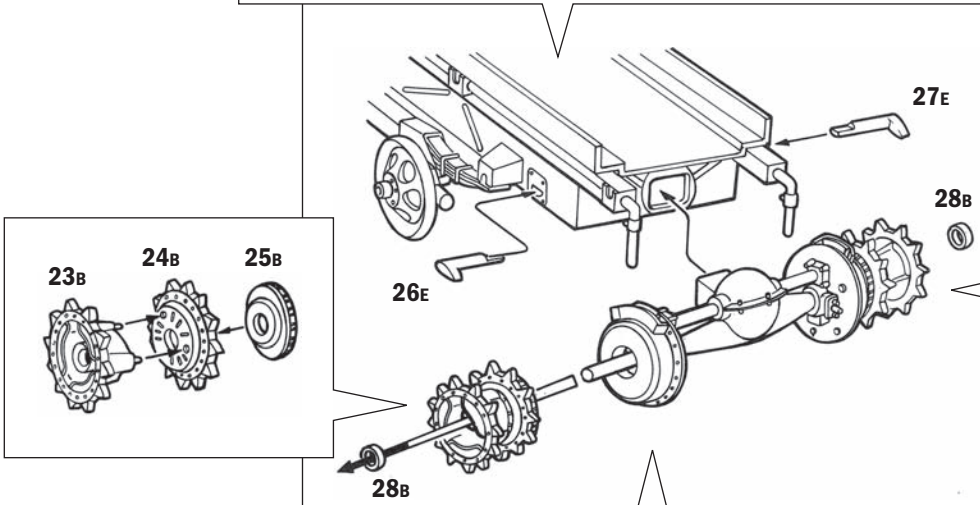
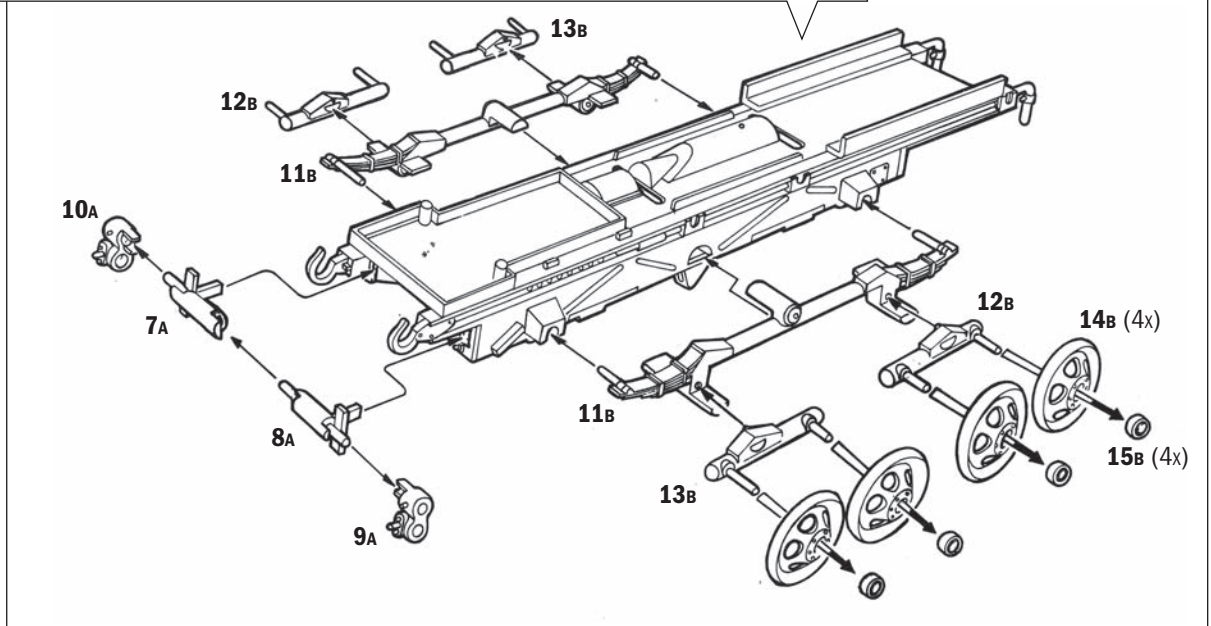
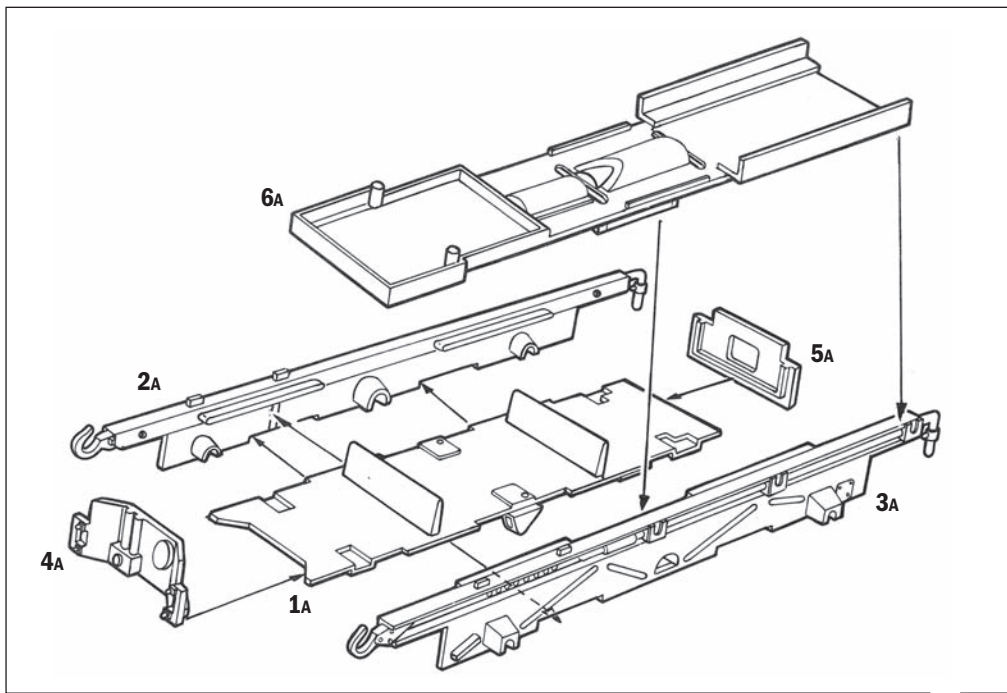

2

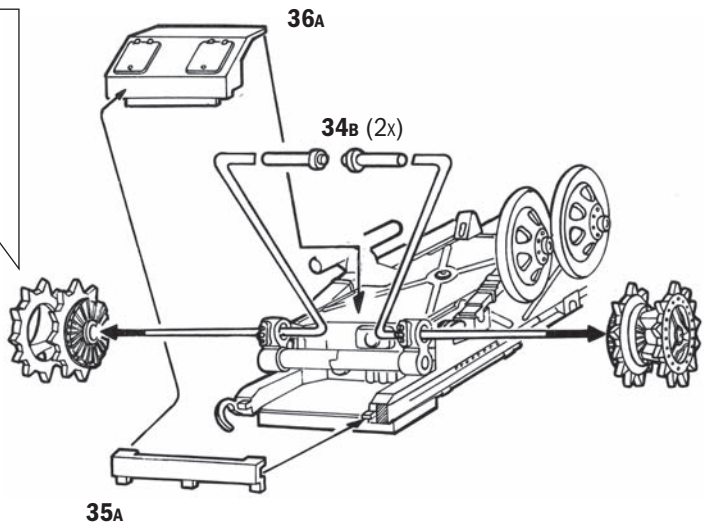
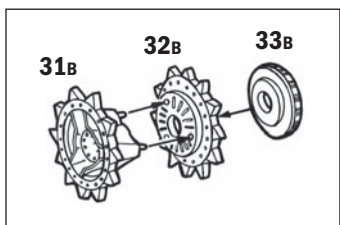

A

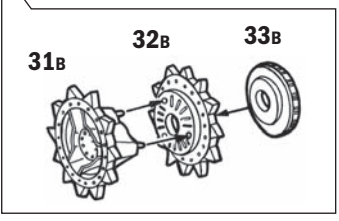

3

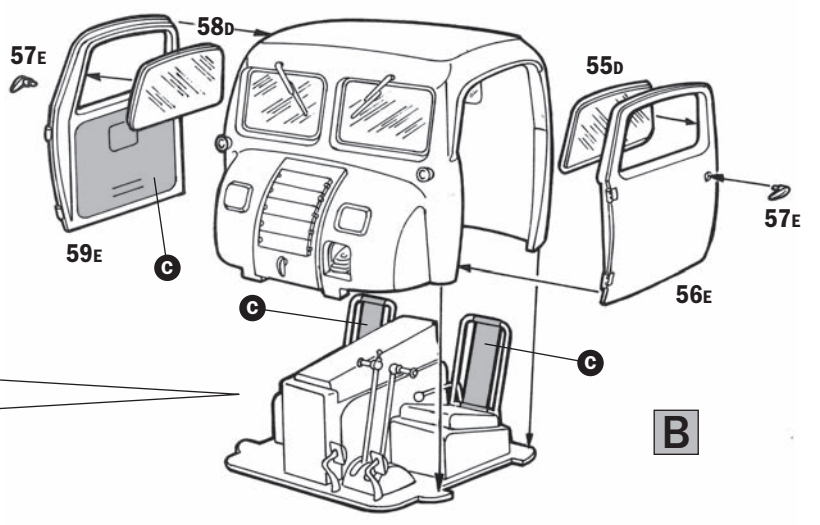
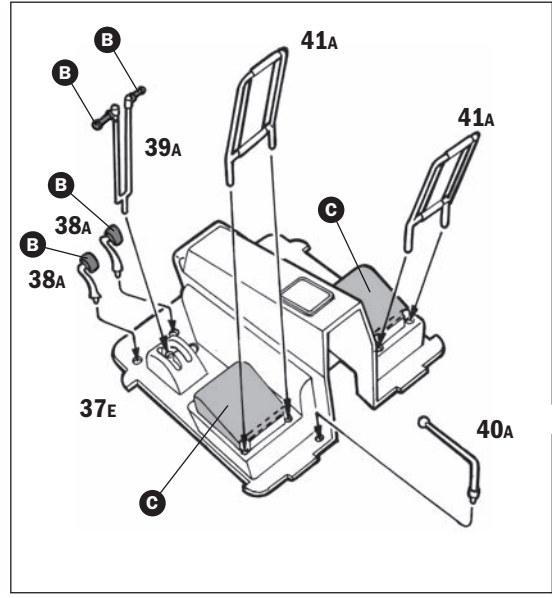
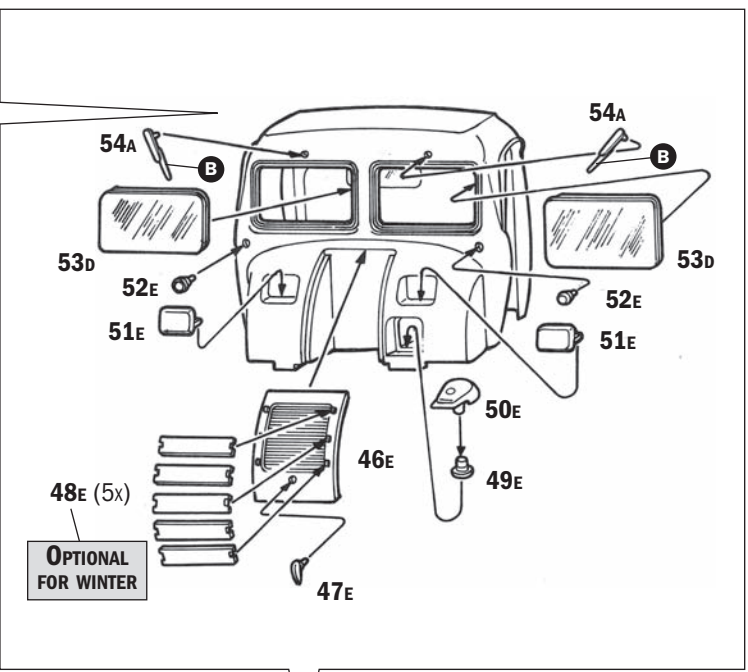
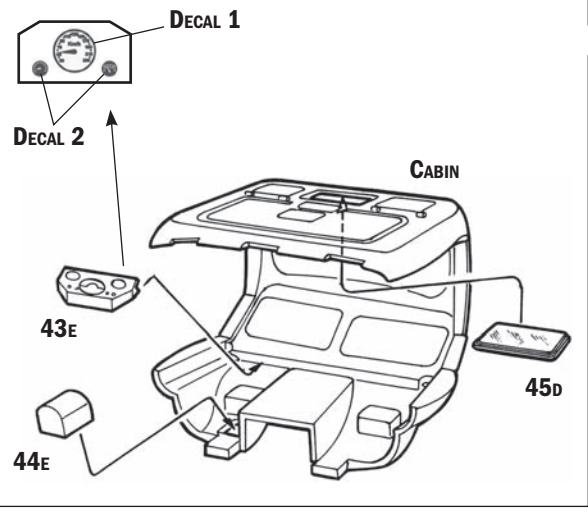

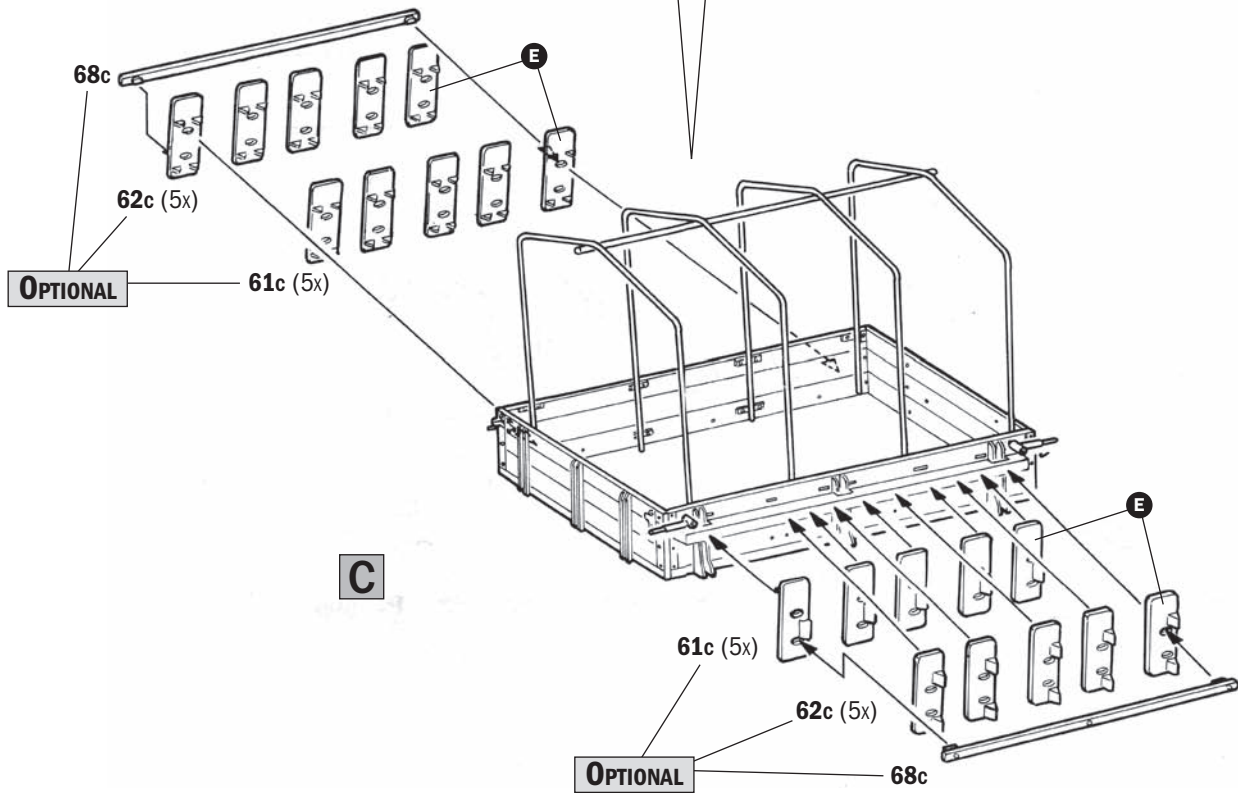
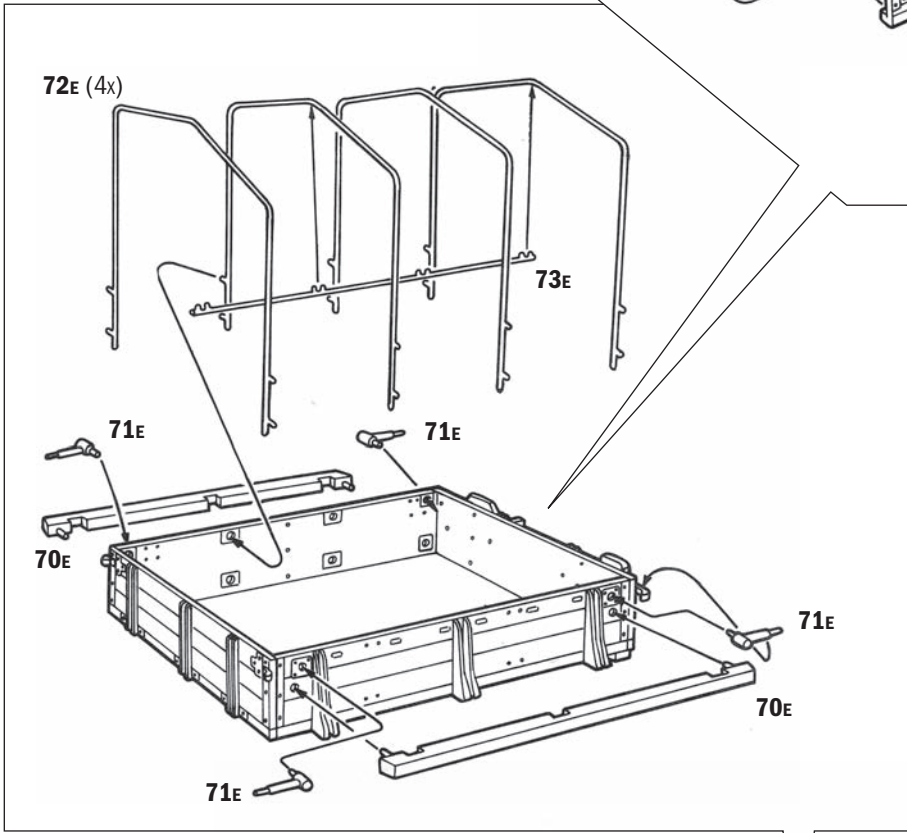
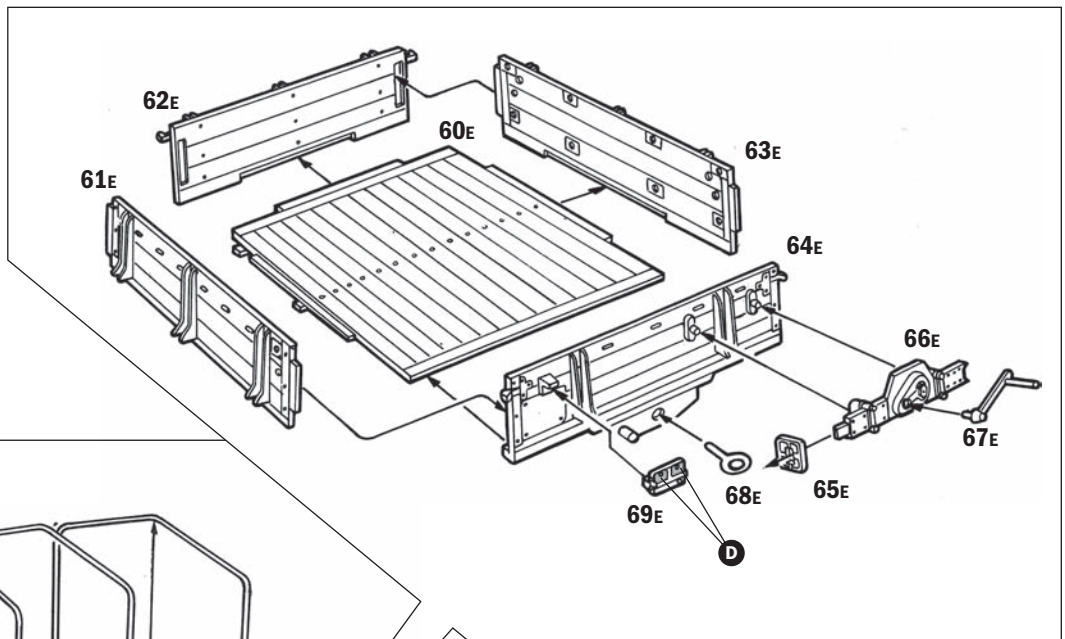

5

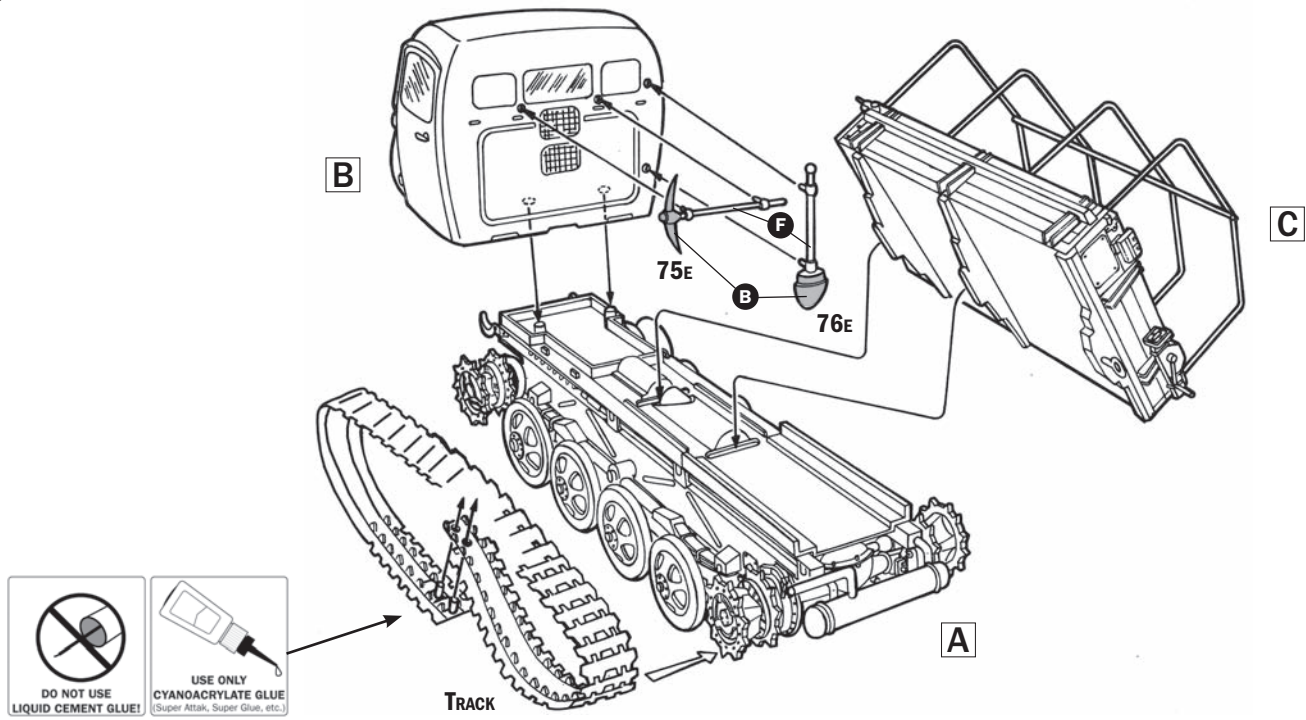

Istruzioni per l'applicazione delle decalcomanie. Ritagliare le decalcomanie occorrenti dal foglio, immergerle in un bicchiere di acqua pulita per circa 20", metterle in posizione sul modello e farle scivolare dalla carta: per una migliore aderenza comprimerle con una pezzuola pulita.

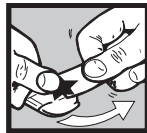

Direction for applying the decals: cut the required decals out of the sheet; dip the into a glass of clean water for about 20"; position the decals on the kit, letting them slide from the paper. For a better adesion, press them by means of a clean rag.

Påsättning av decaler: klipp ut den decal som skall användas och doppa den i ett glas vatten under en 20". Sätt decalen på plats på modellen och låt den sakta glida av pappret. För att den skall sitta ordentligt, tryck till med en torr duk.

Anweisungen für Abziehbilder-Anbringung: Die benötigten Abziehbilder vom Blatt abscheiden, in ein Glas reines Wasser für etwa 20" eintauchen, auf das Modell legen und dann vom Papierbogen abnehmen. Um eine bessere Haftung zu erzielen, die Abziehbilder mit einem reinen Tuch andrücken.

Instruction pour l'application des décalcomanies. Couper les décalcomanies choisies et les plonger environ 20" dans un peu d'eau propre. Les placer sur le modèle en les faisant glisser de leur feuille et presser avec un morceau de chiffon pour éliminer les bulles d'air.

Istruccionen Para la aplicación de las calcomanías: cortar las requeridas, sumergirlas en un recipiente de agua limpia durante 20", colocar las calcomanías sobre el modelo, haciéndolas deslizar sobre el papel. Para una mejor adherencia, presionarlas con un trapico limpio.

Transfers: knip het benodigde deel uit, dempel et ca. 20" onder water, oudt het transfer tegen het model en schuif het vanaf het papier op zijn plaats. Met een schoon doekje aandrukken.

デカール使用法 台紙から、それぞれのマークを切り取ります。ぬるま湯に20秒くらいつけて、引き上げます。マークをすべらすようにして台紙からとり、指定の位置にはってください。やわらかな布でマーク上を押して気泡を取ってください。マーク面には、かたくまで手をふれないでください。

Указания по применению декалей: Отрежьте нужную вам часть декали от общего листа, поместите ее на 1/2 минуты в чистую воду, затем, выбрав необходимое место на модели, переведите туда изображение, сдвинув его с бумажной основы. Для лучшего прилипания промажьте декаль чистой тряпочкой.

A. 278th infantry division, Italy, summer 1944.

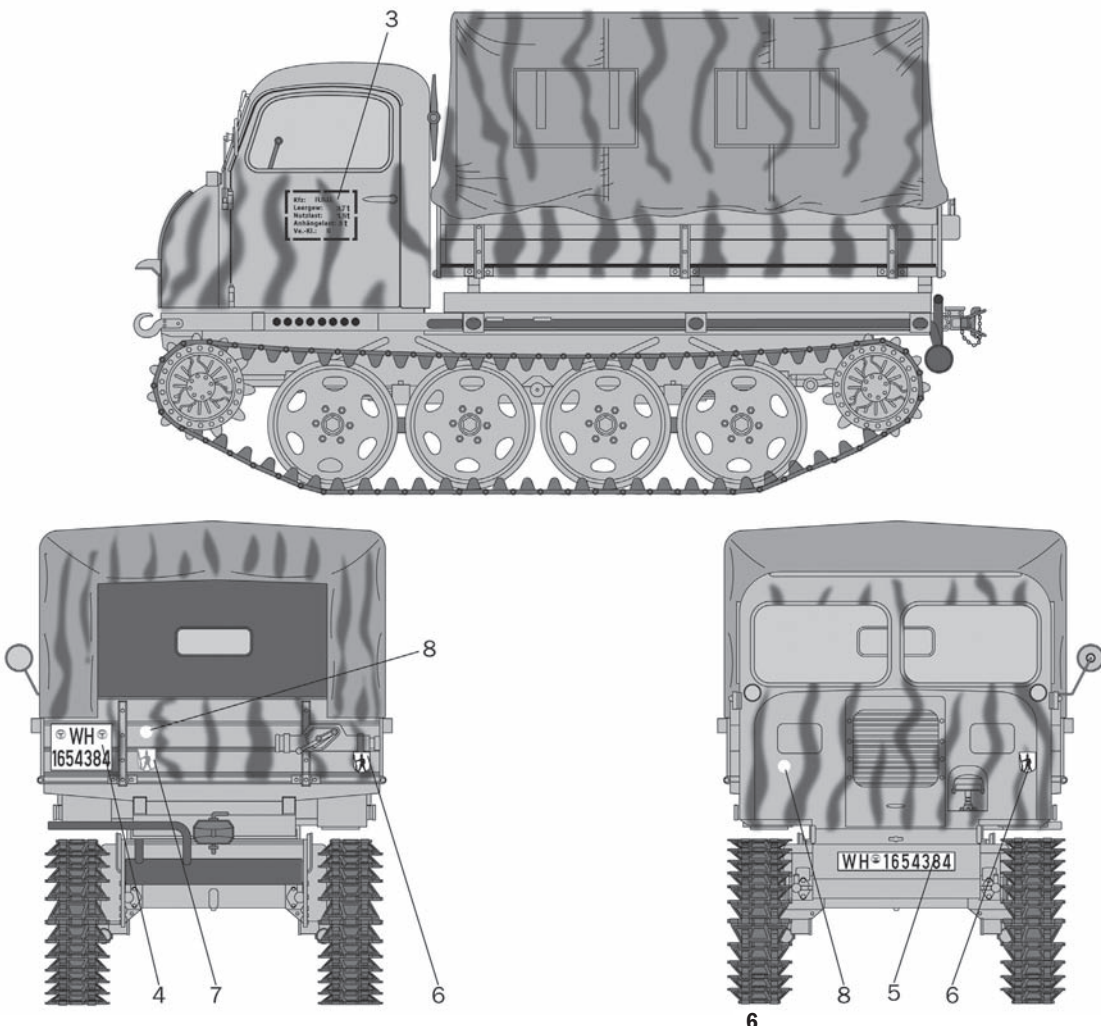

B. 12th Luftwaffe Felddivision, Kurland, 1944.

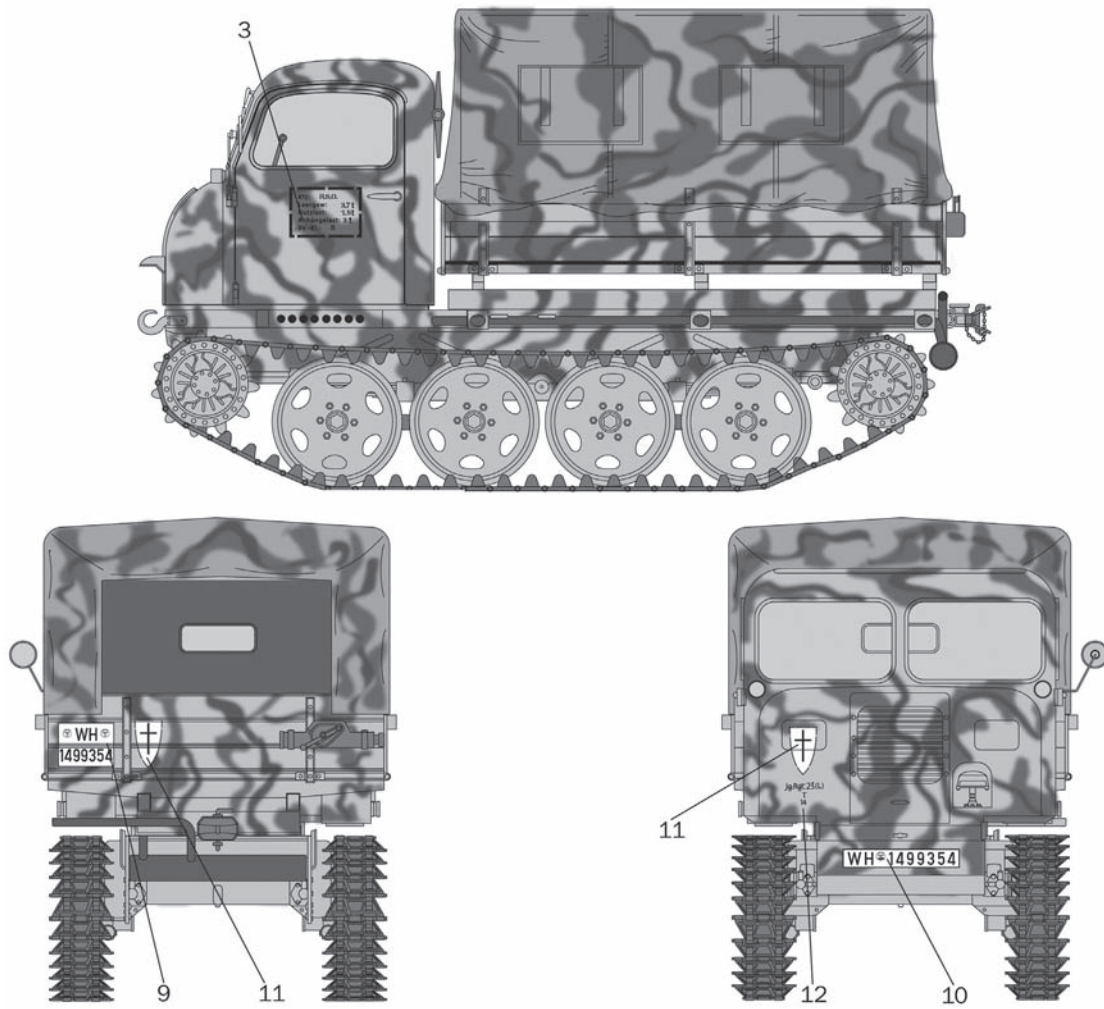

- Flat Panzer Dunkelgelb 1943 4796AP
- Flat Pz. Schokobraun RAL 8017 4797AP
- Flat Pz. Olivgrün 1943 4798AP
- Metal. Flat Steel 4679AP

C. 1th Skijäger Brigade, Pripjet marsh, Ukraine/Belarus, 1944.

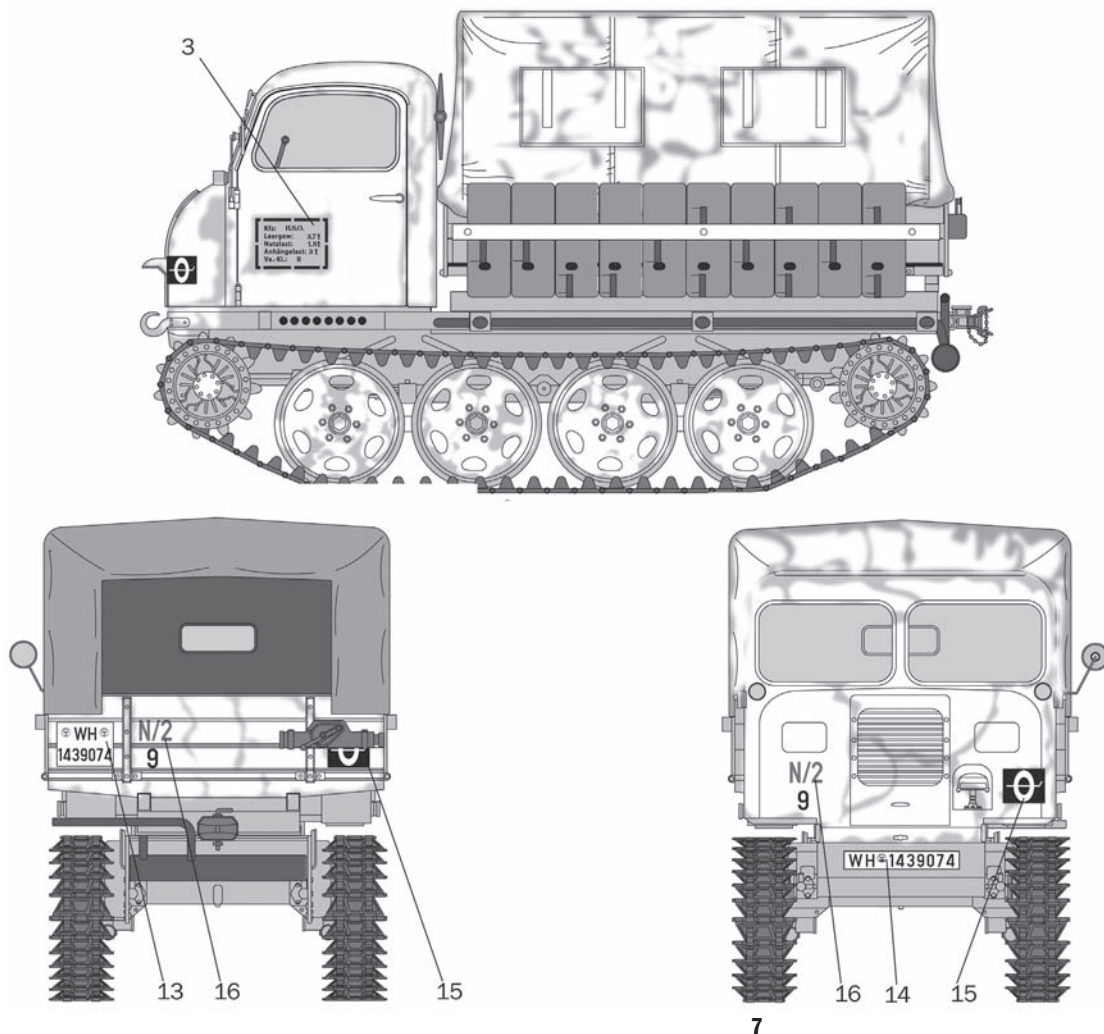

- Flat Panzer Dunkelgelb 1943 4796AP
- Flat White 4769AP
- Metal. Flat Steel 4679AP

D. Le. Art. Abt. 602 (RSO), Albania, 1943.

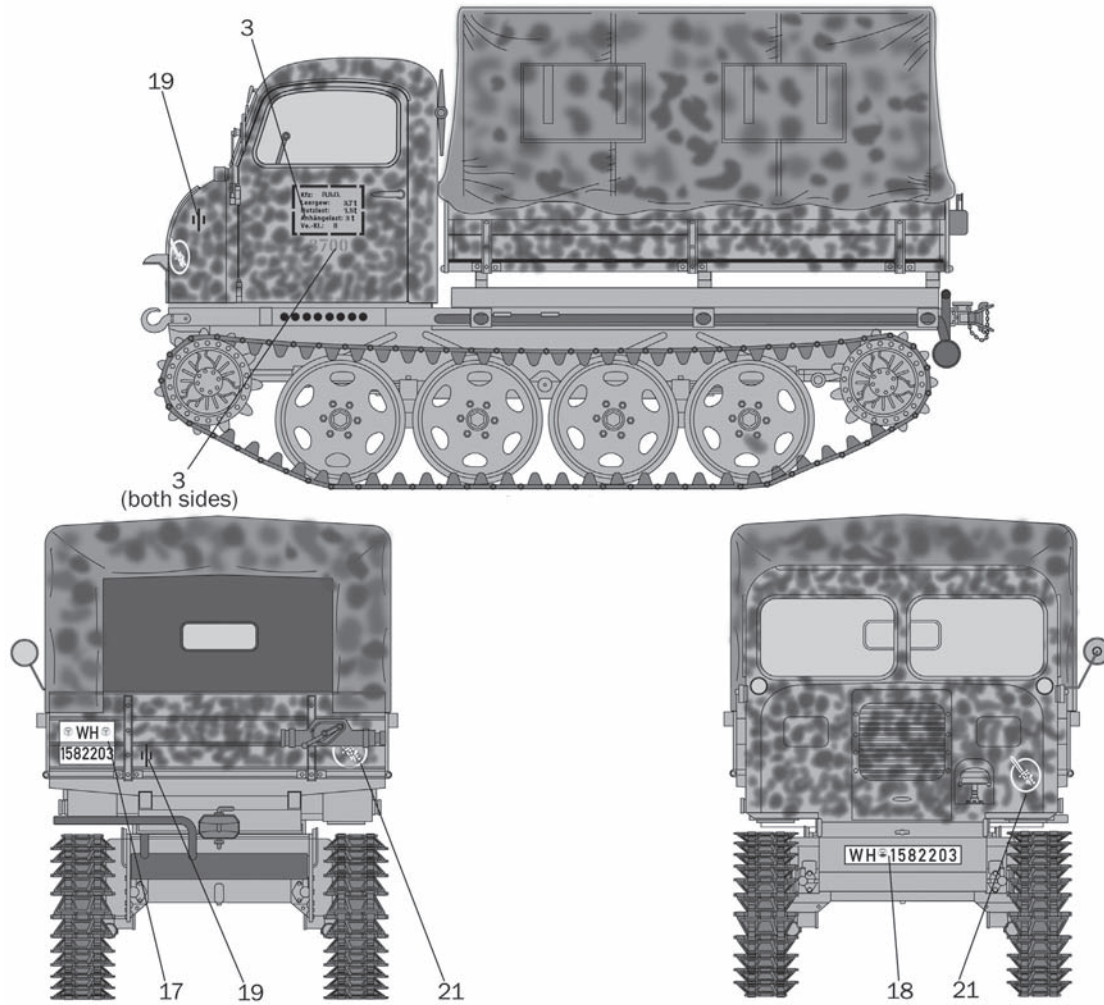

E. 19th Volksgrenadier Div., 119 Art. Rgt., Mosel area, 1944.

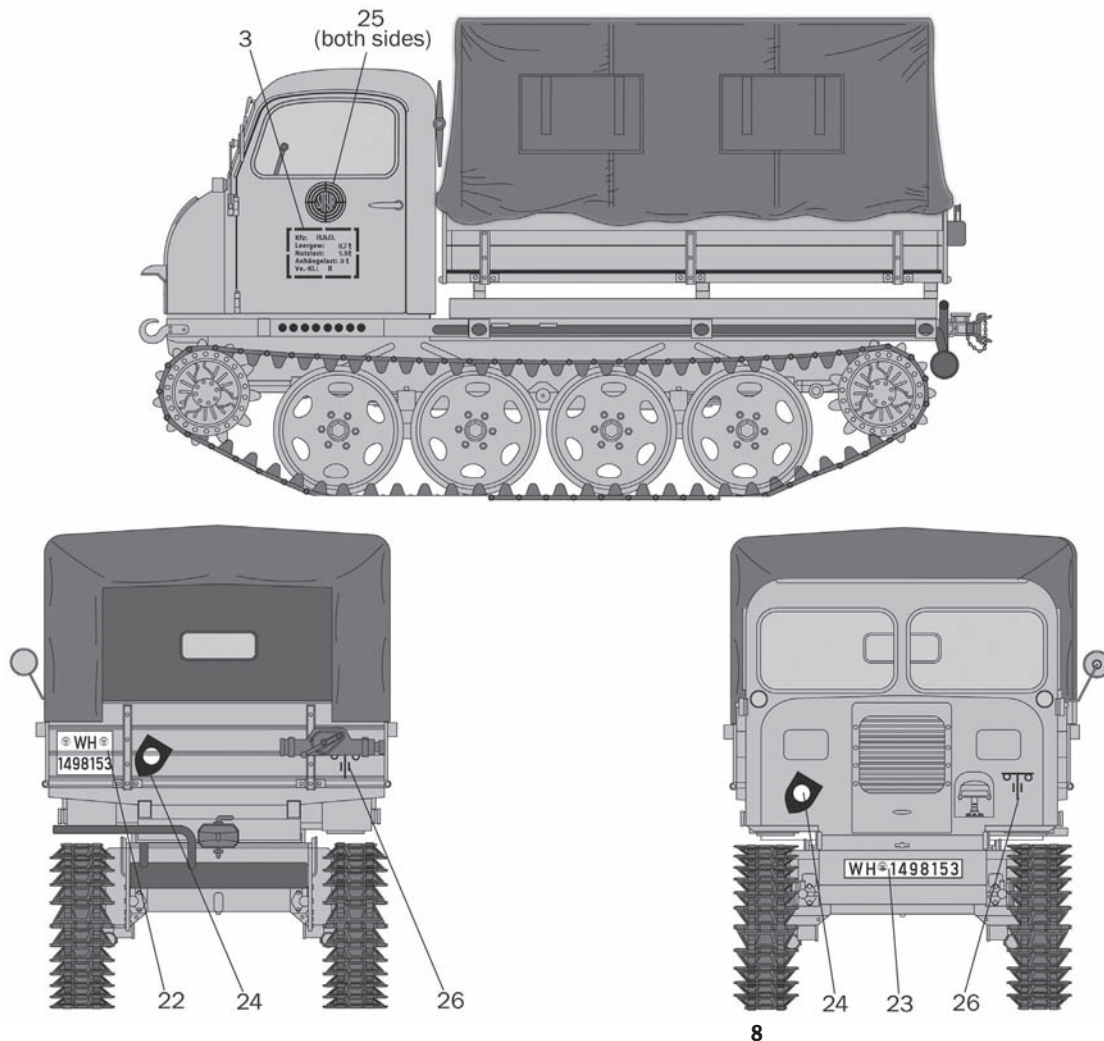

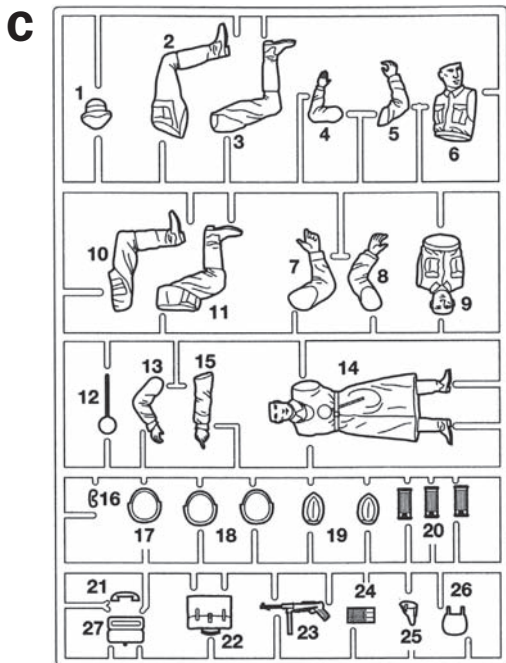
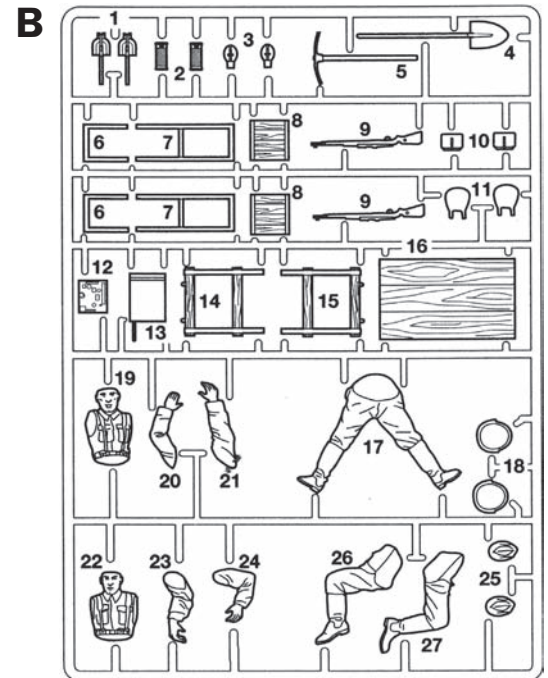
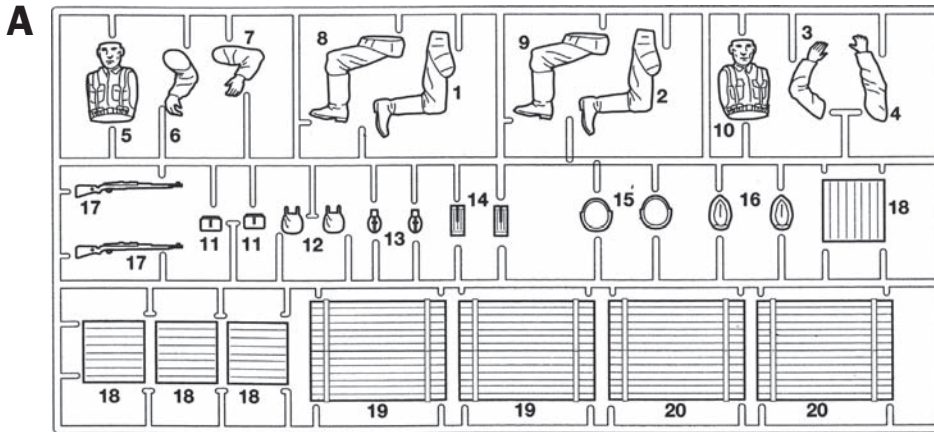

Color table

- | | |
|--|--|
| A FLAT BLACK
4768AP | H FLAT GUN METAL
4681AP |
| B FLAT SKIN TONE
4601AP | I FLAT BRUNO MIMETICO
4644AP |
| C FLAT GREEN
4862AP | L METAL. FLAT SILVER
4678AP |
| D FLAT WOOD
4673AP | M FLAT MEDIUM GREEN
4734AP |
| E FLAT Pz. SCHWARZGRAU RAL 7021
4795AP | N FLAT WHITE
4696AP |
| F FLAT BROWN
4858AP | O FLAT RED
4606AP |
| G FLAT LEATHER
4674AP | |

I numeri si riferiscono all'assortimento **Italeri Acrylic Paint**
 The indicated colour number refer to the **Italeri Acrylic Paint** range
 Les références indiquées concernent les peintures **Italeri Acrylic Paint**
 Die angegebenen farbnnummern beziehen sich auf die **Italeri Acrylic Paint**
 Los números se refieren a los colores surtido **Italeri Acrylic Paint**
 De nummers verwijzen naar het assortiment kleuren **Italeri Acrylic Paint**

MAP #1



MAP #2



MAP #3



MAGAZINE #1



MAGAZINE #2



1

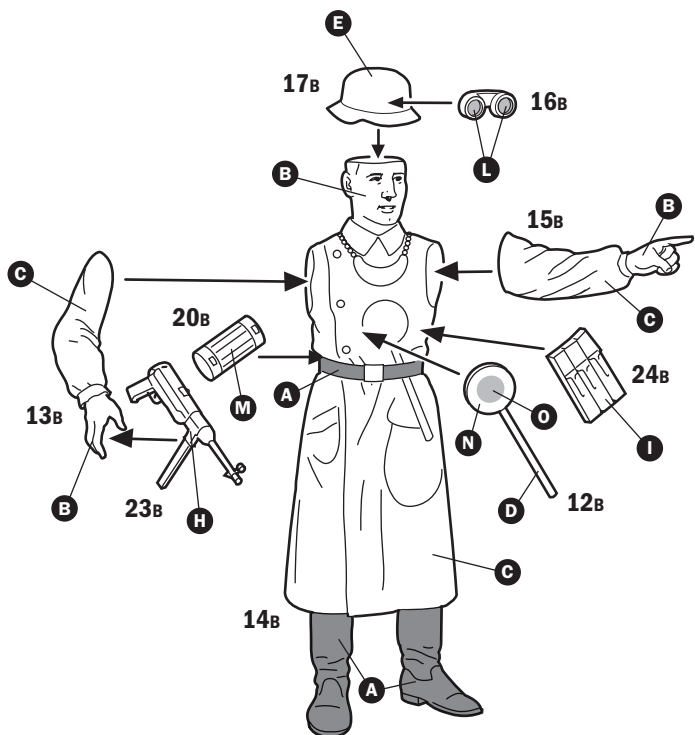
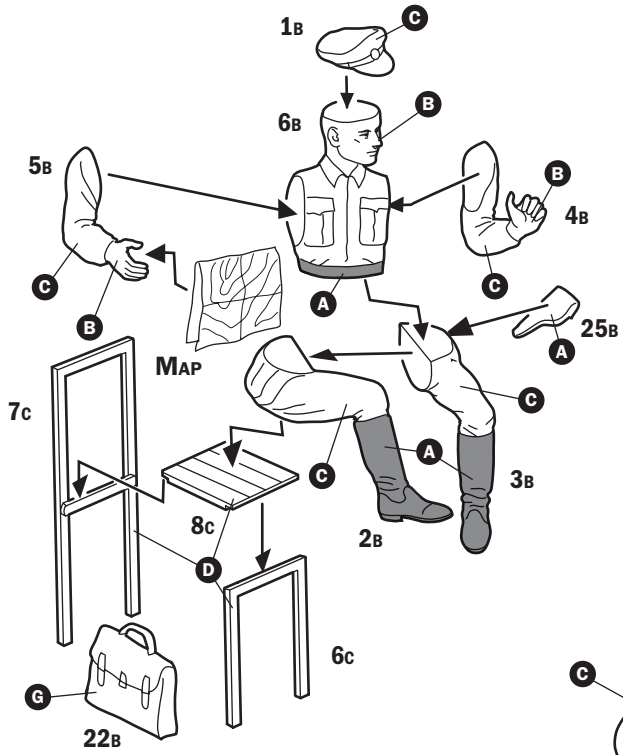
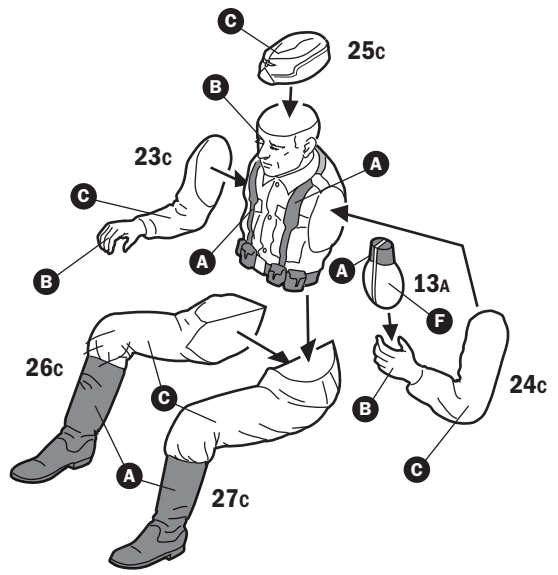
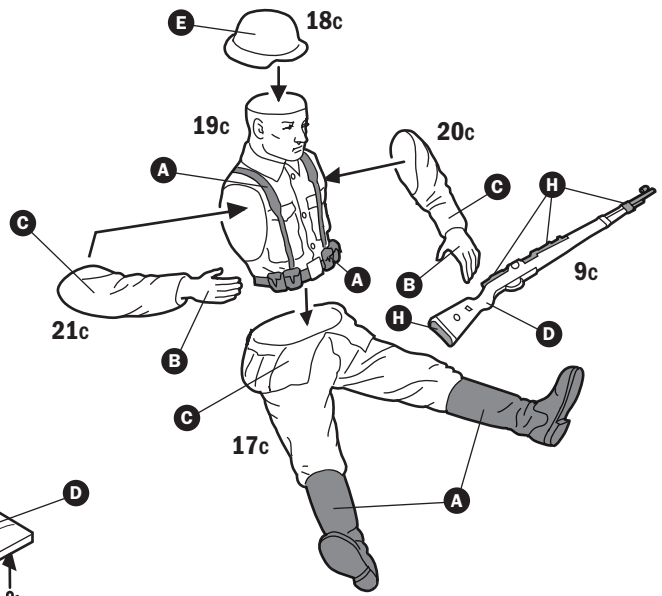
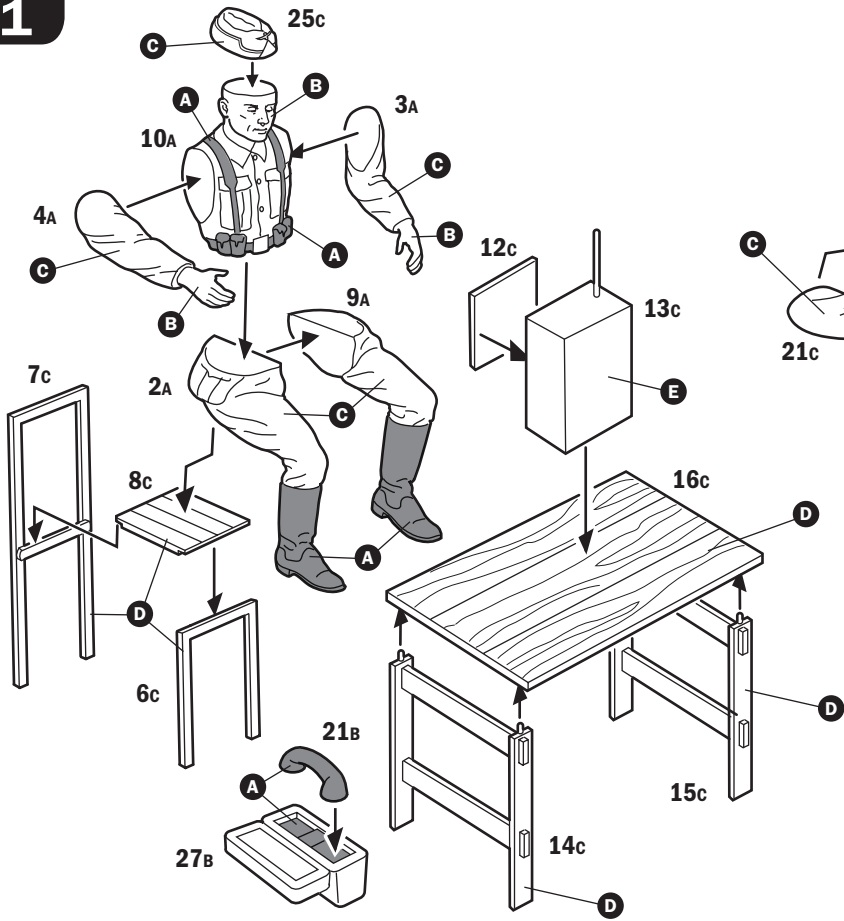

2

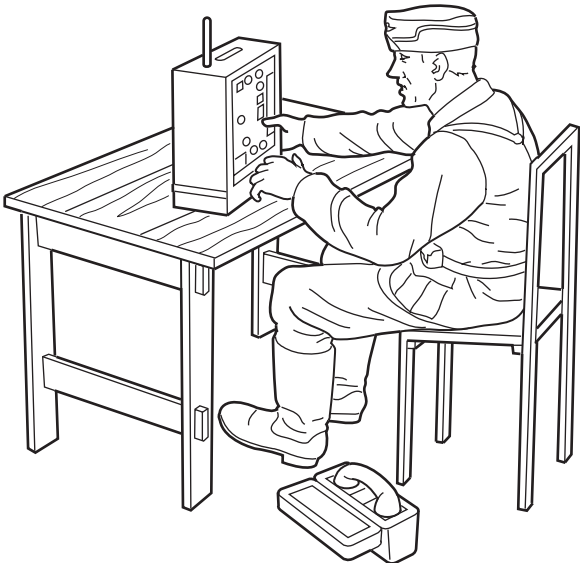
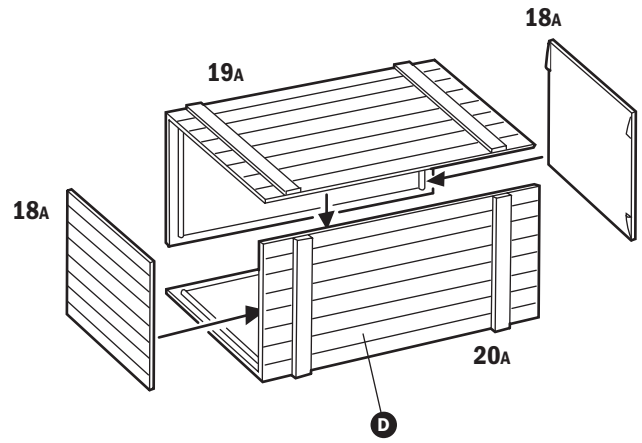
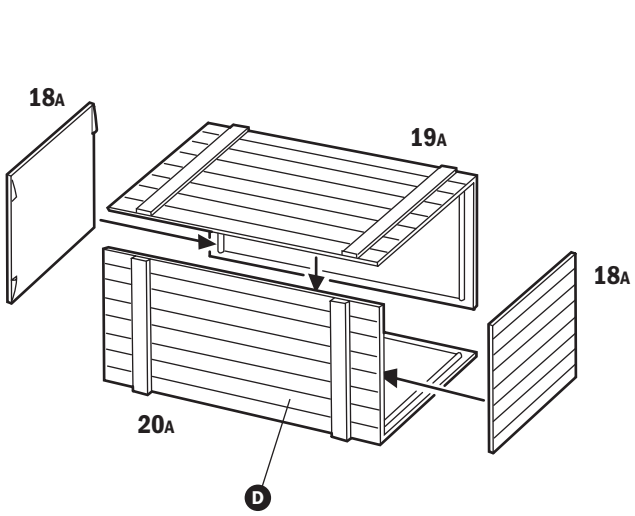
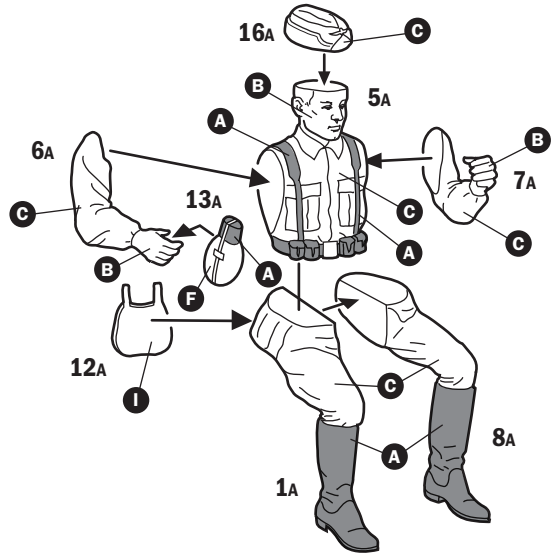
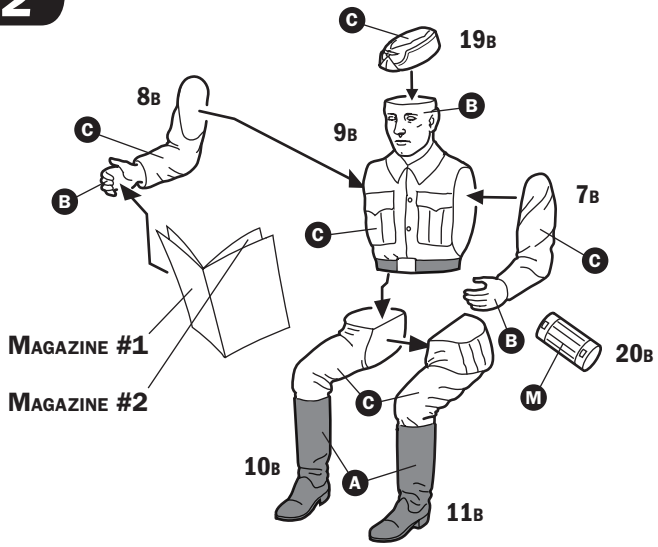

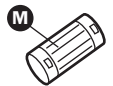
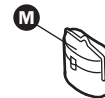
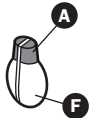
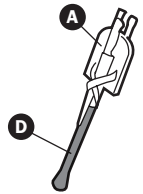
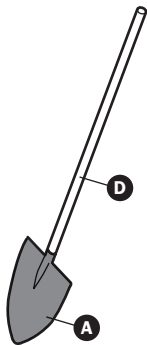
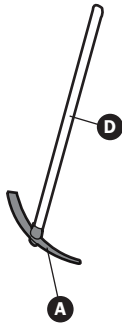
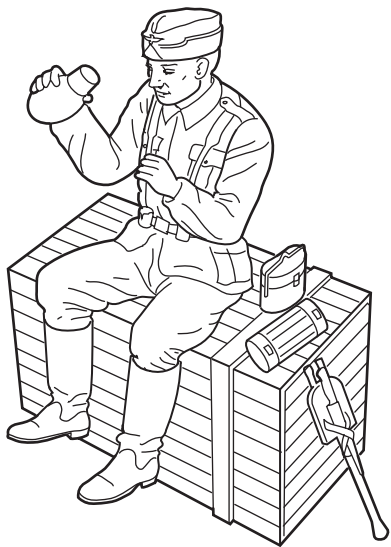

Kit No 6549 - 1:35 scale - Steyr RSO/01 with german soldiers and accessories

NAME
NOME
NAME
NOM
NOMBRE
NAAM

ADDRESS
INDIRIZZO
ADDRESS
ADRESSE
DIRECCION
ADRES

TOWN
CITTA'
STADT
VILLE
CIUDAD
GEMEENTE

POSTAL CODE
C.A.P.
POSTALEITZAHN
CODE POSTALE
CODIGO POSTAL
POSTCODE

COUNTRY
NAZIONE
LAND
PAYS
PAIS
LAND

DATE OF BIRTH
DATA DI NASCITA
GEBURTSDATUM
DATE DE NAISSANCE
NACIDO/A EL
GEBORTE DATUM

E-MAIL

PLACE OF PURCHASE
ACQUISTATO PRESSO
ORT DES KAUFES
LIEU D'ACHAT
LUGAR DE COMPRA
PLAATS VAN AANKOOP

DEFECTIVE PARTS
PARTI DIFETTOSI
DEFEKTE TEILE
PIECES DEFECTUEUSES
PIEZAS DEFECTUOSAS
DEFECTE ONDERDELEN

Retail Store
Negozio
Einzelhandel
Detaillant
Detaillista
Detailhandel

Hyper Market
Grande Magazzino
Andere
Grande Surface
Gran Almacén
Hypermarket

ITALERI S.p.A.
Via Pradazzo, 6/B
40012 - Calderara di Reno (BO) ITALY
fax: 0039 51 726 459
e-mail: italeri@italeri.com
www.italeri.com