



Via Pradazzo, 6/b
40012 Calderara di Reno
Bologna - Italy

Conservare il presente indirizzo per
futuro riferimento

Retain this address
for future reference

made in Italy

1:35 scale

No 6504

LMV Lince

We thank very much GMT (Gruppo Modellistico Trentino di studio e ricerca storica), editor of the Lince LMV – Light Multirole Vehicle book for the photographic material and for the technical documentation.



EN

The light multi-role vehicle LMV Lince, produced by the Italian manufacturer Iveco, was developed to have all the main features required to a light armoured vehicle of the latest generation. The independent front and rear suspension system is able to guarantee an excellent performance on all types of terrain and in any operating condition. The lay out of Lince is able to ensure a good protection level against light weapons fire. The frame structure, the armoured plates and the protection cell have been designed to deflect and absorb mine blast and explosion caused by more powerful weapons. The Lince is ideal as infantry mobility vehicle and it is able to perform properly reconnaissance and scout duties. Further more it has been developed to have a good versatility and it can be outfitted with several improvements. It is mainly adopted by Italian Army but, thanks to its features, it is having a good commercial success.

FR

Le véhicule léger multirôle LMV Lince, produit par l'entreprise italienne Iveco, a été développé pour synthétiser toutes les caractéristiques principales requises à un engin blindé léger de dernière génération. En effet, le système de suspensions avant et arrière indépendantes garantit une excellente performance sur tous types de sol et dans toutes conditions opérationnelles. La structure du Lince assure un bon niveau de protection contre le feu des armes légères et contre tout éclat. La structure de la cellule de sécurité interne et des plaques de renforcement réduit sensiblement les dommages produits par les mines ou par des explosions plus puissantes. Le Lince se présente donc comme un engin idéal pour effectuer des missions d'exploration, desserte et transport tactique de troupes. Par ailleurs, il a été développé pour présenter une grande polyvalence d'utilisation ainsi qu'une facilité d'installation. Employé principalement par l'Armée Italienne, il a reçu un bon succès commercial dans différents Pays.

IT

Il veicolo leggero multiruolo LMV Lince, prodotto dall'azienda italiana Iveco, è stato sviluppato per sintetizzare tutte le principali caratteristiche che si richiedono ad un mezzo blindato leggero di ultima generazione. Il sistema di sospensioni anteriori e posteriori indipendenti garantisce infatti un'ottima performance su tutte le tipologie di terreno e in ogni condizione operativa. La struttura del Lince è in grado di garantire un buon livello di protezione dal fuoco delle armi leggere e dalle schegge. La struttura della cellula di sicurezza interna e delle piastre di rinforzo riduce sensibilmente i danni prodotti dalle mine o da esplosioni più potenti. Il Lince si presenta quindi come mezzo ideale per compiti di esplorazione, collegamento e trasporto tattico di truppe. E' stato inoltre sviluppato per avere una versatilità di impiego e una facile allestibilità. Impiegato prevalentemente dall'Esercito Italiano, ha avuto un buon successo commerciale in diversi Paesi.

ES

El vehículo ligero polivalente LMV Lince producido por la empresa italiana Iveco, ha sido desarrollado para unir todas las principales características que se exigen a un medio blindado ligero de última generación. El sistema de suspensiones delanteras y posteriores independientes garantiza, de hecho, una prestación óptima en cualquier tipo de terreno y en cualquier condición operativa. La estructura del Lince es capaz de garantizar un buen nivel de protección contra el fuego de las armas ligeras y contra la metralla. La estructura de la célula de seguridad interna y de las placas de refuerzo reduce notablemente los daños producidos por las minas o por explosiones más potentes. El Lince se presenta, por lo tanto, como un medio ideal para tareas de exploración, conexión y transporte táctico de tropas. Además, ha sido diseñado para ser versátil en el uso y para ser equipado fácilmente. Ha sido utilizado sobre todo por el Ejército Italiano, y ha tenido un buen éxito comercial en varios países.

DE

Das leichte und multifunktionale Militärfahrzeug LMV Lince wurde vom italienischen Unternehmen Iveco hergestellt und entwickelt, um die wichtigsten Eigenschaften, die von einem leichten Panzerfahrzeug der letzten Generation gefordert werden, zu vereinen. Das System der unabhängigen Vorder- und Hinteradaufhängung garantiert beste Leistung auf jeder Geländeart und unter jeder Einsatzbedingung. Seine Beschaffung garantiert einen guten Schutzgrad gegen Beschuss durch leichte Waffen und gegen Splitter. Die Struktur der inneren Sicherheitszelle und der Panzerplatten setzt die durch Minen oder durch heftige Explosionen hervorgerufenen Schäden deutlich herab. Der Lince präsentiert sich aus diesem Grund als ideales Einsatzfahrzeug für Erkundungseinsätze, Verbindungsfahrten und taktischen Truppentransport. Er wurde des Weiteren für einen vielseitigen Einsatz und eine einfache Ausstattungsmöglichkeit entwickelt. Sein Einsatz war vorwiegend bei den italienischen Streitkräften, er konnte jedoch guten kommerziellen Erfolg in verschiedenen Ländern erzielen.

RU

Легкая многоцелевая бронемашина LMV Lince, производимая итальянской компанией Iveco, разработана с целью сочетания в единой машине всех основных характеристик легкой бронетехники последнего поколения. Система независимых передних и задних подвесок обеспечивает превосходные показатели на любой местности и в любых рабочих условиях. Конструкция Lince может обеспечить хороший уровень защиты от огня из легкого оружия и осколков. Конструкция внутреннего защитного отсека и укрепляющих пластин значительно сокращает ущерб, наносимый минами или более сильными взрывами. Lince представляет собой идеальное средство для разведки, связи и тактической транспортировки войск. Кроме того, эта машина была разработана для универсальности использования и простоты оснащения. Преимущественно ей пользуются Итальянские вооруженные силы, но и в других странах эта машина пользуется успехом.

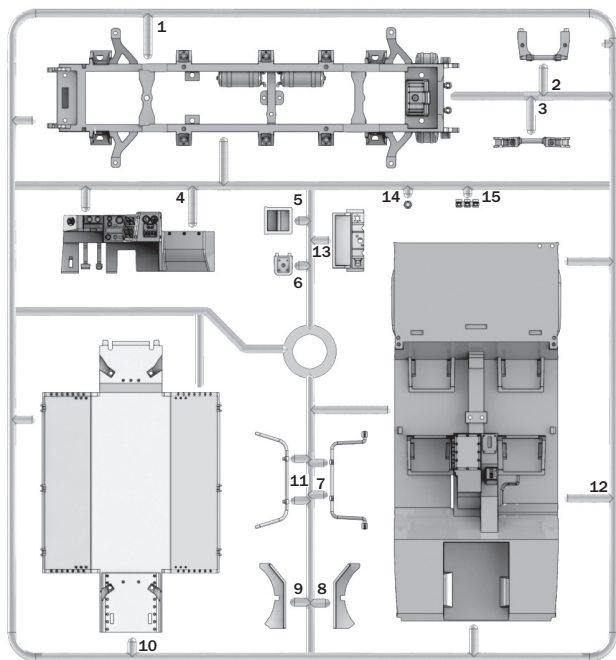
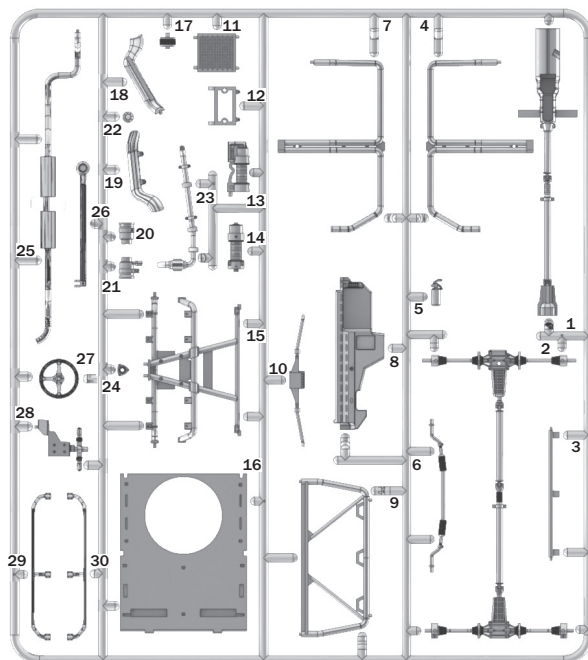
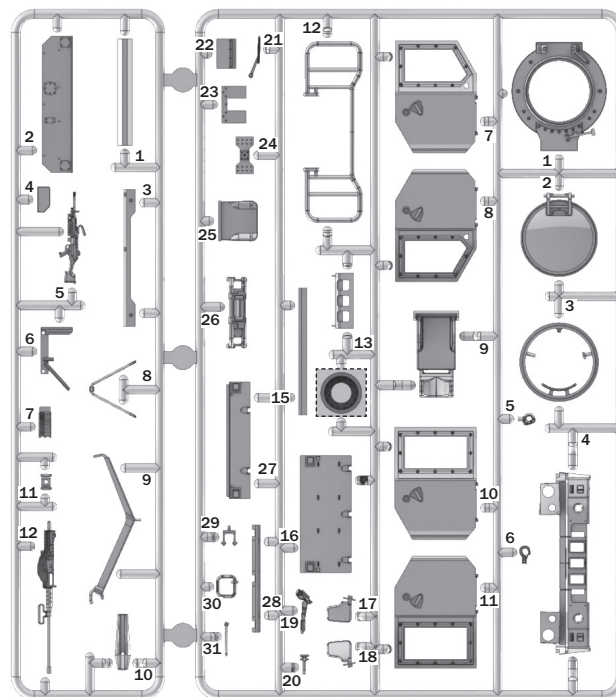
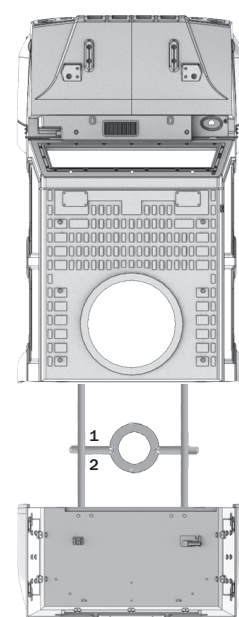
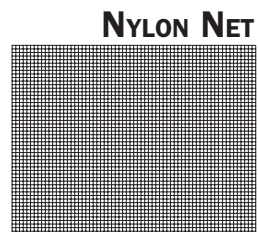
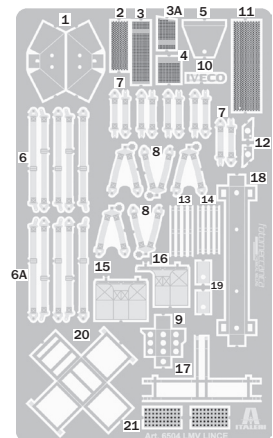

- EN** **WARNING:** Model for adult collector age 14 and over
- IT** **ATTENZIONE:** Modello per collezionisti adulti di età superiore ai 14 anni
- FR** **ATTENTION:** Modèle pour modélistes de 14 ans et plus.
- DE** **ACHTUNG:** Modellbausätze Für Modellbauer über 14 Jahre.
- NL** **WAARSCHWING:** Geschikt voor 14 jaar en ouder.
- ES** **ATENCION:** Modelo para modelistas mayores de 14 años.

**A****B****D****C****F****NYLON NET****PE**

Parti da non utilizzare
 Parts not for use
 Pièces à ne pas utiliser
 Teile werden nicht verwenden
 Partes a no utilizar
 Onderdelen niet te gebruiken



Drill holes
 Die Locher Ausbohren
 Aprire i fori
 Ouvrir les trous
 Perforar los agujeros
 Open gaten



Cut
 Entfernen
 Separare
 Retirer
 Separar
 Gesneden

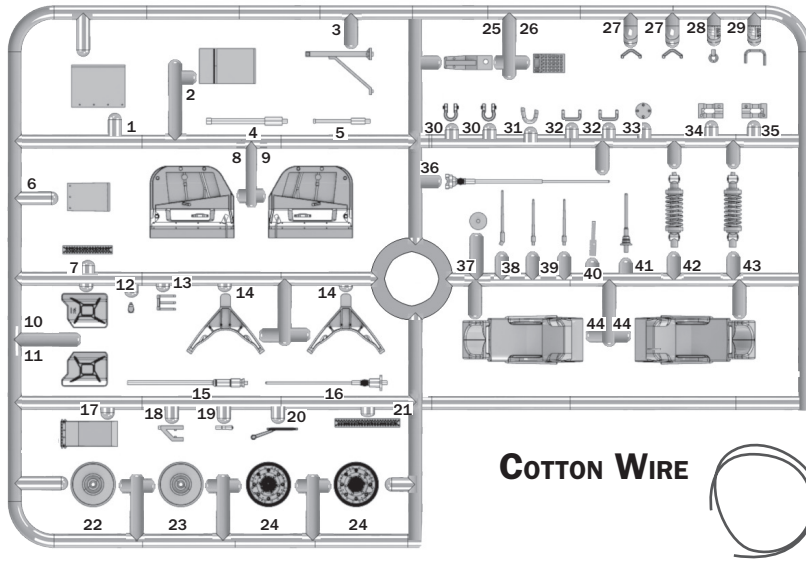
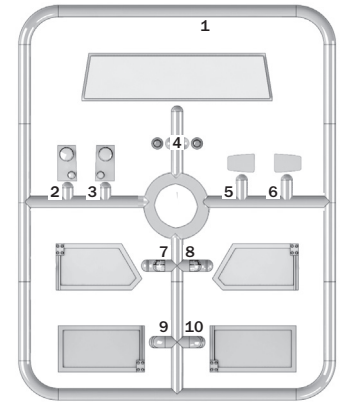
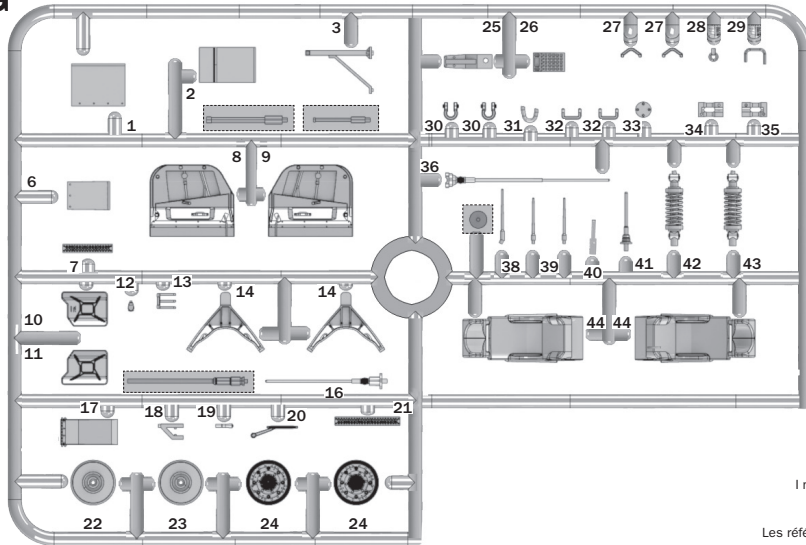
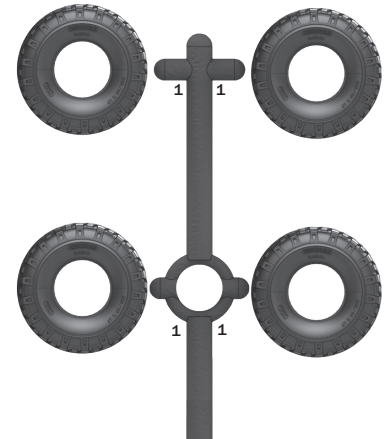

**G****H****G****I**

I numeri si riferiscono all'assortimento colori Model Master /Italeri Acrylic Paint
 The indicated colour number refer to the Model Master /Italeri Acrylic Paint
 Les références indiquées concernent les peintures Model Master /Italeri Acrylic Paint
 Die angegebenen farbnnummern beziehen sich auf die Model Master /Italeri Acrylic Paint
 Los números se refieren a los colores surtido Model Master /Italeri Acrylic Paint
 De nummers verwijzen naar het assortiment kleuren Model Master /Italeri Acrylic Paint

A

FLAT BLACK
 F.S. 37038
 Italeri 4768AP

B

METAL FLAT ALUMINIUM
 F.S. 37178
 Italeri 4677AP

C

FLAT RUST
 F.S. 30109
 Italeri 4675AP

D

FLAT GREEN 383
 F.S. 34094
 Italeri 4857AP

E

GLOSS RED
 F.S. 11302
 Italeri 4605AP

F

FLAT WHITE
 F.S. 37875
 Italeri 4769AP

H

METAL FLAT STEEL
 F.S. 37178
 Italeri 4679AP

J

FLAT FIELD DRAB
 F.S. 30118
 Italeri 4708AP

K

FLAT ORANGE
 F.S. 32197
 Italeri 4302AP

L

FLAT GUN METAL
 F.S. 37200
 Italeri 4681AP

L

FLAT WOOD
 F.S. 30257
 Italeri 4673AP

M

METAL GLOSS BRASS
 Italeri 4672AP



EN ATTENTION - Useful advice!

Study the instructions carefully prior to assembly. Remove parts from frame with a sharp knife or a pair of scissor and trim away excess plastic. Do not pull of parts. Assemble the parts in numerical sequence. Use plastic cement ONLY and use cement sparingly to avoid damaging the model. Black arrows indicate parts to be glued together. White arrows indicate on which frame the parts must be assembled WITHOUT using cement. These letters (A - B - C...) indicate on which frame the parts will be found. Paint small parts before detaching them from frame. Remove paint-where parts are to be cemented. Crossed out parts must not be used.

IT ATTENZIONE - Consigli utili!

Prima di iniziare il montaggio studiare attentamente il disegno. Staccare con molta cura i pezzi dalle stampate, usando un taglia-balsa oppure un paio di forbici e togliere con una piccola lima o con carta vetro fine eventuali sbavature. Mai staccare i pezzi con le mani. Montarli seguendo l'ordine delle numerazione delle tavole. Eliminare dalla stampata il numero del pezzo appena montato facendogli sopra una croce. Le frecce nere indicano i pezzi da incollare, le frecce bianche indicano i pezzi da montare senza colla. Usare solo colla per polistirolo. Le lettere (A - B - C...) ai lati dei numeri indicano la stampata ove si trova il pezzo da montare. I pezzi sbarrati da una croce non sono da utilizzare.

DE ACHTUNG - Ein nützlicher Rat!

Vor der Montage die Zeichnung aufmerksam studieren. Die einzelnen Montageteile mit einem Messer oder einer Schere vom Spritzling sorgfältig entfernen. Eventuelle Grate werden mit einer Klinge oder feinem Schmirgelpapier beseitigt. Keinesfalls die Montageteile mit den Händen entfernen. Bei der Montage der Tafelnummerierung folgen. Pfeile zeigen die zu klebenden Teile während die weissen Pfeile die ohne Leim zu montierenden Teile anzeigen. Bitte nur Plastikklebstoff verwenden. Die Buchstaben (A - B - C...) neben den Nummern zeigt, auf welchem Spritzling der zu montierende Teil zu finden ist. Die mit einem Kreuz markierten Teile sind nicht zu verwenden.

FR ATTENTION - Conseils utiles!

Avant de commencer le montage, étudier attentivement le dessin. Détacher avec beaucoup de soin les morceaux des moules en usant un massicot ou bien un pair de ciseaux et couper avec une petite lame avec de papier de verre fin ébarbages éventuels. Jamais détacher les morceaux avec le mains Monter les en suivant l'ordre de la numération des tables. Eliminer de la moule le numéro de la pièce qui vient d'être montée, en le bifant avec une croix. Les flèches noires indiquent les pièces à coller, les flèches blanches indiquent les pièces à monter sans colle. Employer seulement de la colle pour polystyrol. Les lettres (A - B - C...) aux côtés des numéros indiquent la moule où se trouve la pièces a monter. Les pièces marquées par une croix ne sont pas a utiliser.

NL OPGELET - Belangrijke bemerkingen!

Bestudeer zorgvuldig het montageplan voor het bouwen. Breek nooit onderdelen van het kader. Maak ze los met een scherp mes of kleine nageltang. Verwijder daarna al het overtollige plastic en pas de delen alvoreens te lijmen. Gebruik allen lijm voor plastic modellen. Werk zorgvuldig en spaarzaam, teveel lijm zal uw model beschadigen. Zwarte pijlen duiden de te lijmen delen aan. Witte pijlen verwijzen naar bewegende delen welke niet mogen worden gelijmd. Deze letters (A - B - C...) geven de kaders aan waarin de onderdelen zich bevinden. Schilder de kleine onderdelen voor ze van het kader te snijden. Verwijder de verf van de te lijmen oppervlakten.

ES ATENCION - Consejos útiles!

Estudiar las instrucciones cuidadosamente antes de comenzar el montaje. Separar las piezas de las bandejas con un cuchillo afilado o un par de tijeras y retirar el exceso de plástico o rebada. No arrancar las piezas. Montar las piezas en orden numérico. Utilizar SOLAMENTE pegamento para plástico y en poca cantidad para evitar que se dane el modelo. Las flechas negras indican las piezas que se deben pegar juntas. Las flechas blancas indican las piezas que deben ensamblarse SIN usar pegamento. Las letras (A - B - C...) indican en que bandeja se encuentran las piezas. Pintar las piezas pequeñas antes de separarlas de la bandeja. Retirar la pintura de los lugares por donde se deban pegar las piezas.

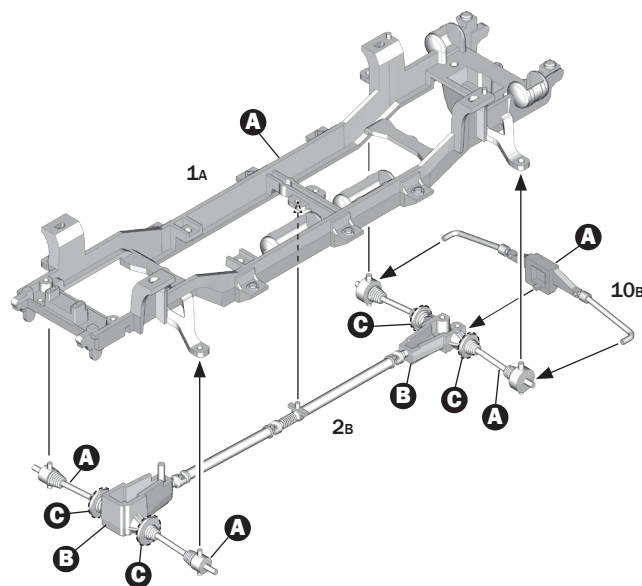
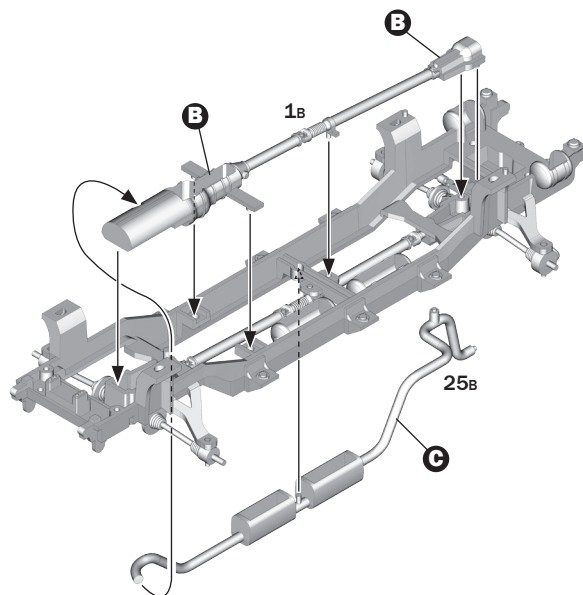
1**2**



3

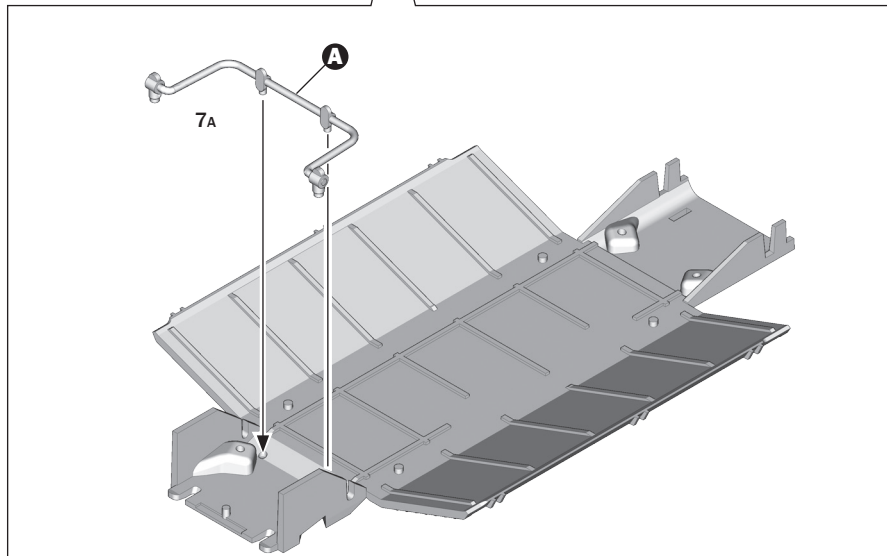
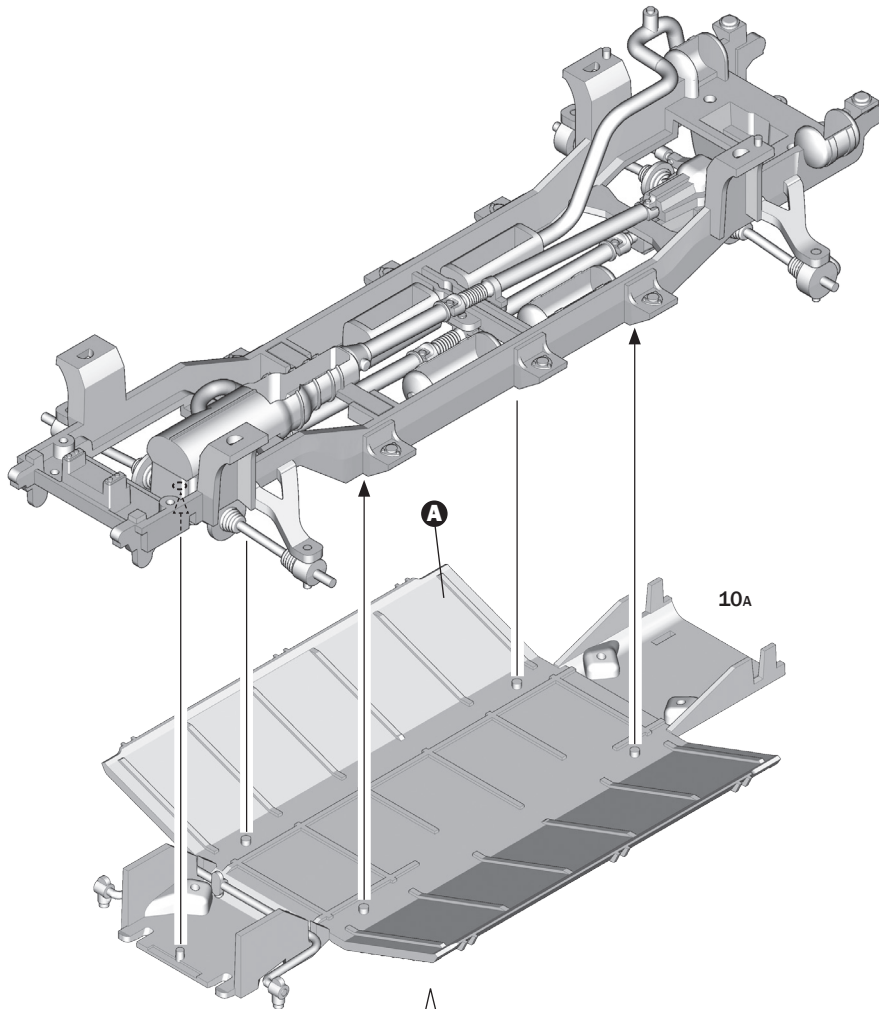

4

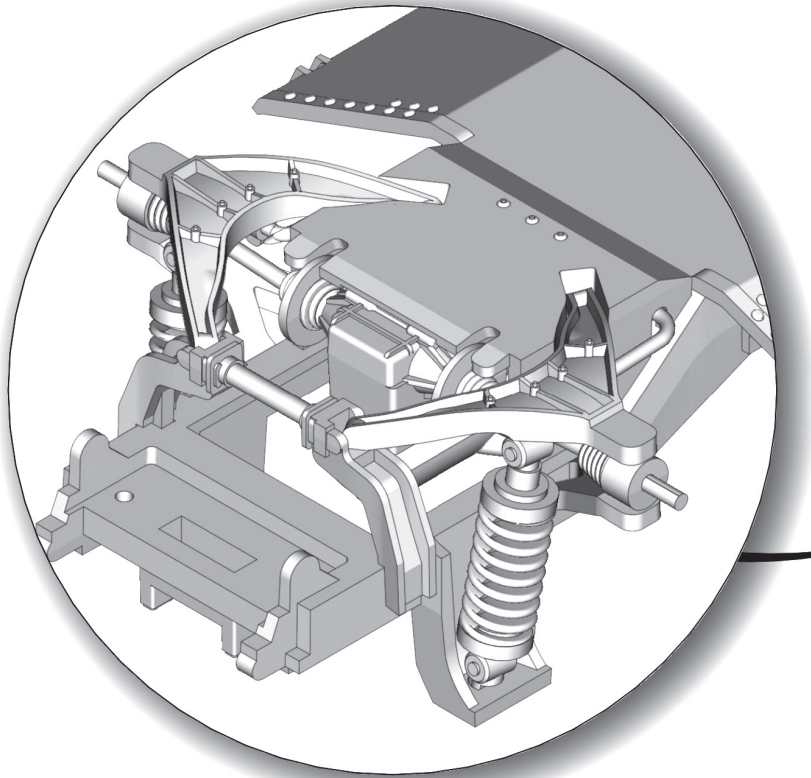
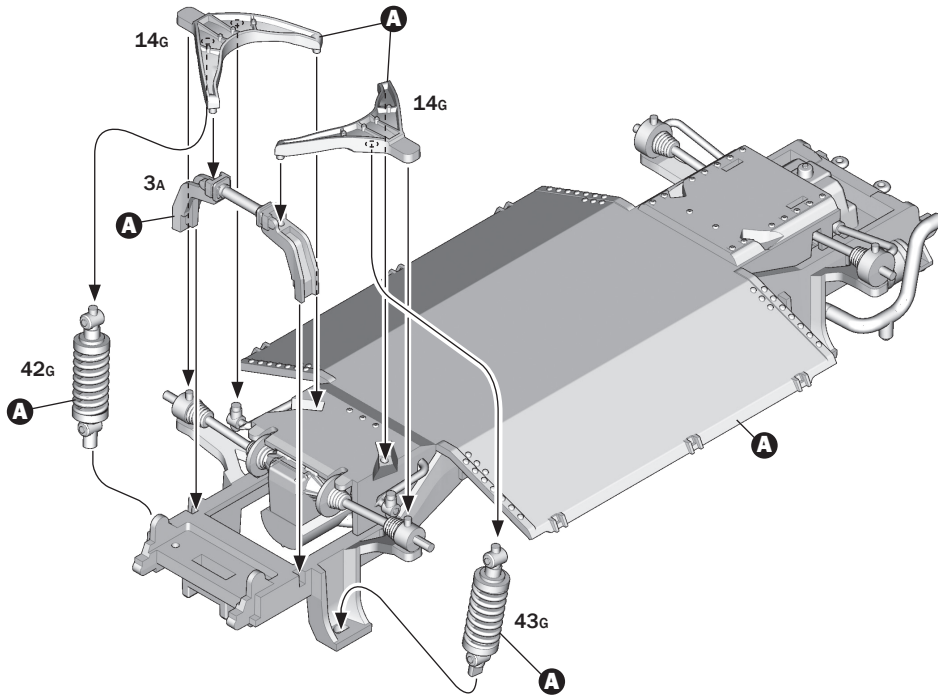

DETAILED VIEW

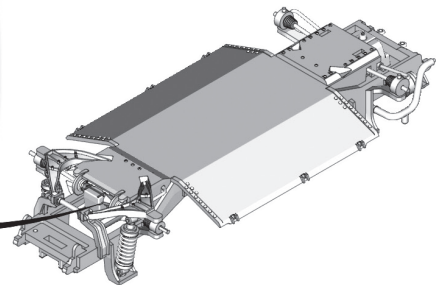

5

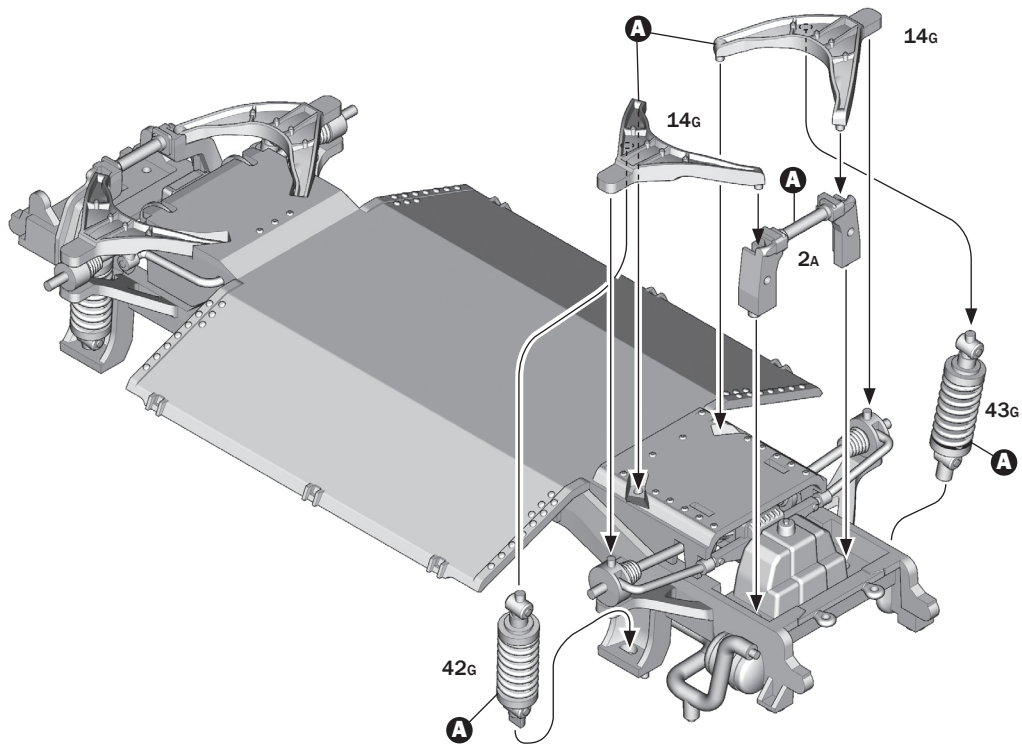

DETAILED VIEW

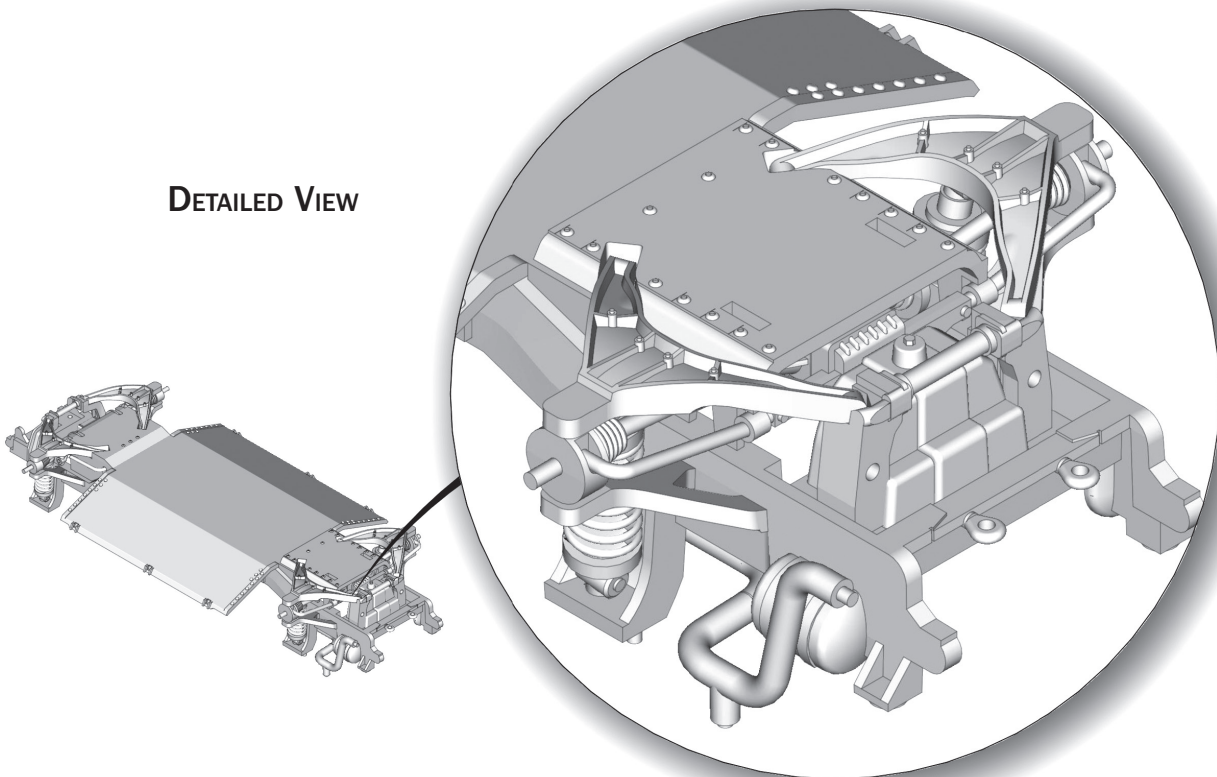

6

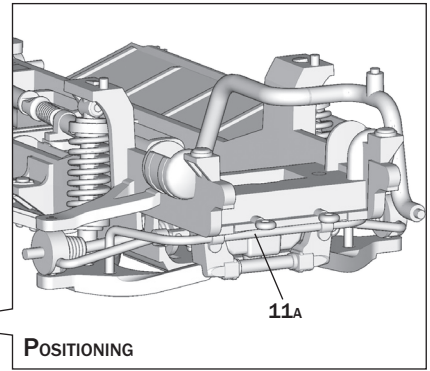
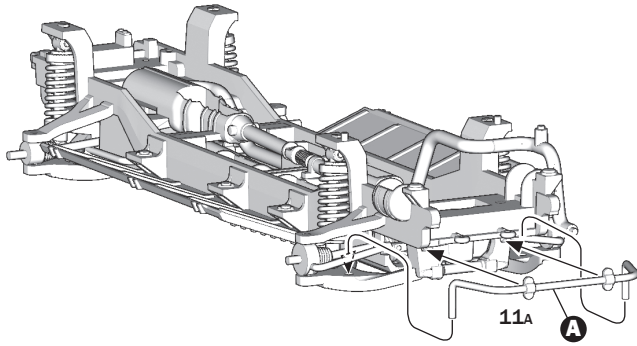

7

A 2x

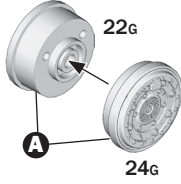

B 2x

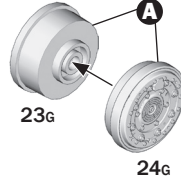

A

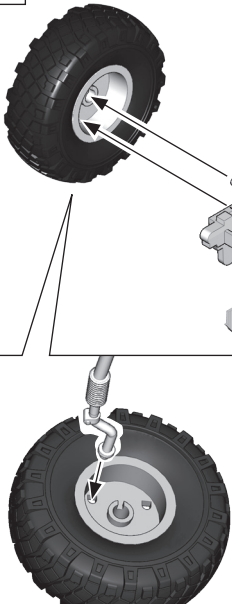

B



B



13c

A

6B

A



8

C

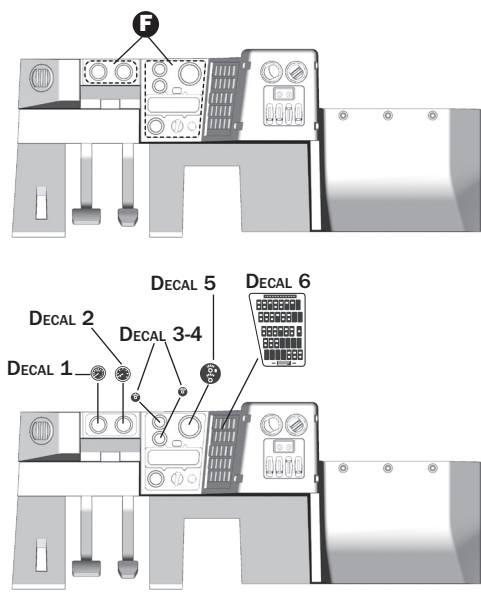
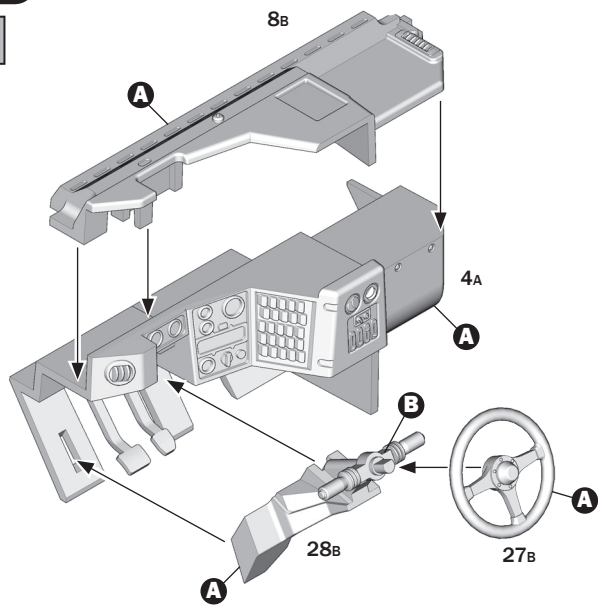

9

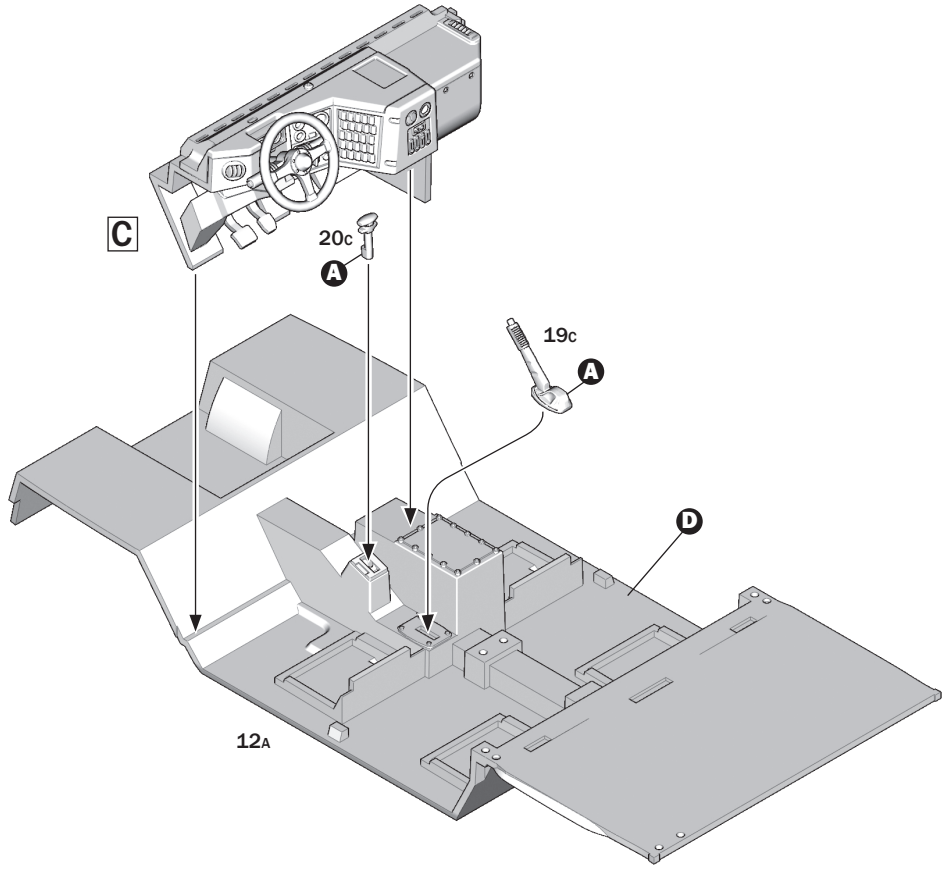



10

D 4x

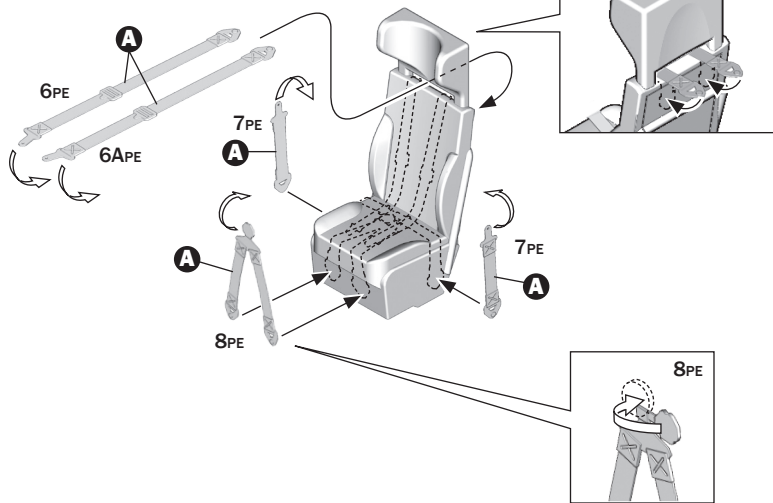
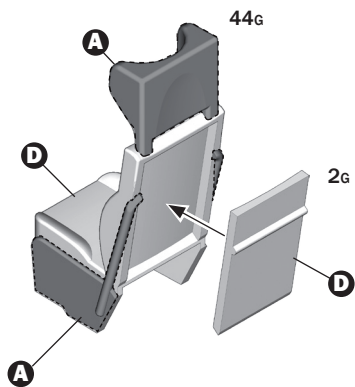

11

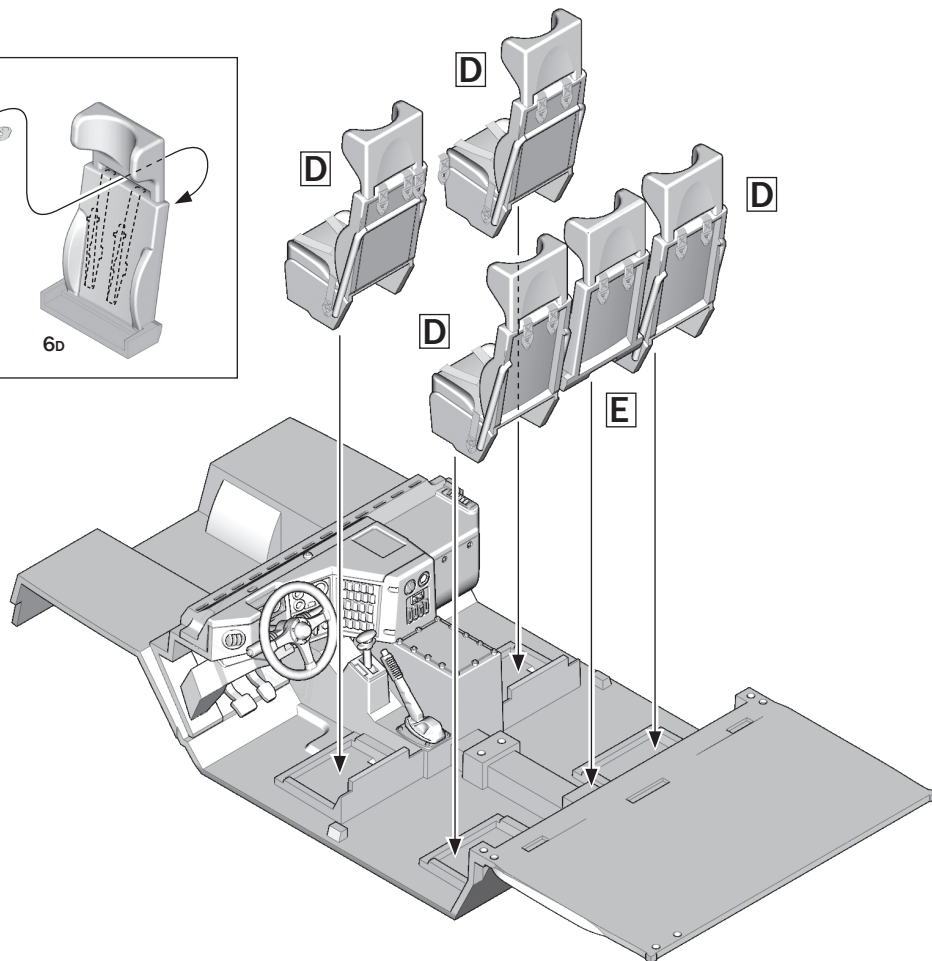
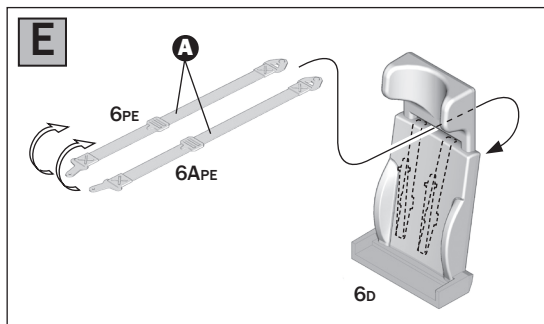



12

F

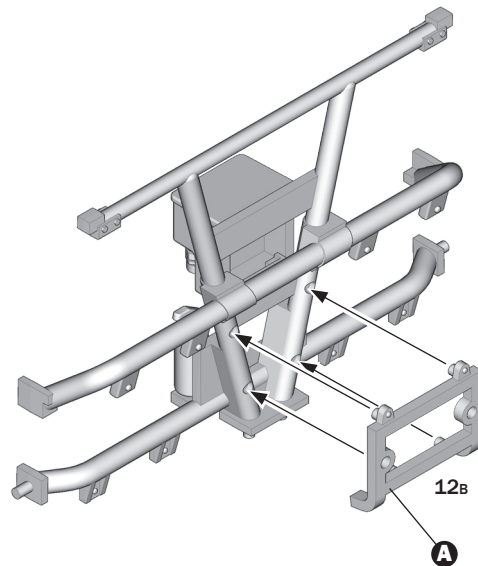
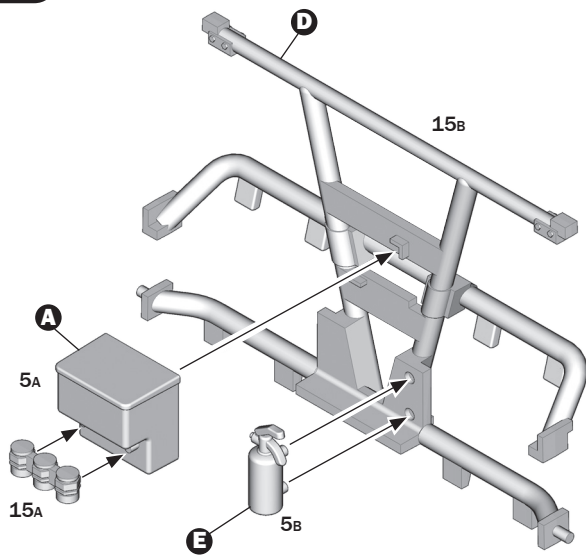

13

F

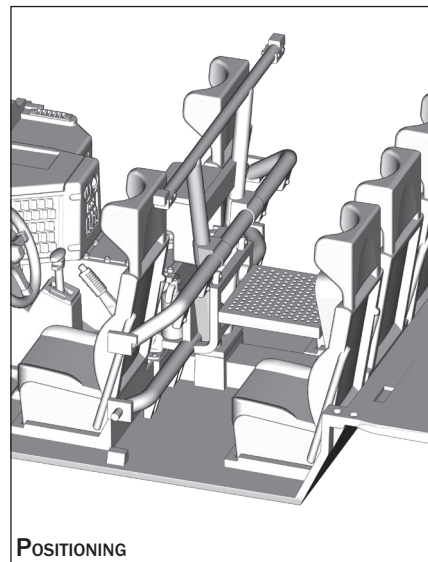
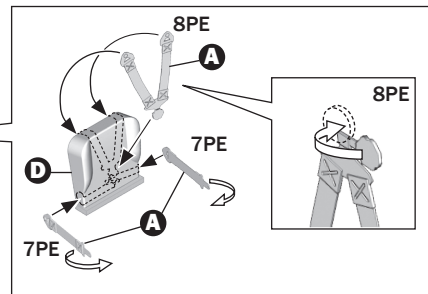
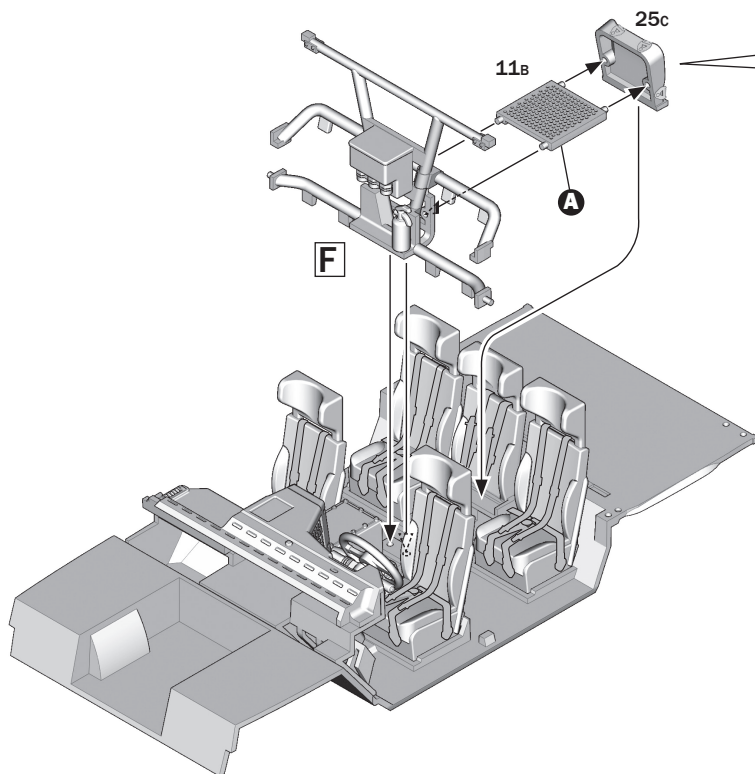

POSITIONING





14

G

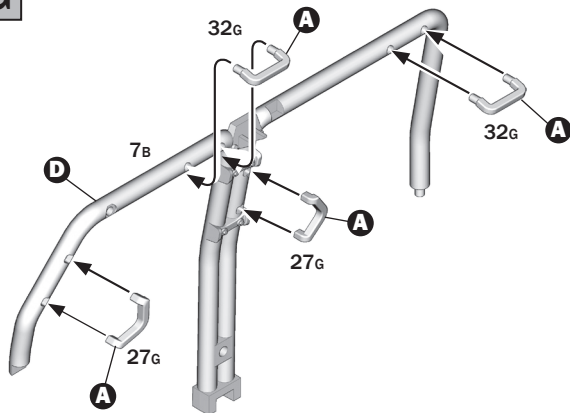

H

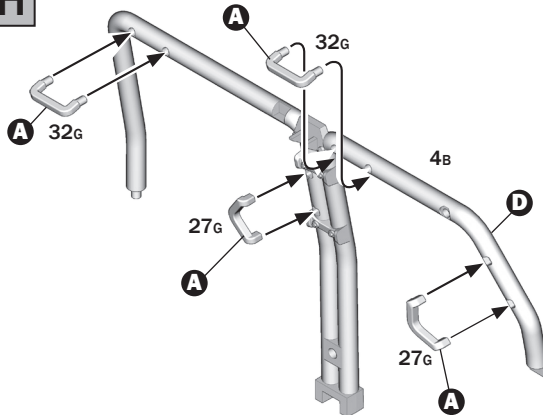

15

I

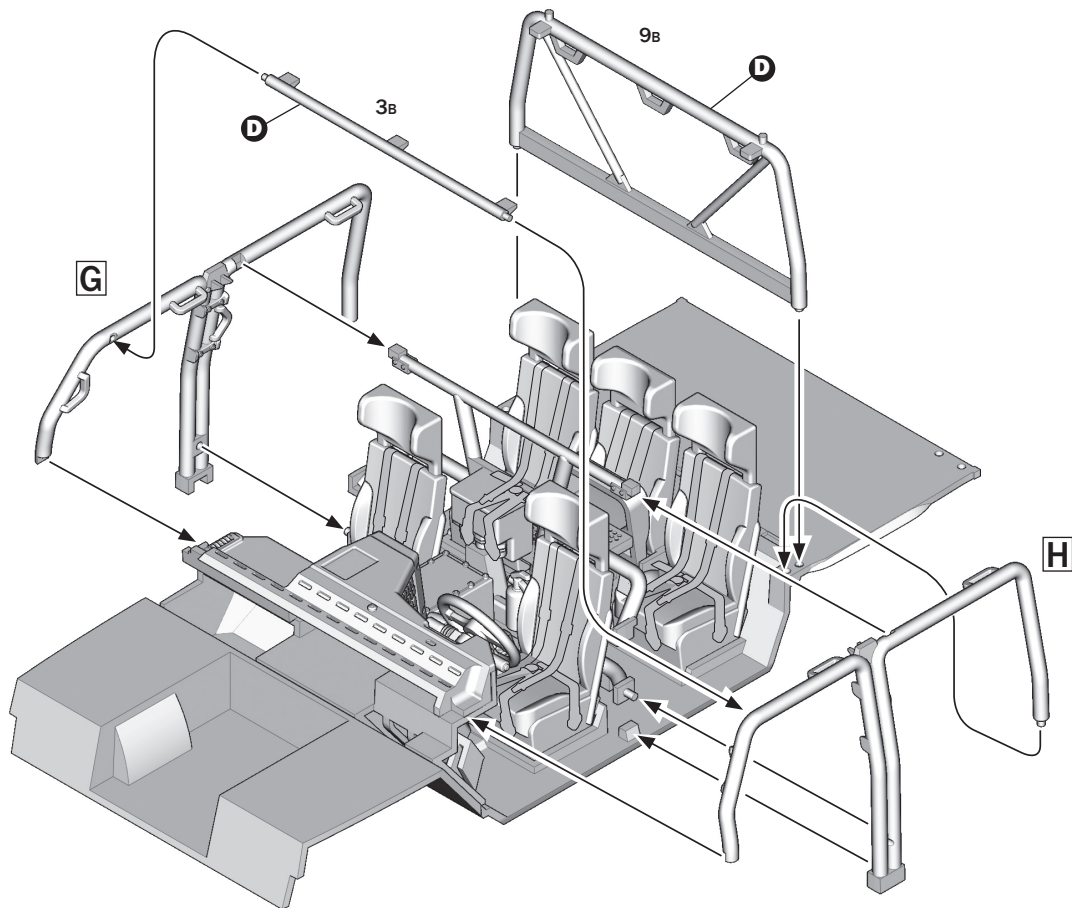

16

L

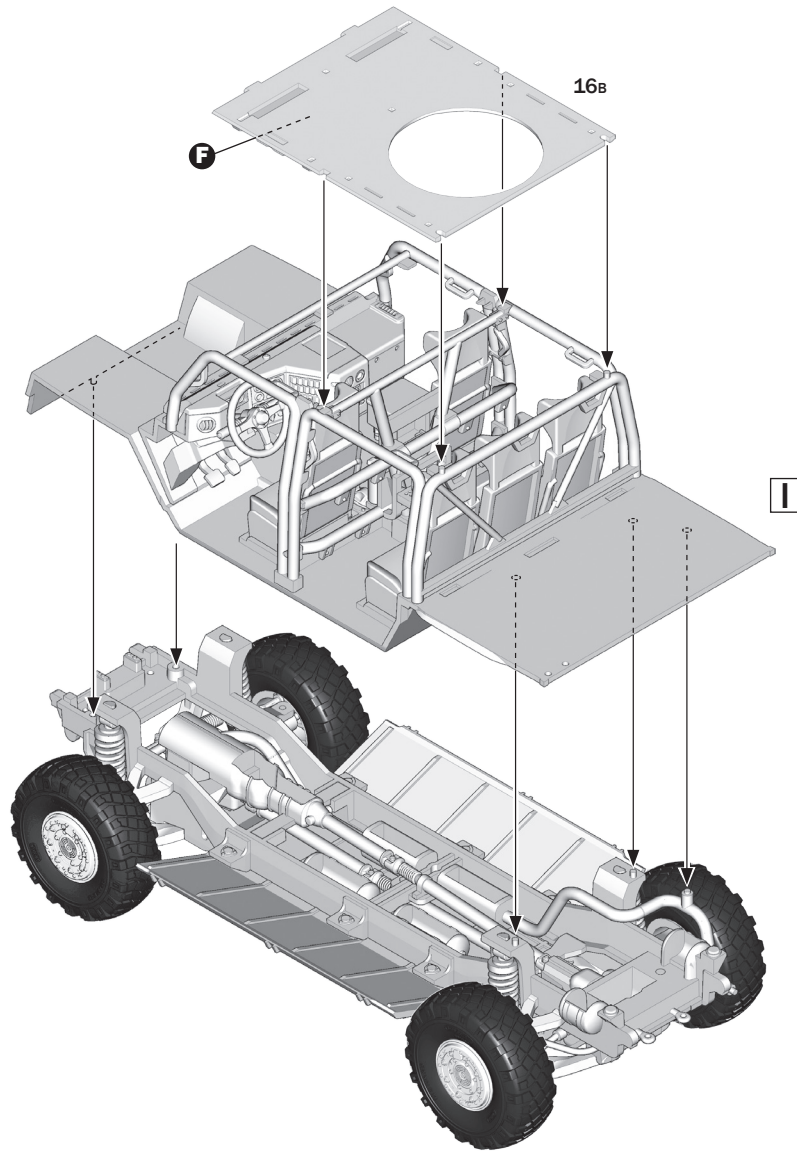

17

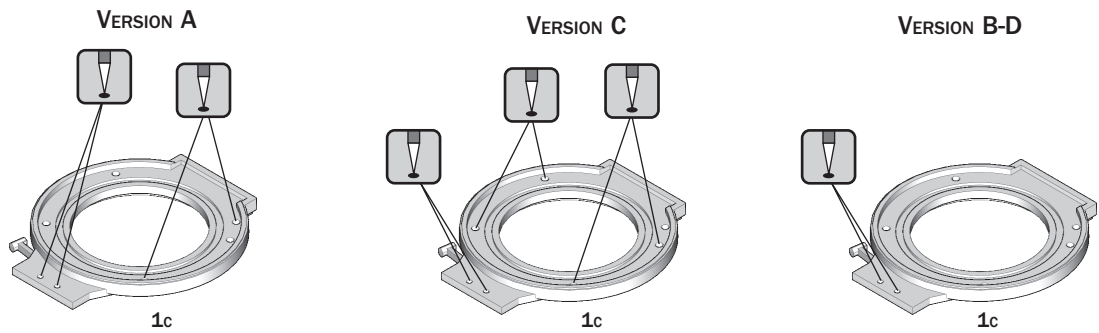



18

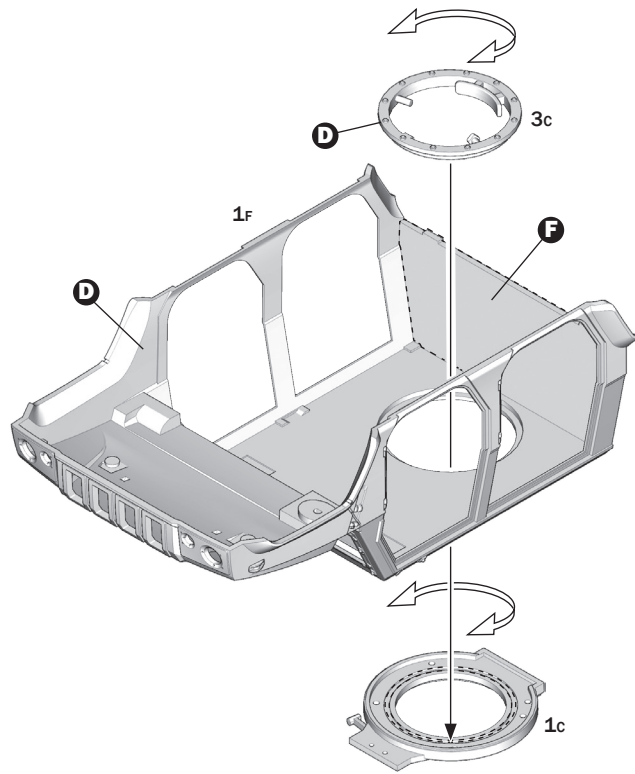
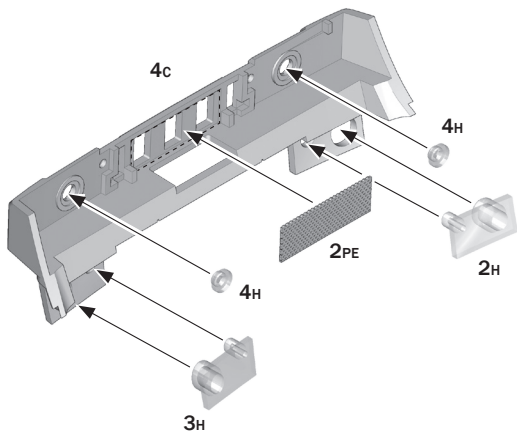

19

M

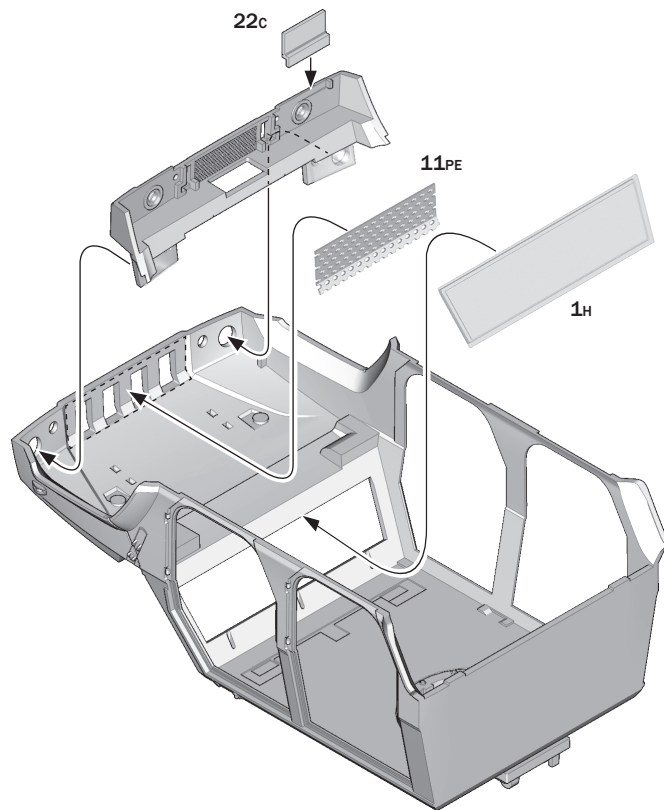
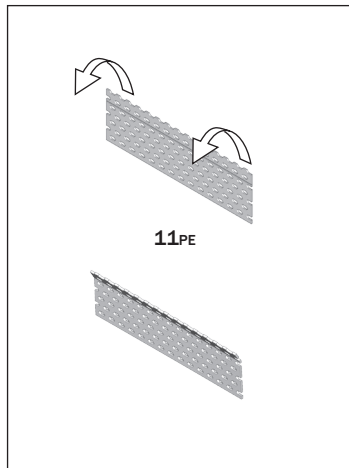

20

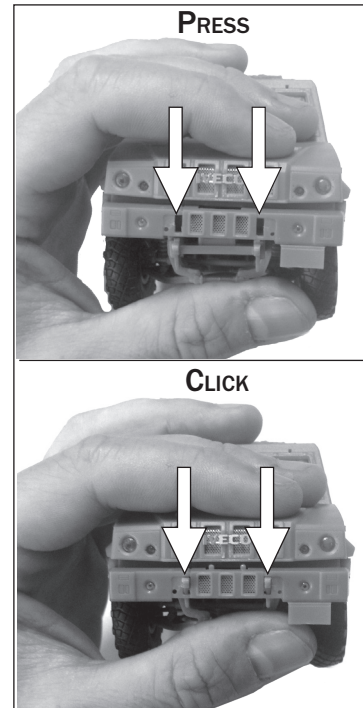
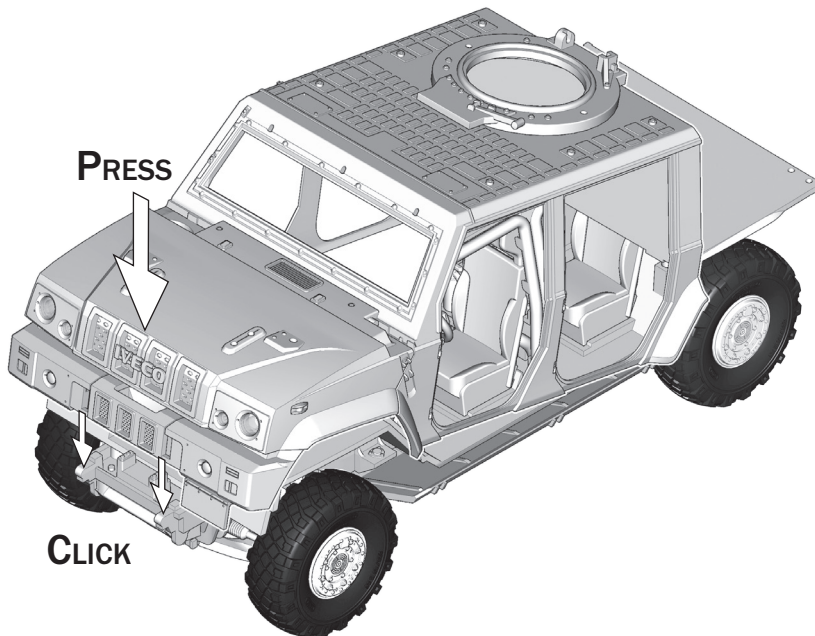
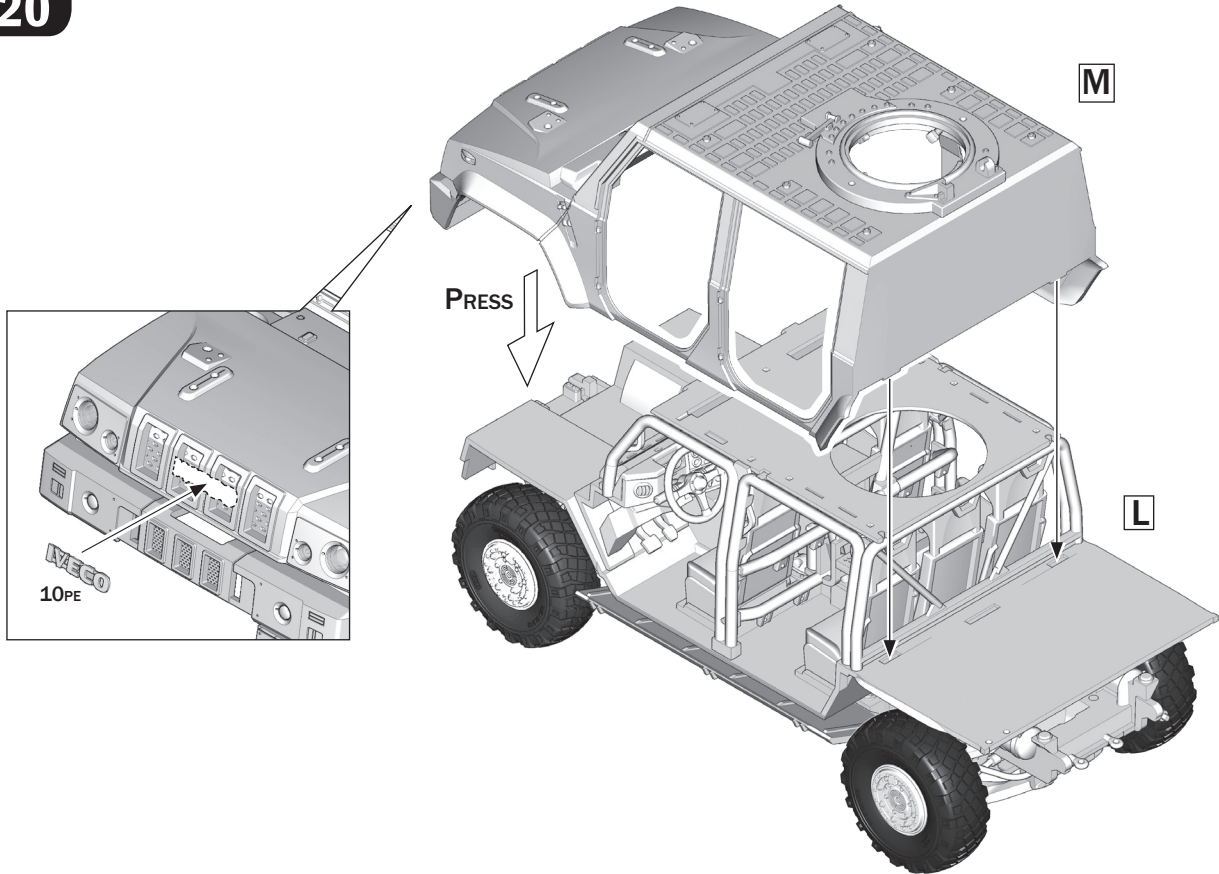

21

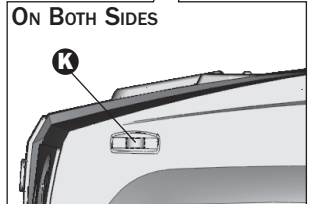
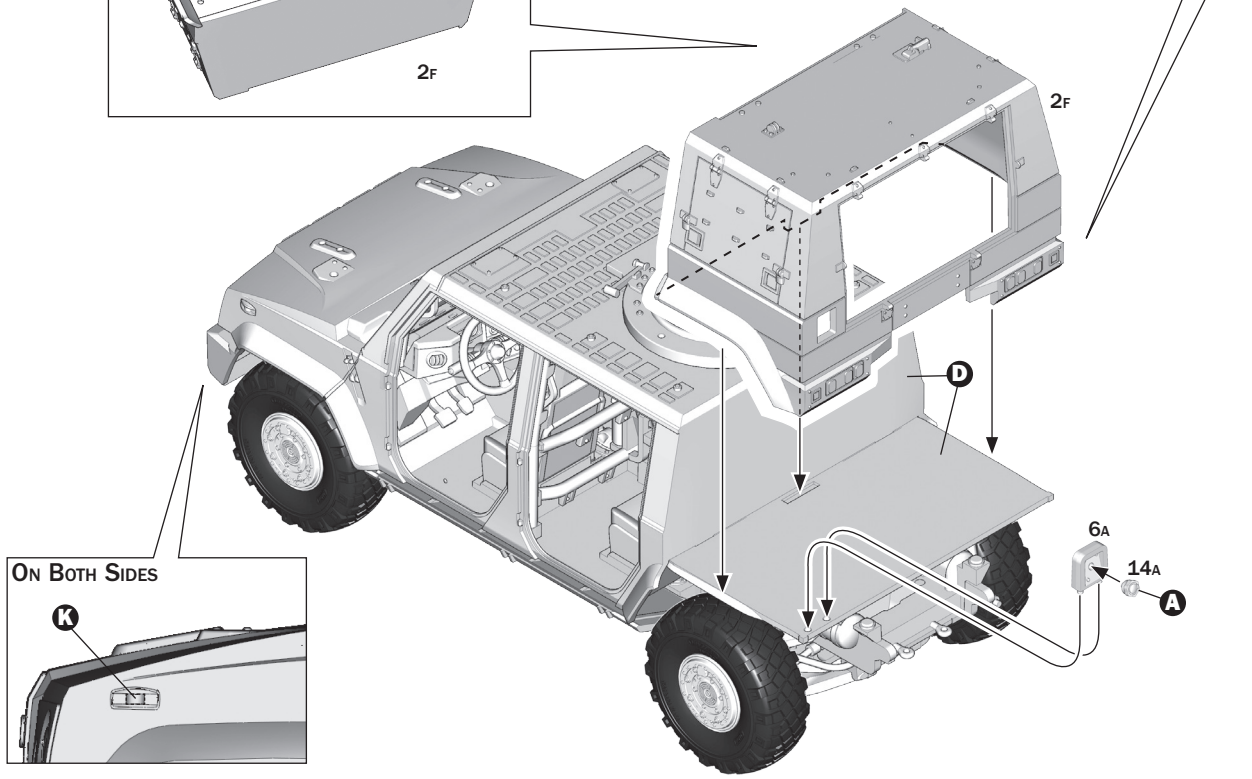
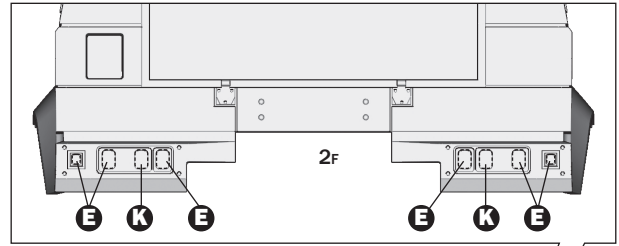
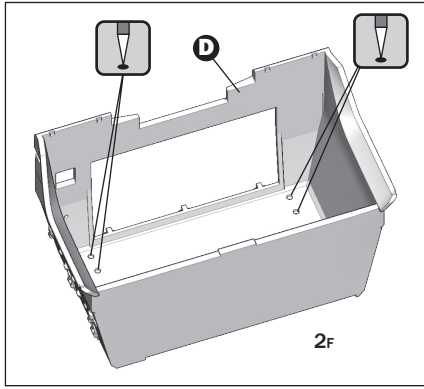

22

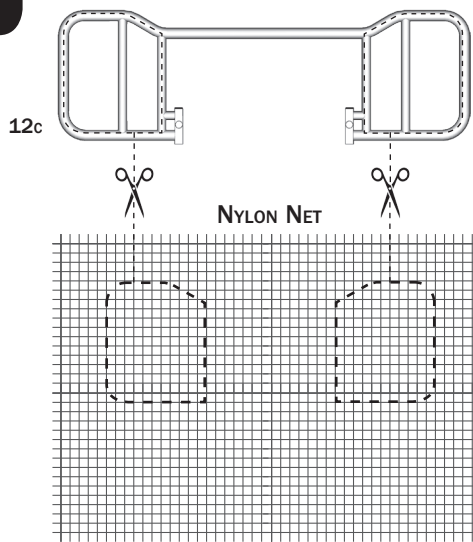

N

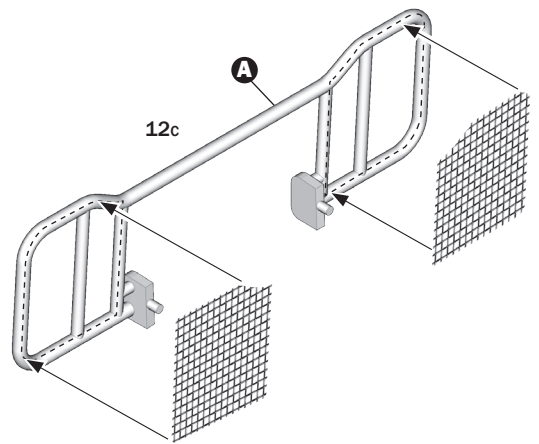

23

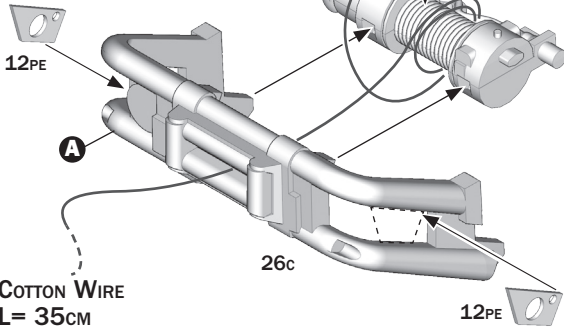
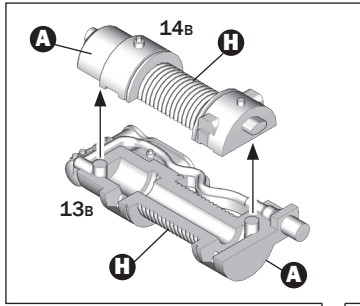

0

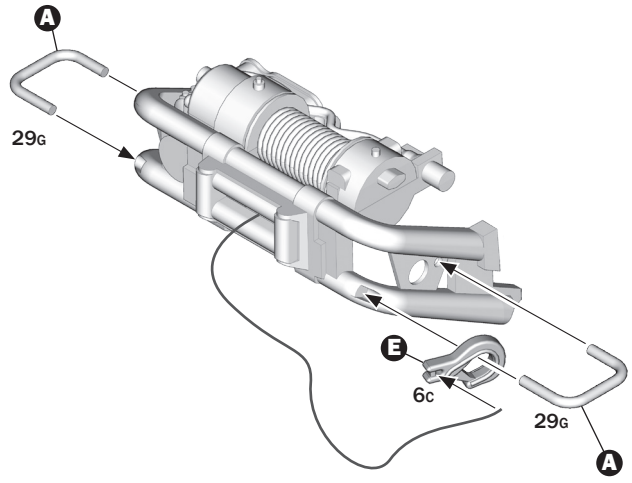

24

VERSION A-B-D

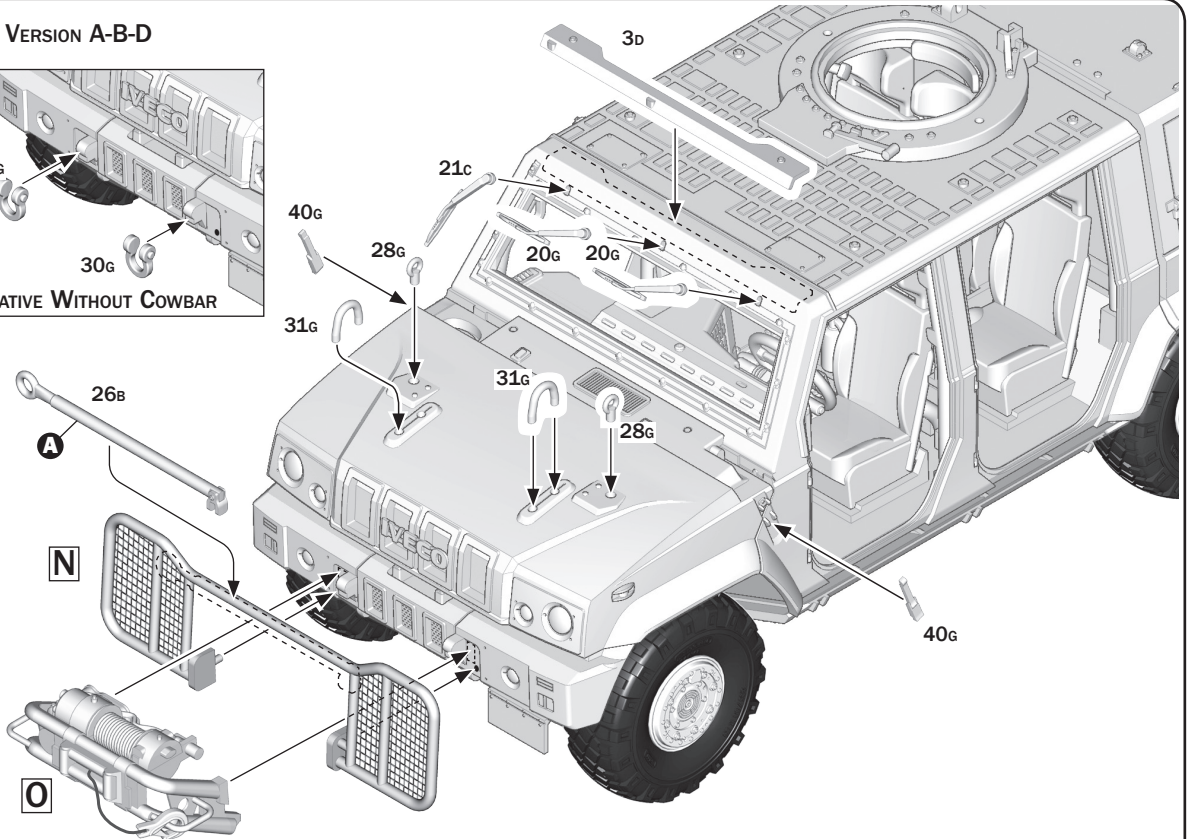
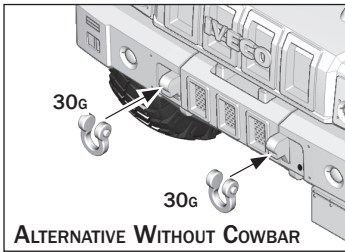

25

VERSION C

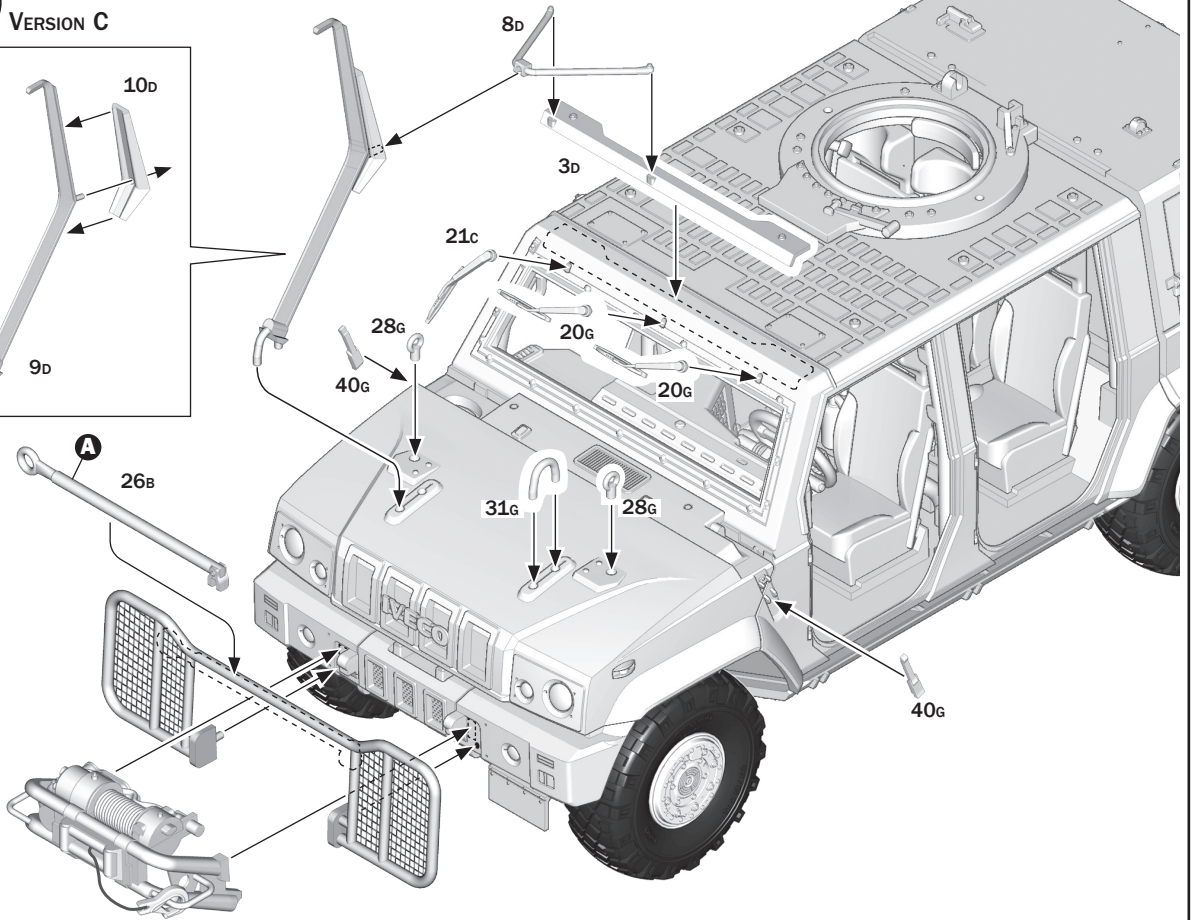
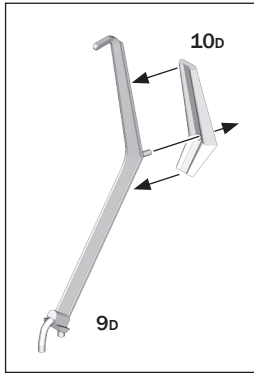

26

P

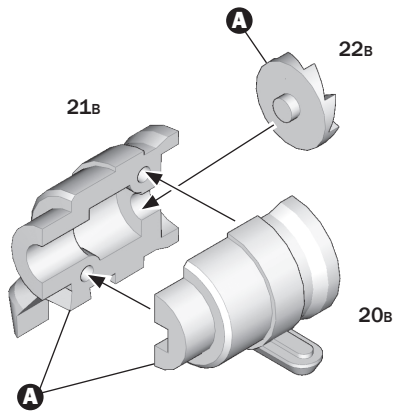

Q

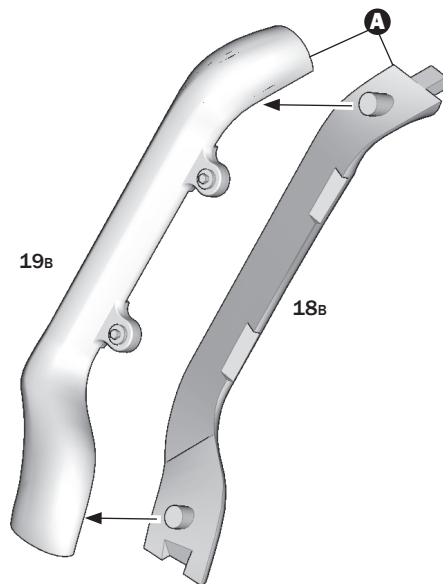

27

POSITIONING

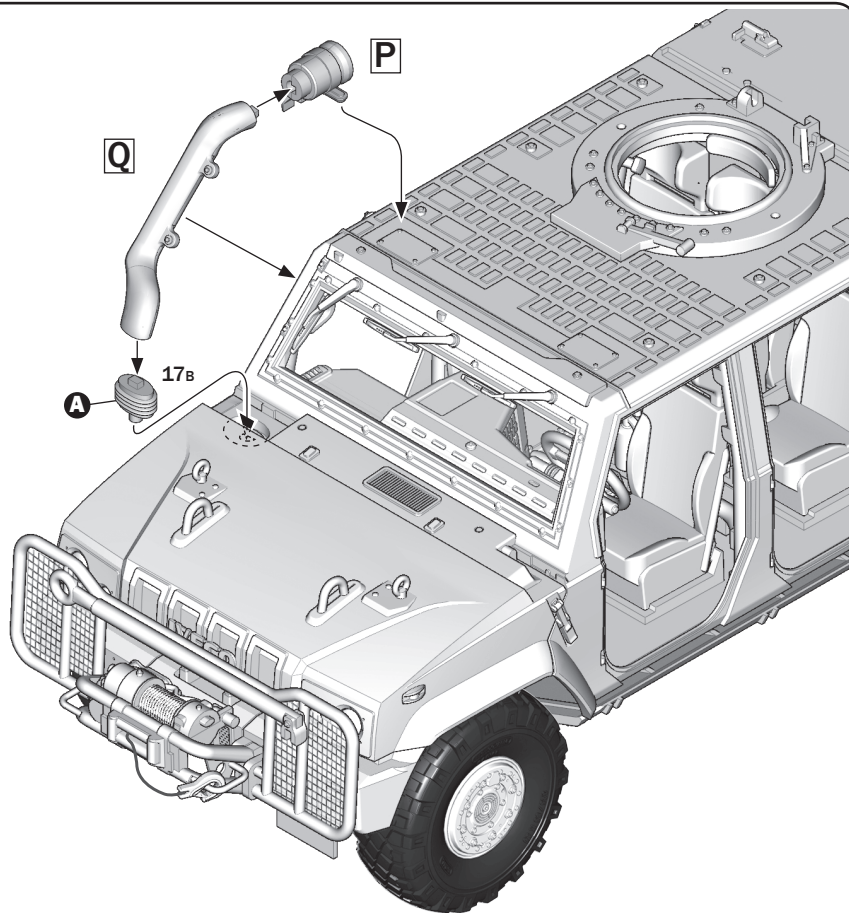
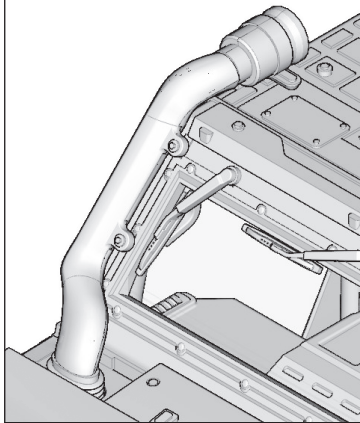

28

R

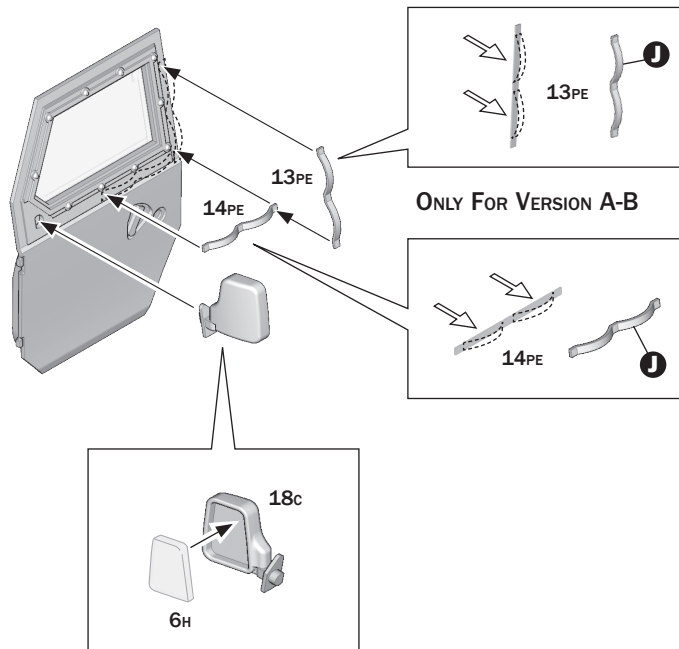
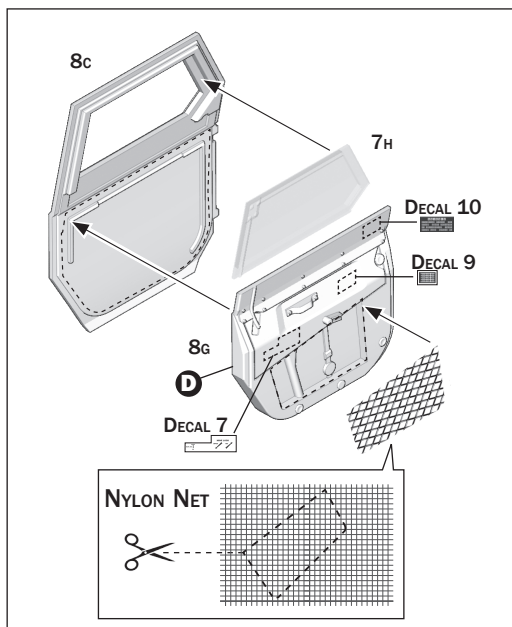

29

S

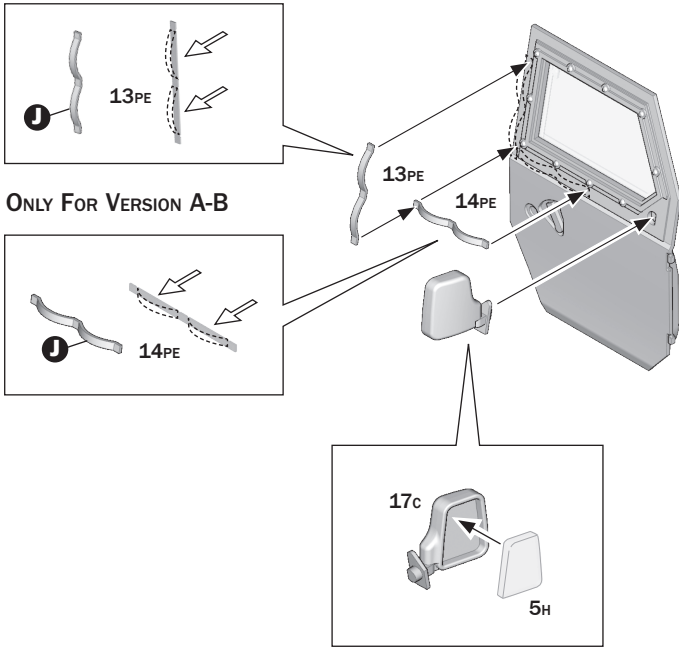

ONLY FOR VERSION A-B

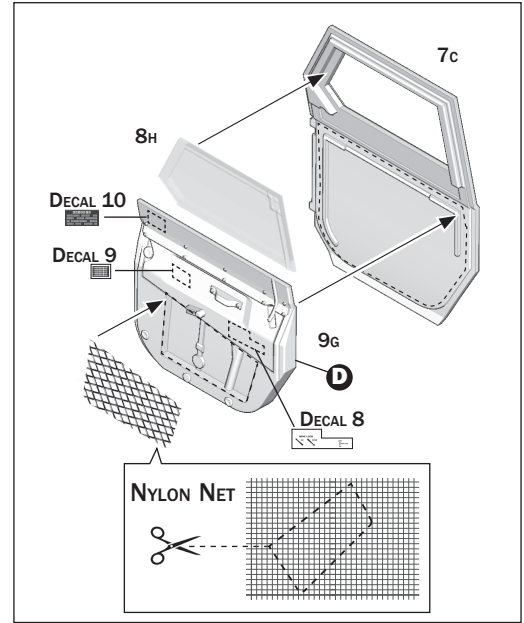

30

T

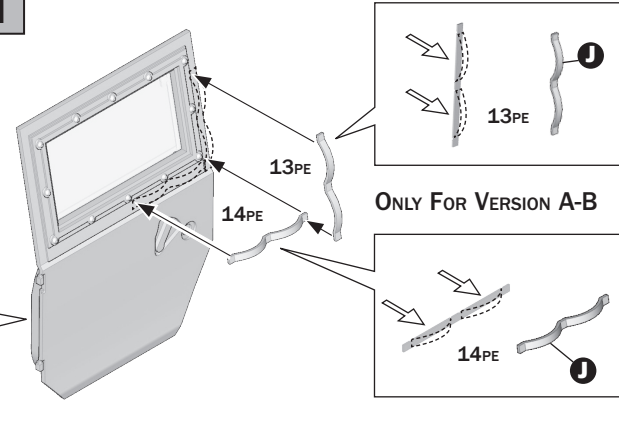
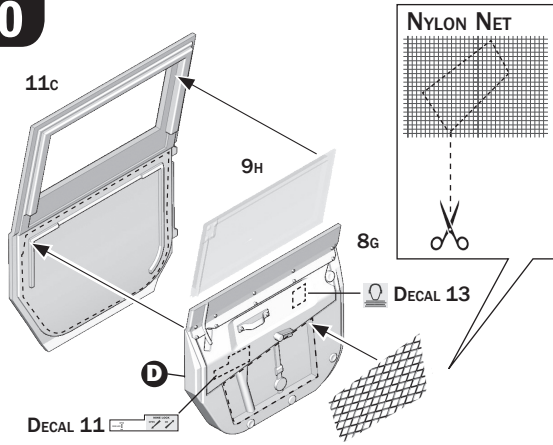

ONLY FOR VERSION A-B

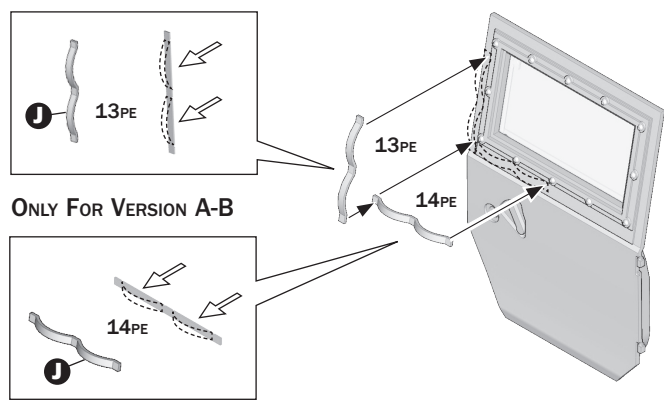

ONLY FOR VERSION A-B

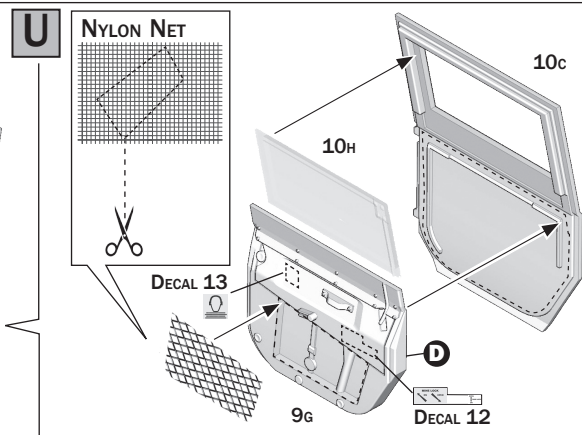



31

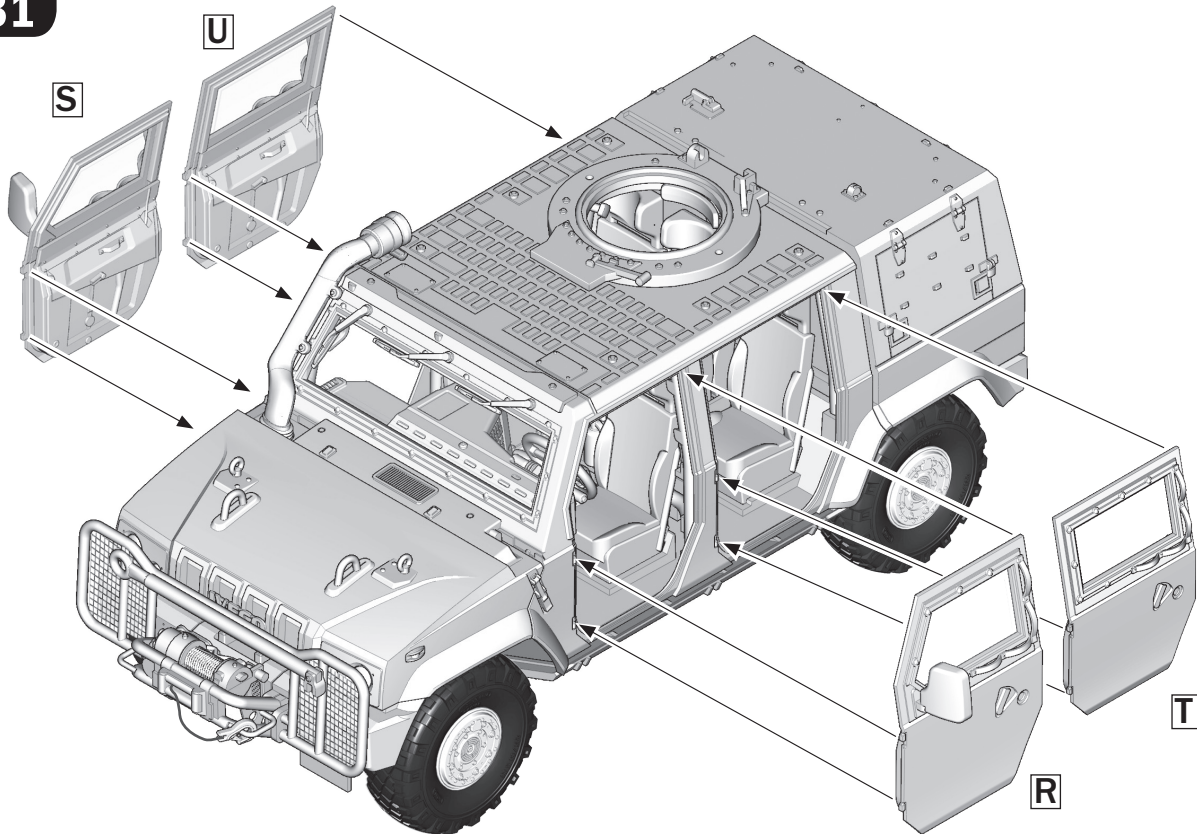

32

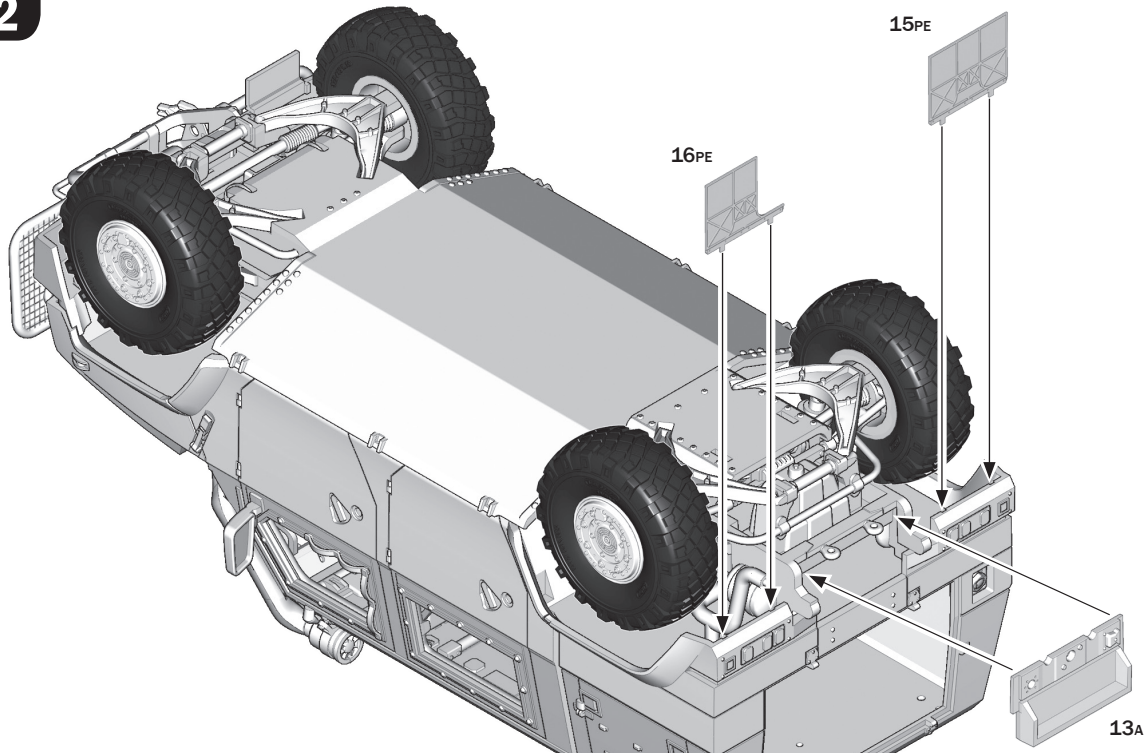

33

V

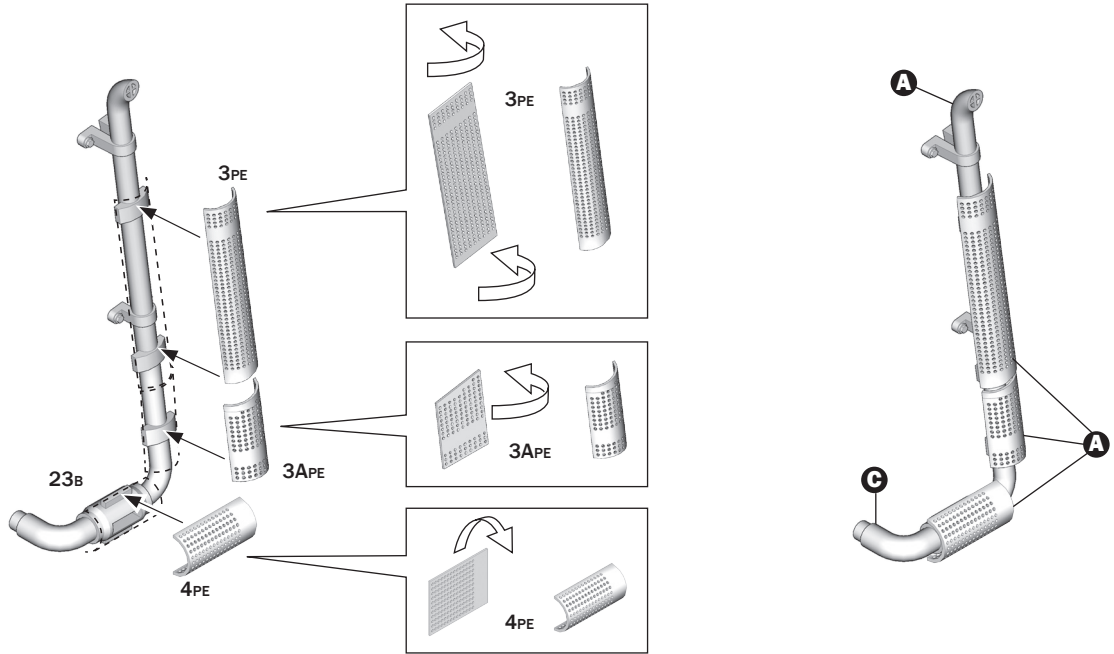

34

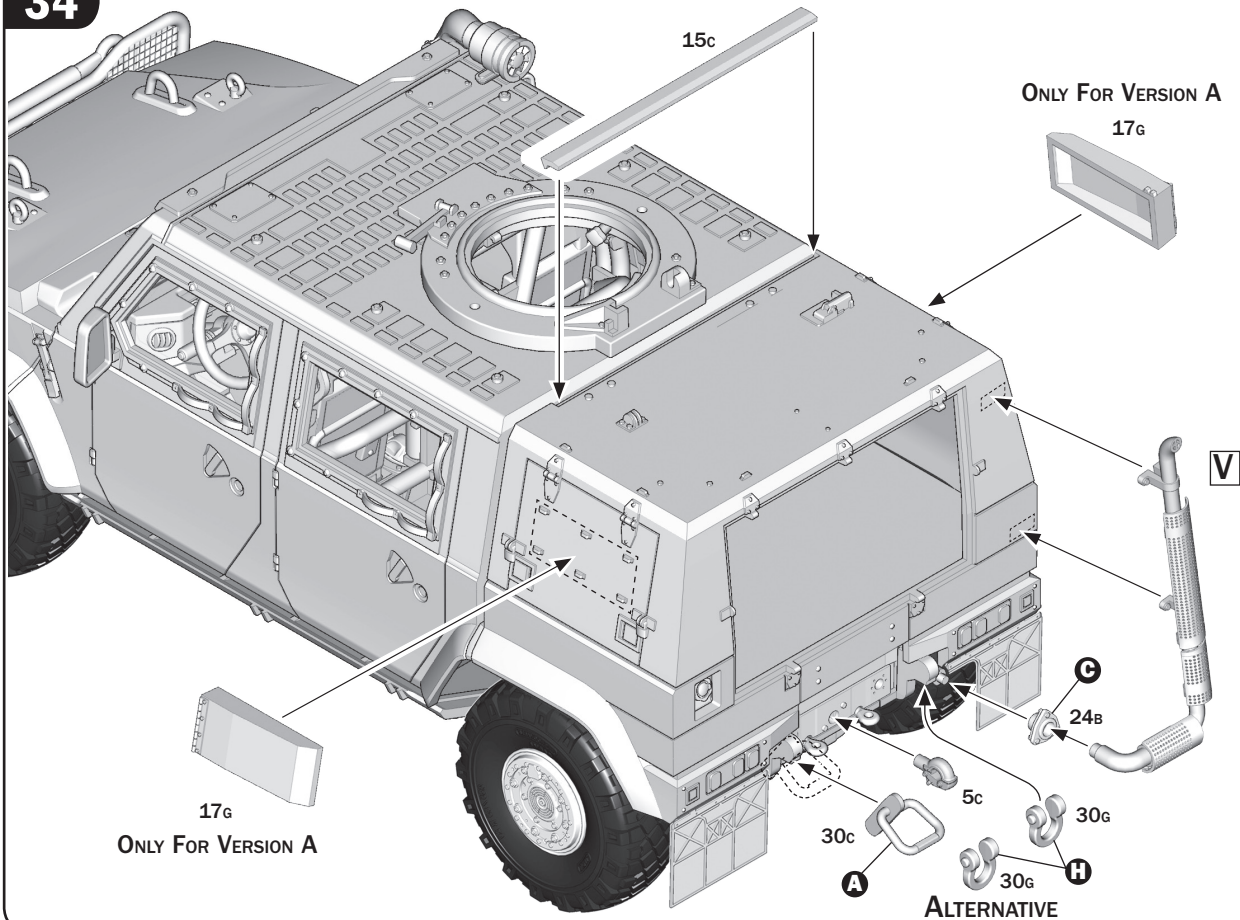

35

VERSION A

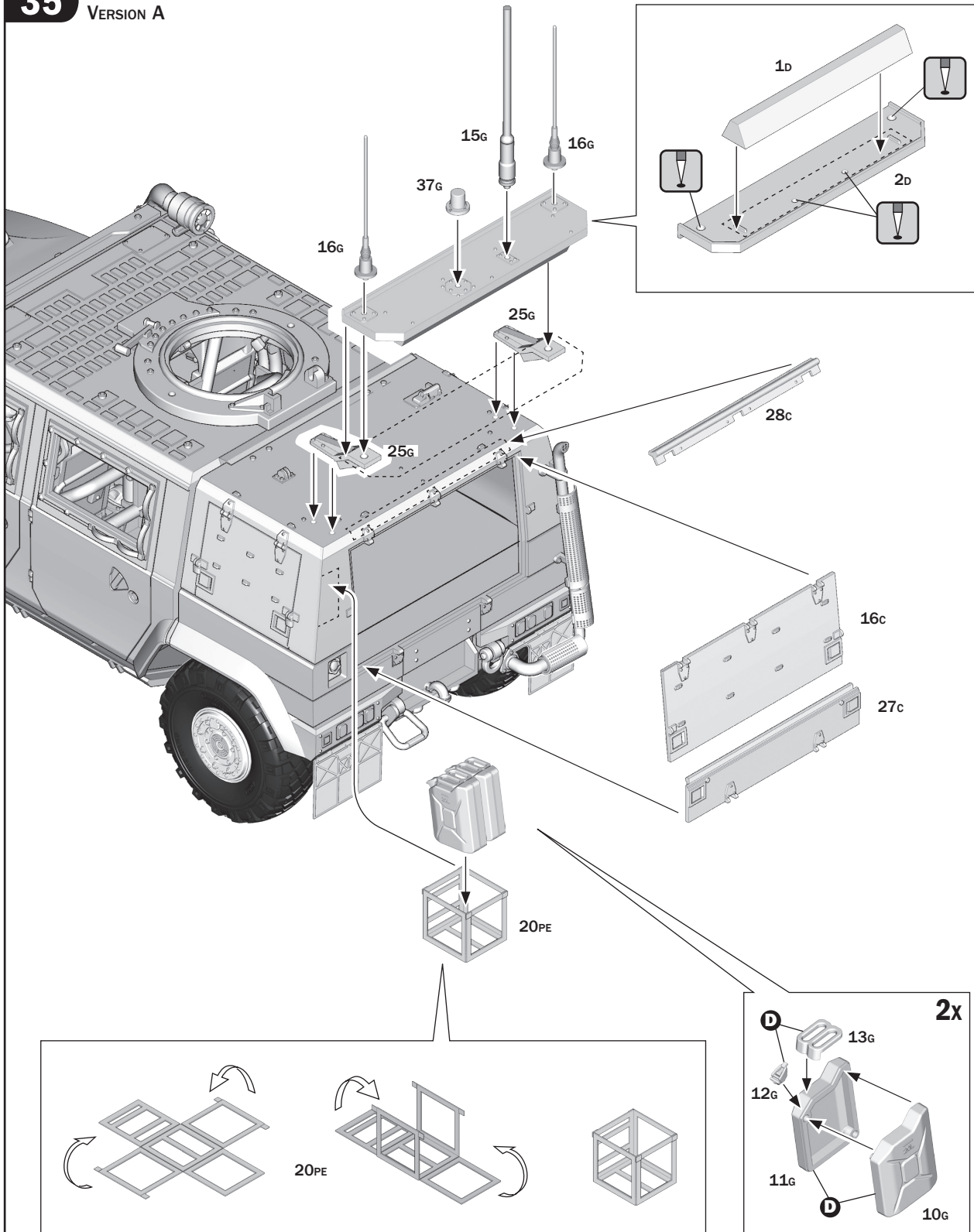

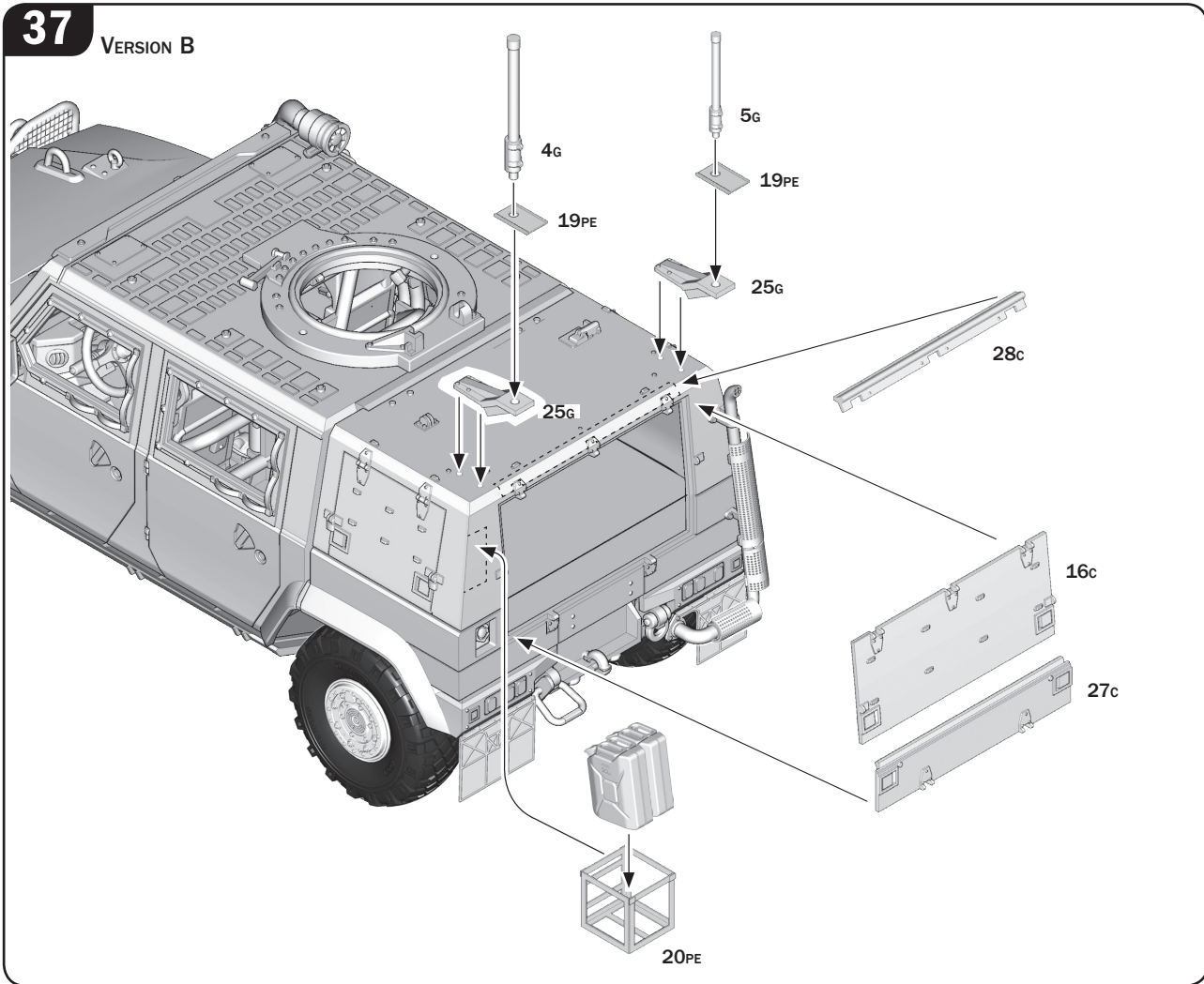
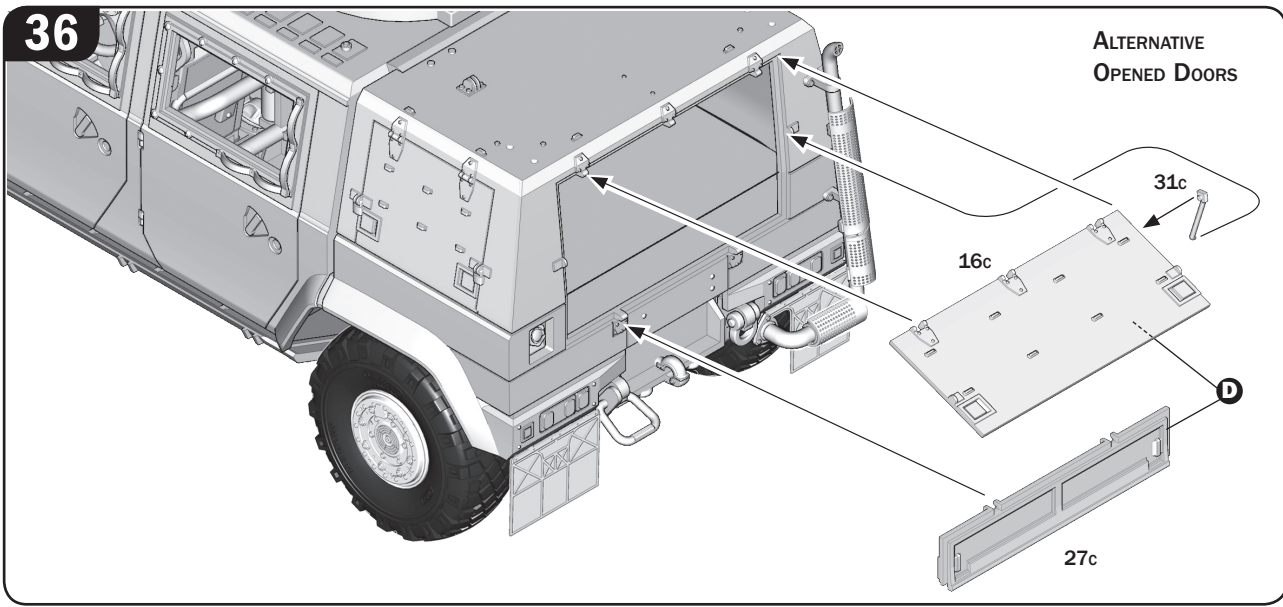



38

Y

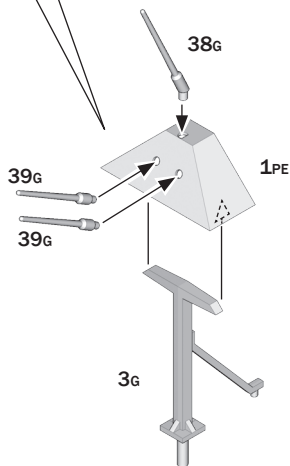
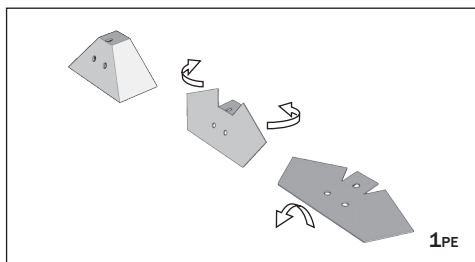

Z

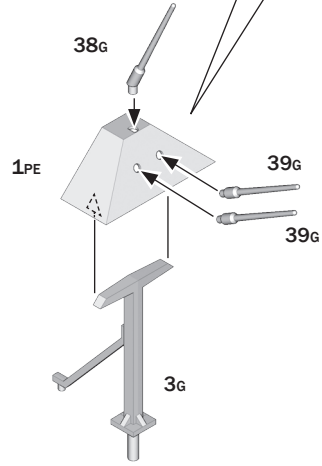
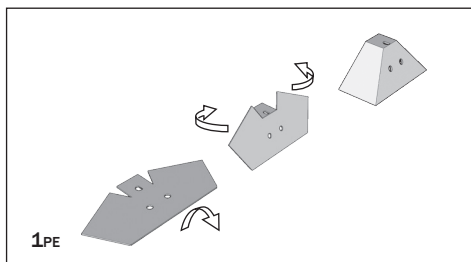

39

J

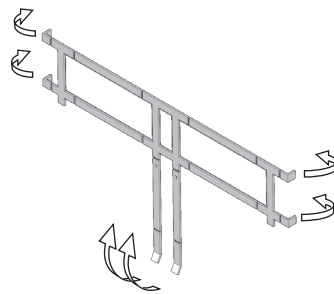
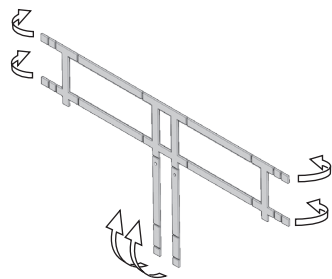

17PE

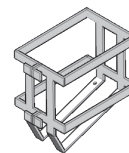
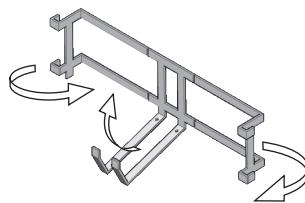
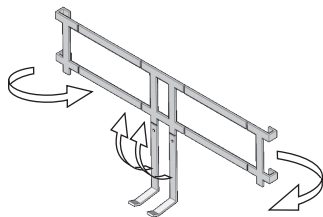

40

VERSION C

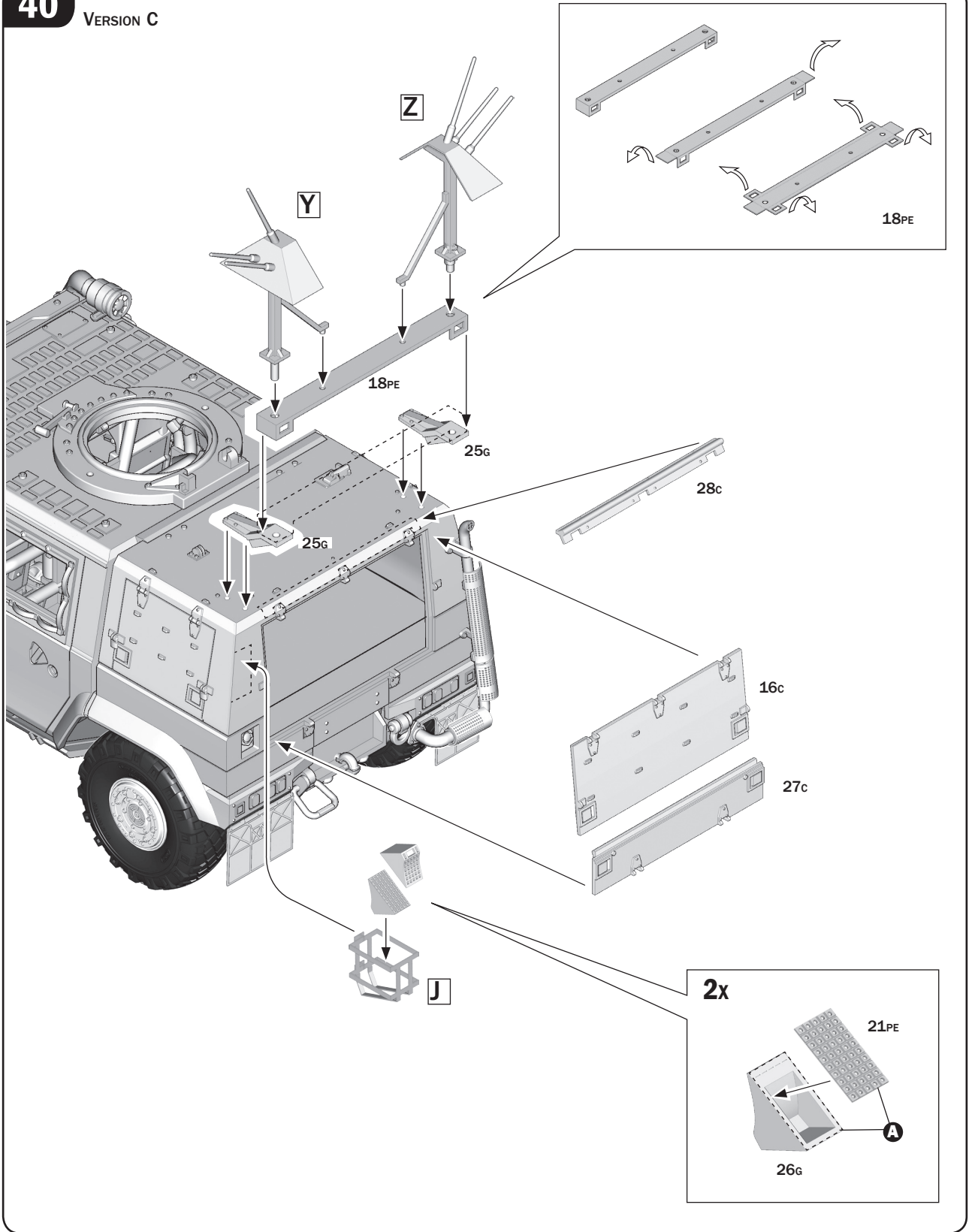

41

K

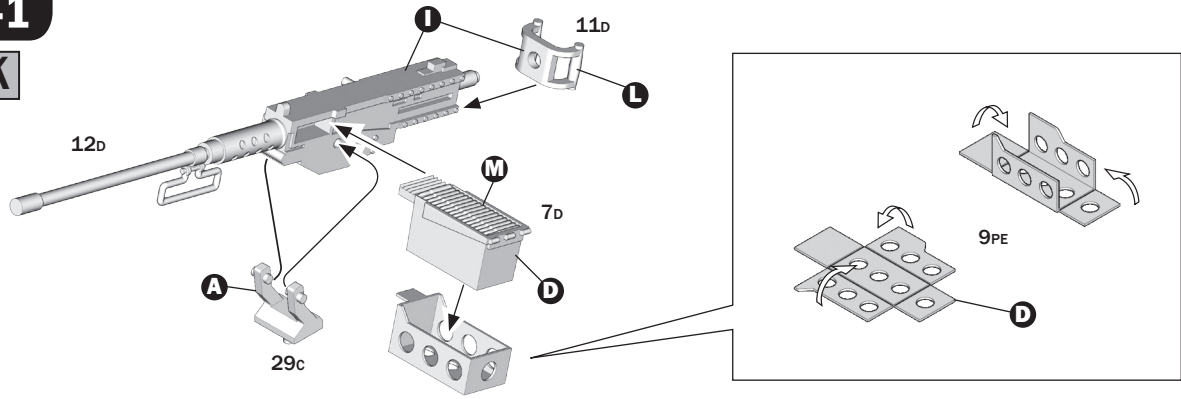

X

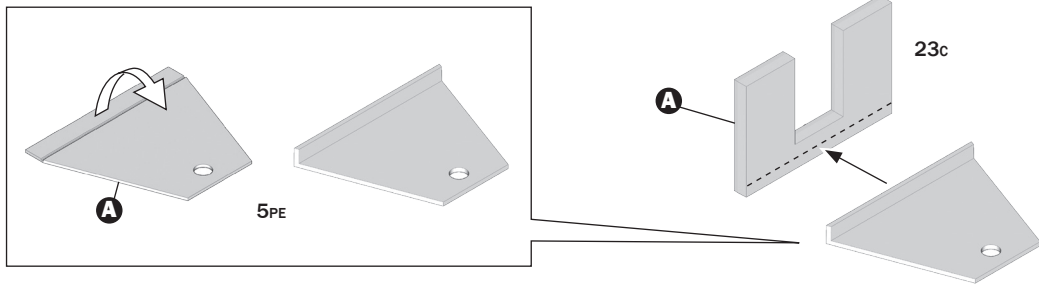

W

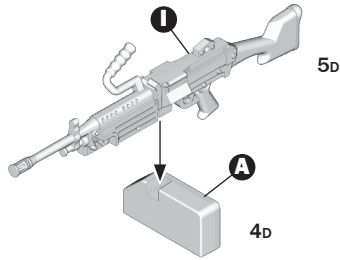

42

A1

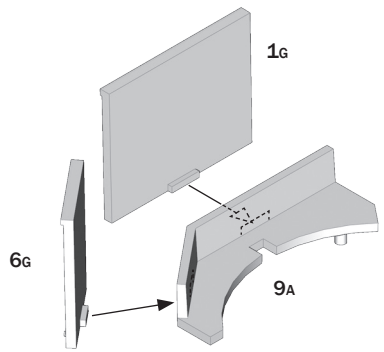

B1

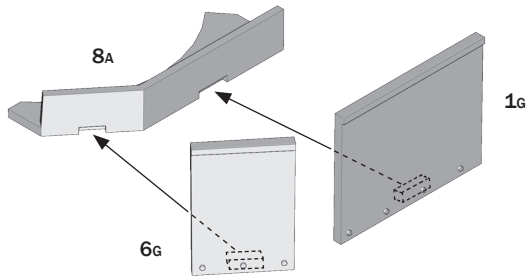

43

W VERSION A

VERSION A-B

K

X

24c

2c

D

18g

18g

6d

19g

19g

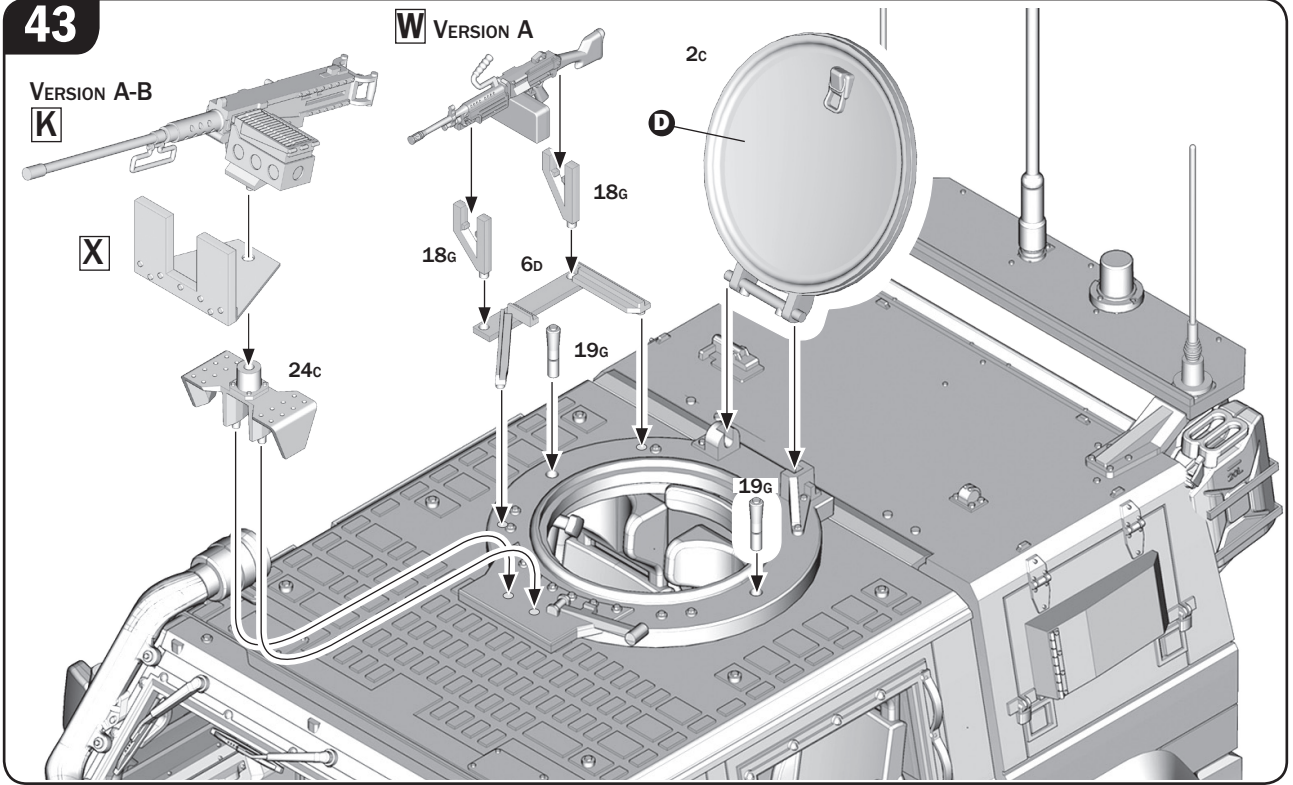

44

VERSION C

K

X

24c

2c

D

A1

19g

19g

B1

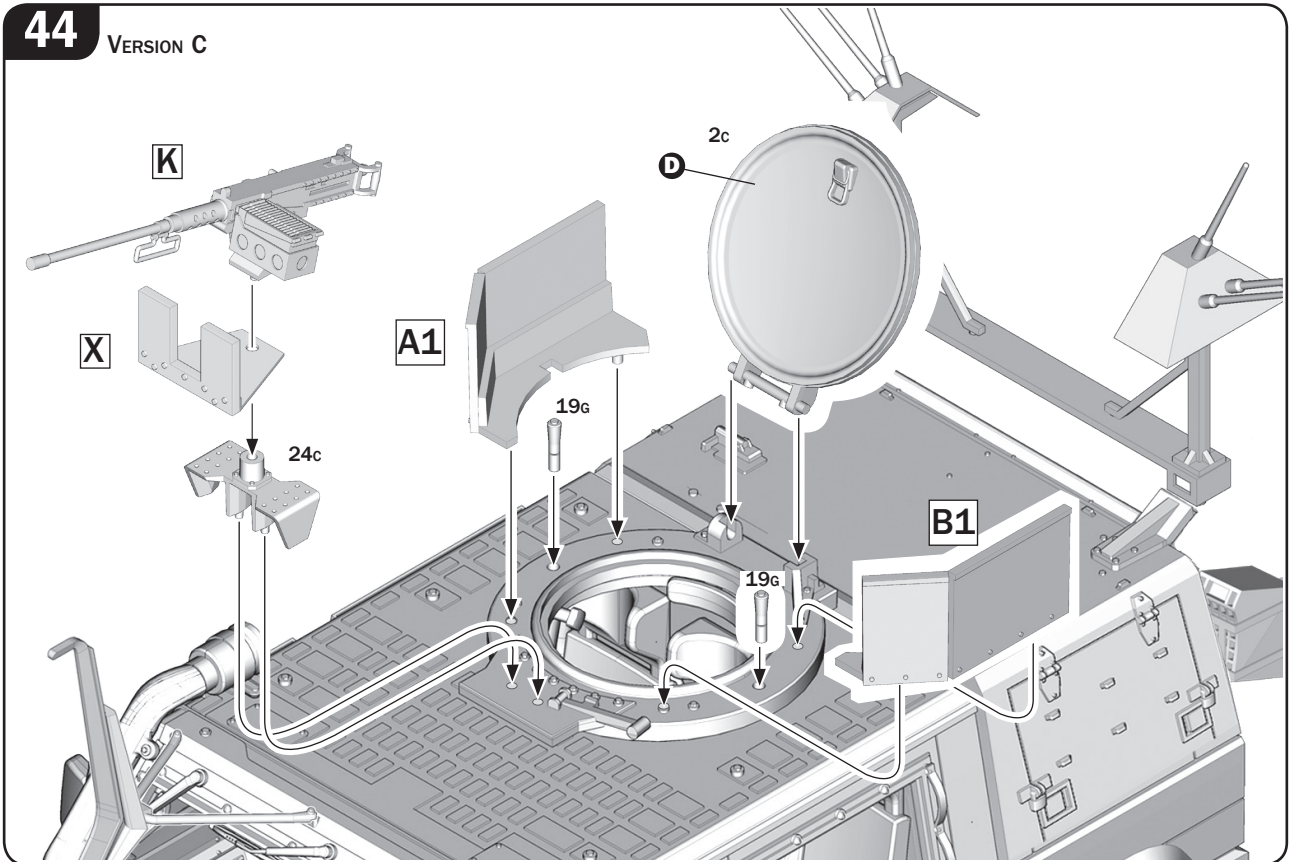

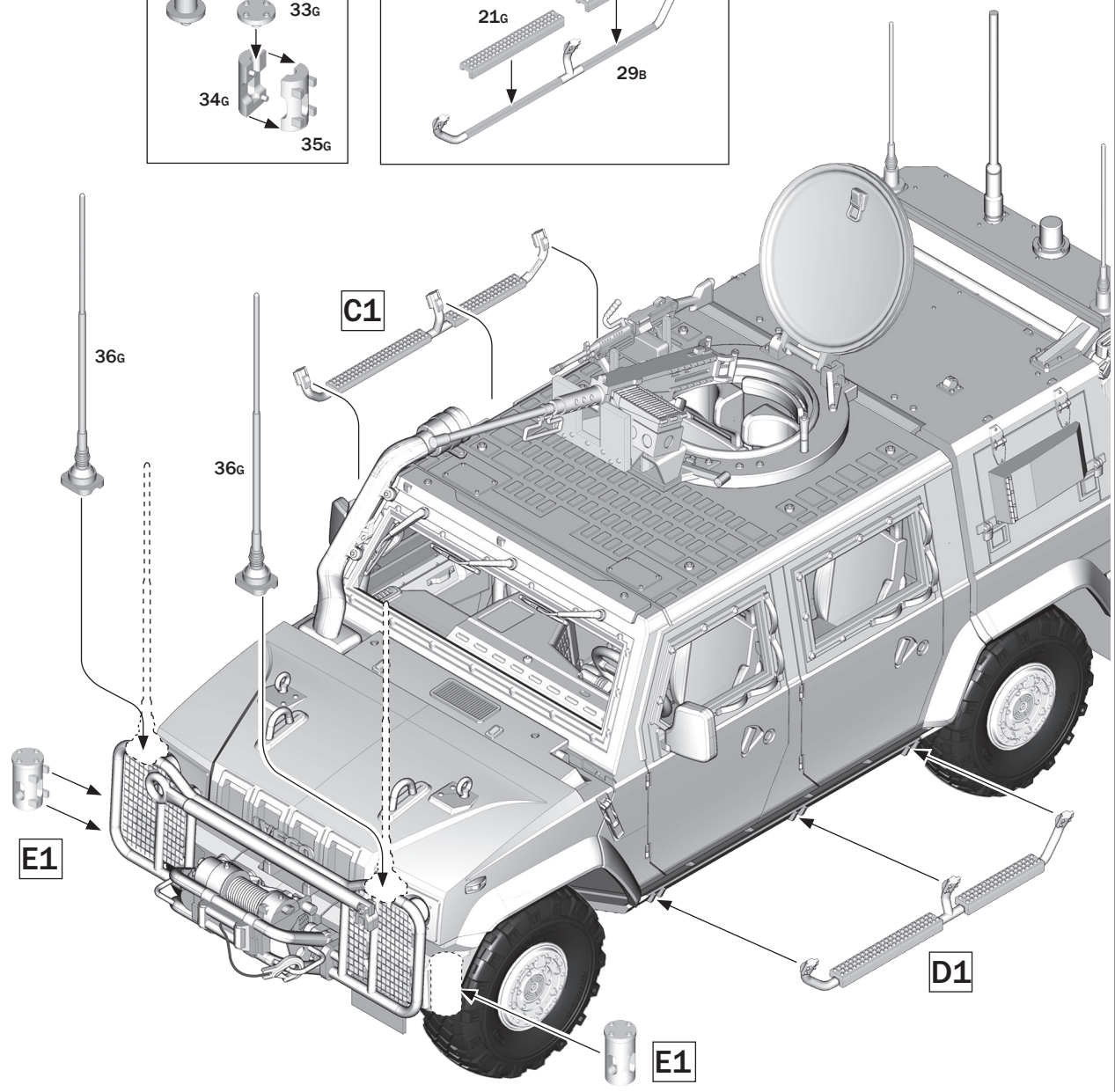
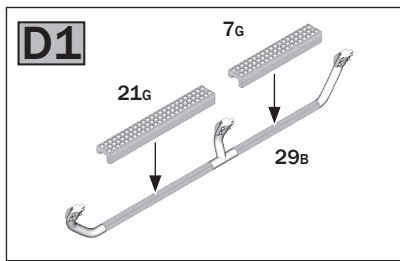
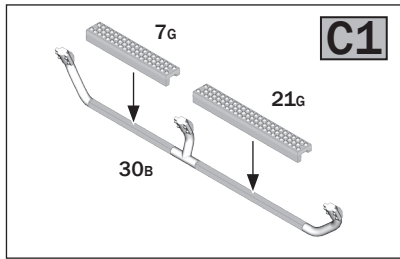
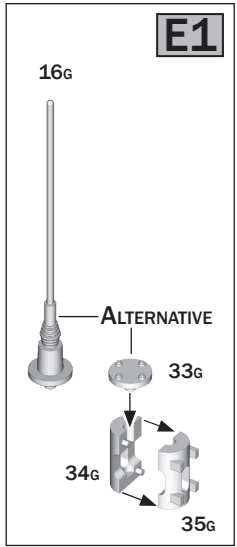



A. Esercito Italiano, ISAF, Afghanistan, 2010.

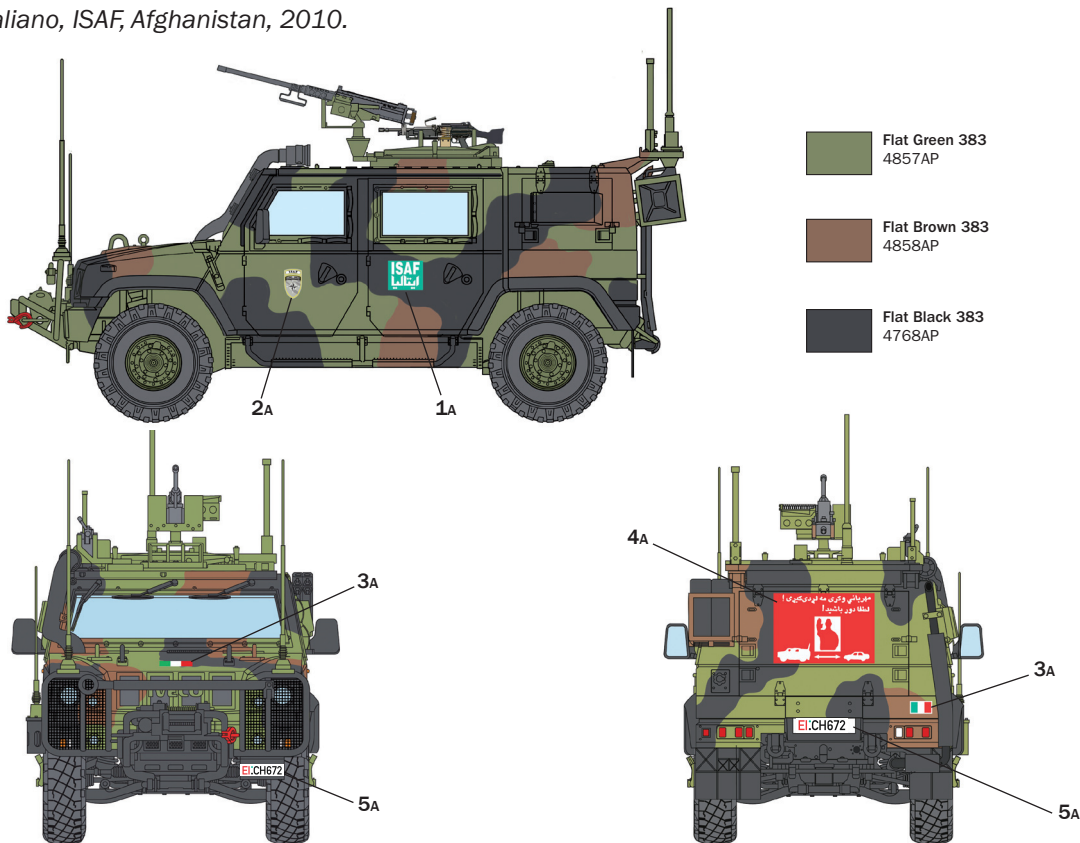

B. Task Force 45, Raggruppamento subacquei e incursori "Teseo Tesei", Operation Sarissa, Afghanistan, 2006.

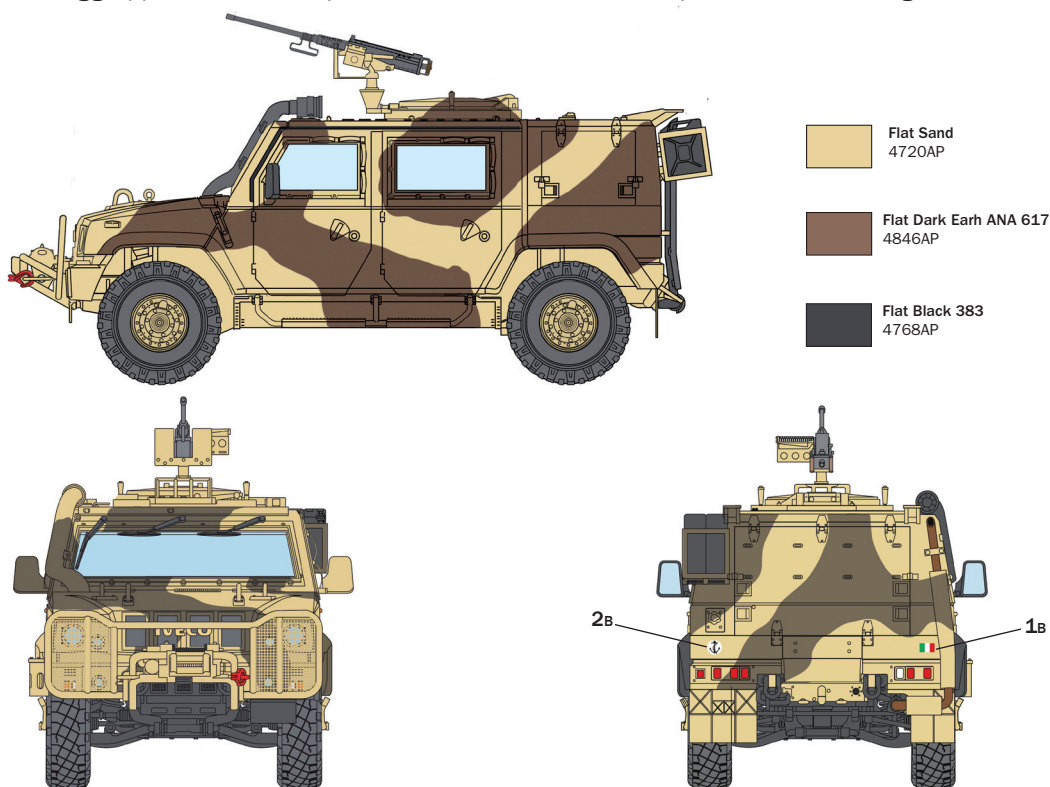



C. Spanish Army, Guardia Civil, ISAF, Afghanistan, 2009.

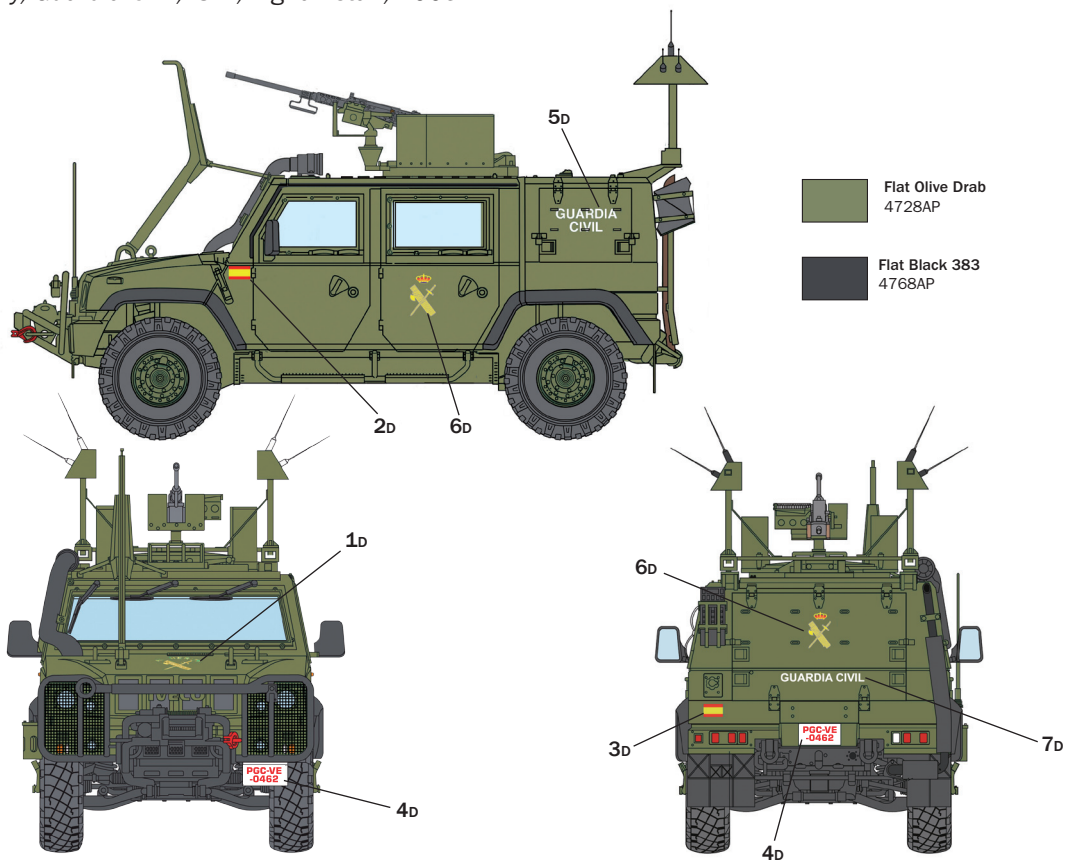

D. Croatian Army, BSD, EUFOR, Tchad, 2009.

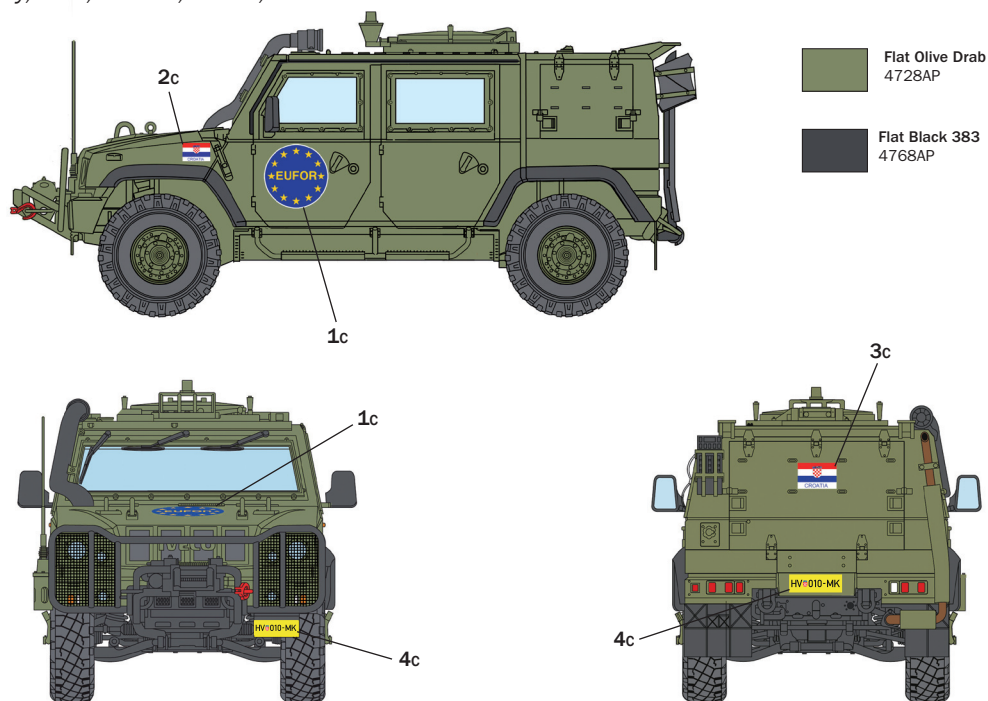

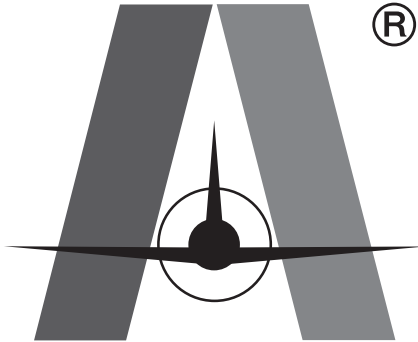

®

ITALERI



KIT No 6504 Scale 1:35 - LMV Lince

NAME NOME NAME NOM NOMBRE NAAM	POSTAL CODE C.A.P. POSTALEITZAH CODE POSTALE CODIGO POSTAL POSTCODE	COUNTRY NAZIONE LAND PAIS PAIS LAND	DATE OF BIRTH DATA DI NASCITA GEBURTSDATUM DATE DE NAISSANCE NACIDO/ A EL GEBORTE DATUM
_____	_____	_____	_____

ADDRESS
INDIRIZZO
ADRESSE
DIRECCION
ADRES

TOWN
CITTA'
STADT
VILLE
CIUDAD
GEMEENTE

E-MAIL

DEFECTIVE PARTS
PARTI DIFETTOSE
DEFEKTE TEILE
PIECES DEFECTUEUSES
PIEZAS DEFECTUOSAS
DEFECTE ONDERDELEN

PLACE OF PURCHASE
ACQUISTATO PRESSO
ORT DES KAUFES
LIEU D'ACHAT
LUGAR DE COMPRA
PLAATS VAN AANKOOP

<input type="checkbox"/> Retail Store Negozio Einzelhandel Detailliant Detailista Detailhandel	<input type="checkbox"/> Hyper Market Grande Magazzino Andero Grande Surface Gran Almacen Hypermarket
---	--

ITALERI S.p.A.
Via Pradazzo, 6/B
40012 - Calderara di Reno (BO) ITALY
fax: 0039 51 726 459
e-mail: italeri@italeri.com
www.italeri.com

842006504

