

Made in Italy

**1:24** scale**No 3961**

# Scania S770 4x2 Normal Roof

**EN**

Scania S series – a key player in the industrial and heavy commercial vehicles market – has been designed to meet long-range logistics and transportation needs. The new S series was introduced by the famous Scandinavian manufacturer to the market in 2016, and included new innovative design solutions. Key design features were incorporated to optimize the use of the space inside the cabin to enhance driver comfort, and greater attention was afforded to more modern 'active and passive' safety systems to aid driver control and overall vehicle management. The attractive and contemporary new design also reflected the modern aerodynamics of the vehicle and its reduced fuel consumption targets. The Scania S770 4x2 "Normal Roof" with compact cab and the "Highline" version with the oversized cab, are the industry 'road tractors' produced by the famous Scandinavian manufacturer of heavy commercial vehicles, with both versions offering excellent options for differing professional and operational requirements.

**IT**

La serie S di Scania costituisce un punto di riferimento sul mercato dei veicoli commerciali ed industriali pesanti destinati a soddisfare i bisogni della logistica e dei trasporti di lungo raggio. La nuova serie S venne introdotta dal celebre produttore Scandinavo sul mercato nella seconda metà dell'ultimo decennio adottando soluzioni progettuali innovative. Il nuovo progetto venne infatti realizzato per ottimizzare l'impiego degli spazi interni alla cabina ed esaltare il comfort del conducente. Grande attenzione alla sicurezza attiva e passiva attraverso l'adozione dei più moderni sistemi di controllo e di assistenza alla guida. Il nuovo design, accattivante e moderno, è stato realizzato anche per tenere in considerazione l'aerodinamica del veicolo e la riduzione del consumo di carburante. Lo Scania S770 4x2 "Normal Roof" con la cabina compatta è la soluzione ideale per numerose necessità professionali ed operative ed affianca la versione "Highline" con cabina maggiorata della motrice stradale del celebre produttore scandinavo di veicoli industriali e commerciali pesanti.

**DE**

Die S-Serie von Scania ist ein Maßstab auf dem Markt für schwere Nutz- und Industriefahrzeuge, die für die Anforderungen von Logistik und Fernverkehr konzipiert sind. Die neue S-Serie wurde von dem berühmten skandinavischen Hersteller in der zweiten Hälfte des letzten Jahrzehnts mit innovativen Designlösungen auf den Markt gebracht. Tatsächlich wurde das neue Design entwickelt, um die Raumnutzung im Fahrerhaus zu optimieren und den Fahrerkomfort zu erhöhen. Durch modernste Steuerungs- und Fahrerassistenzsysteme wird der aktiven und passiven Sicherheit große Bedeutung beigemessen. Außerdem wurde das neue, attraktive und moderne Design auch im Hinblick auf die Aerodynamik des Fahrzeugs und die Reduzierung des Kraftstoffverbrauchs entwickelt. Der Scania S770 4x2 'Normal Roof' mit seiner kompakten Fahrerkabine ist die ideale Lösung für viele professionelle und betriebliche Anforderungen und ergänzt die 'Highline'-Version mit verlängerter Fahrerkabine der Sattelzugmaschine des renommierten skandinavischen Herstellers von schweren Nutz- und Industriefahrzeugen.

**FR**

La série S de Scania constitue une référence sur le marché des véhicules commerciaux et industriels lourds destinés à satisfaire les besoins de la logistique et des transports long distance. La nouvelle série S fut mise sur le marché par le célèbre producteur scandinave lors de la seconde moitié de la décennie passée, en adoptant des solutions de conception innovantes. En effet, le nouveau projet fut réalisé pour optimiser l'utilisation des espaces intérieurs de la cabine et améliorer le confort du conducteur. Une grande attention fut accordée à la sécurité active et passive, à travers l'adoption des systèmes les plus modernes de contrôle et d'aide à la conduite. Le nouveau design, séduisant et moderne, a aussi été réalisé en tenant compte de l'aérodynamisme du véhicule et de la réduction de la consommation de carburant. Le Scania S770 4x2 « Normal Roof » avec sa cabine compacte est la solution idéale pour de nombreux besoins professionnels et opérationnels et complète la version « Highline » avec cabine allongée du tracteur routier du célèbre constructeur scandinave de véhicules industriels et commerciaux lourds.

**ES**

La serie S de Scania es un referente en el mercado de los vehículos comerciales e industriales pesados diseñados para satisfacer las exigencias de la logística y el transporte de larga distancia. La nueva serie S fue introducida en el mercado por el famoso fabricante escandinavo en la segunda mitad de la última década mediante la adopción de soluciones de diseño innovadoras. De hecho, el nuevo diseño fue creado para optimizar el uso de los espacios internos de la cabina y mejorar la comodidad del conductor. Y una gran atención a la seguridad activa y pasiva mediante la adopción de los más modernos sistemas de control y asistencia a la conducción. El nuevo diseño, atractivo y moderno, se realizó también teniendo en cuenta la aerodinámica del vehículo y la reducción del consumo de combustible. El Scania S770 4x2 "Normal Roof", con su cabina compacta, es la solución ideal para muchas necesidades profesionales y operativas, y complementa la versión 'Highline' con cabina ampliada del vehículo de carretera del famoso fabricante escandinavo de vehículos comerciales e industriales pesados.

**RU**

Серия S компании Scania является эталоном на рынке тяжелых коммерческих и промышленных автомобилей, разработанных для удовлетворения потребностей логистики и магистральных перевозок. Известный скандинавский производитель ввел на рынок новую серию S во второй половине прошлого десятилетия, взяв за основу ультрасовременные дизайнерские решения. Новый дизайн был разработан для оптимизации использования пространства внутри кабины и для повышения комфорта водителя. Большое внимание уделяется активной и пассивной безопасности благодаря внедрению самых современных систем управления и помощи водителю. Новый дизайн, привлекательный и современный, был также выполнен с учетом аэродинамики автомобиля и снижения расхода топлива. Scania S770 4x2 "Normal Roof" с компактной кабиной является идеальным решением для многих профессиональных и производственных нужд и дополняет версию "Highline" с увеличенной кабиной дорожного тягача от известного скандинавского производителя тяжелых коммерческих и промышленных автомобилей.

**EN WARNING:** Model for adult collector age 14 and over**IT ATTENZIONE:** Modello per collezionisti adulti di età superiore ai 14 anni**FR ATTENTION:** Modèle pour modélistes de 14 ans et plus.**DE ACHTUNG:** Modellbausätze Für Modellbauer über 14 Jahre.**NL WAARSCHWING:** Geschikt voor 14 jaar en ouder.**ES ATENCION:** Modelo para modelistas mayores de 14 años.

**EN ATTENTION - Useful advice!**

Study the instructions carefully prior to assembly. Remove parts from frame with a sharp knife or a pair of scissor and trim away excess plastic. Do not pull of parts. Assemble the parts in numerical sequence. Use plastic cement ONLY and use cement sparingly to avoid damaging the model. Black arrows indicate parts to be glued together. White arrows indicate on which frame the parts must be assembled WITHOUT using cement. These letters (A - B - C...) indicate on which frame the parts will be found. Paint small parts before detaching them from frame. Remove paint where parts are to be cemented. Crossed out parts must not be used.

**IT ATTENZIONE - Consigli utili!**

Prima di iniziare il montaggio studiare attentamente il disegno. Staccare con molta cura i pezzi dalle stampate, usando un taglia-balsa oppure un paio di forbici e togliere con una piccola lima o con carta vetro fine eventuali sbavature. Mai staccare i pezzi con le mani. Montarli seguendo l'ordine delle numerazione delle tavole. Eliminare dalla stampata il numero del pezzo appena montato facendogli sopra una croce. Le frecce nere indicano i pezzi da incollare, le frecce bianche indicano i pezzi da montare senza colla. Usare solo colla per polistirolo. Le lettere (A - B - C...) ai lati dei numeri indicano la stampata ove si trova il pezzo da montare. I pezzi sbarrati da una croce non sono da utilizzare.

**DE ACHTUNG - Ein nützlicher Rat!**

Vor der Montage die Zeichnung aufmerksam studieren. Die einzelnen Montageteile mit einem Messer oder einer Schere vom Spritzling sorgfältig entfernen. Eventuelle Grate werden mit einer Klinge oder feinem Schmirgelpapier beseitigt. Keinesfalls die Montageteile mit den Händen entfernen. Bei der Montage der Tafelnummerierung folgen. Pfeile zeigen die zu klebenden Teile während die weissen Pfeile die ohne Leim zu montierenden Teile anzeigen. Bitte nur Plastikklebstoff verwenden. Die Buchstaben (A - B - C...) neben den Nummern zeigt, auf welchem Spritzling der zu montierende Teil zu finden ist. Die mit einem Kreuz markierten Teile sind nicht zu verwenden.

**FR ATTENTION - Conseils utiles!**

Avant de commencer le montage, étudier attentivement le dessin. Détacher avec beaucoup de soin les morceaux des moules en usant un massicot ou bien un pair de ciseaux et couper avec une petite lame avec de papier de verre fin ébarbagés éventuels. Jamais détacher les morceaux avec le mains Monter les en suivant l'ordre de la numération des tables. Eliminer de la moule le numéro de la pièce qui vient d'être montée, en le bifant avec une croix. Les flèches noires indiquent les pièces à coller, les flèches blanches indiquent les pièces à monter sans colle. Employer seulement de la colle pour polystiroil. Les lettres (A - B - C...) aux côtés des numéros indiquent la moule où se trouve la pièces à monter. Les pièces marquées par une croix ne sont pas à utiliser.

**ES ATENCION - Consejos útiles!**

Estudiar las instrucciones cuidadosamente antes de comenzar el montaje. Separar las piezas de las bandejas con un cuchillo afilado o un par de tijeras y retirar el exceso de plástico o rebada. No arrancar las piezas. Montar las piezas en orden numérico. Utilizar SOLAMENTE pegamento para plástico y en poca cantidad para evitar que se dane el modelo. Las flechas negras indican las piezas que se deben pegar juntas. Las flechas blancas indican las piezas que deben ensamblarse SIN usar pegamento. Las letras (A - B - C...) indican en que bandeja se encuentran las piezas. Pintar las piezas pequeñas antes de separarlas de la bandeja. Retirar la pintura de los lugares por donde se deban pegar las piezas.

**RU ПРЕДУПРЕЖДЕНИЕ - чаевые!**

ПЕРЕД ТЕМ, КАК ПРИСТУПИТЬ К СБОРКЕ, ВНИМАТЕЛЬНО ИЗУЧИТЬ ЧЕРТЕЖ. ОЧЕНЬ ОСТОРОЖНО ОТСОЕДИНИТЬ РАСЧЕПАННЫЕ ЭЛЕМЕНТЫ, ИСПОЛЬЗОВАТЬ ДЛЯ ЭТОГО КАНЦЕЛЯРСКИЙ НОЖ ИЛИ ПАРУ НОЖИЦ, СНЯТЬ НЕРОВНОСТИ С ПОМОЩЬЮ ТОНКОГО ЛЕЗВИЯ ИЛИ С ПОМОЩЬЮ АБРАЗИВНОЙ БУМАГИ. НЕ ОТСОЕДИНЯТЬ ЭЛЕМЕНТЫ РУКАМИ. ВЫПОЛНИТЬ СБОРКУ СОГЛАСНО ПОРЯДКУ НУМЕРАЦИИ ТАБЛИЦ. УДАЛИТЬ ИЗ СПИСКА ТОЛЬКО ТО СБОРАННУЮ ДЕТАЛЬ, ПЕРЕЧЕРКИВАЯ ЕЕ. ЧЕРНЫЕ СТЕЛКИ УКАЗЫВАЮТ ДЕТАЛИ ДЛЯ СКЛЕИВАНИЯ, БЕЛЫЕ СТЕЛКИ УКАЗЫВАЮТ ДЕТАЛИ, КОТОРЫЕ СОБИРАЮТСЯ БЕЗ КЛЕЯ. ИСПОЛЬЗОВАТЬ ТОЛЬКО КЛЕЙ ДЛЯ ПЕНОПЛАСТА. БУКВЫ (А - В - С...) НА ПРОНУМЕРОВАННЫХ СТОРОНАХ УКАЗЫВАЮТ МЕСТ, ГДЕ НАХОДИТСЯ ДЕТАЛЬ. ПЕРЕЧЕРКНУТЫЕ ДЕТАЛИ НЕ ИСПОЛЬЗУЮТСЯ.

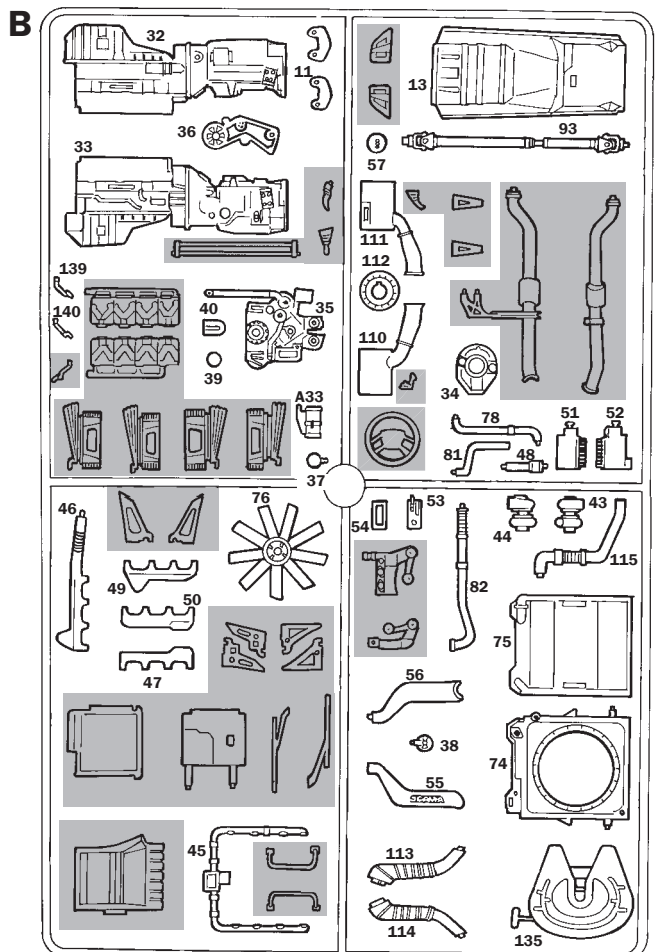
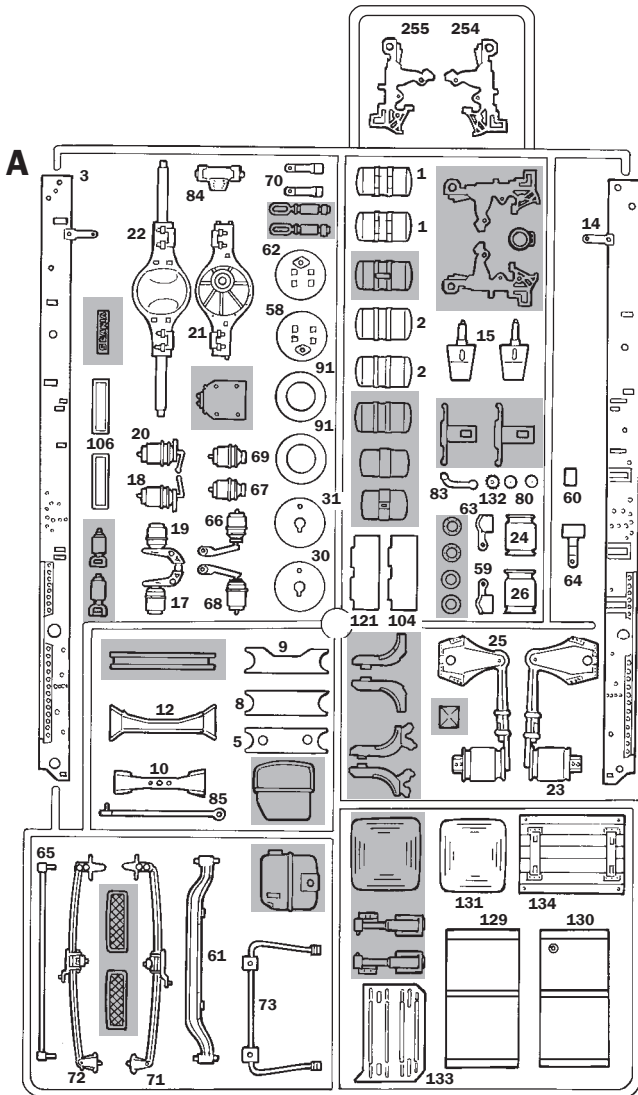
**SUGGESTED COLORS**

<b>A</b> METAL GLOSS SILVER F.S. 17178 ITALERI ACRYLCPAINT - 4678AP	<b>B</b> GLOSS WHITE F.S. 17875 ITALERI ACRYLCPAINT - 4696AP	<b>C</b> CLEAR RED F.S. 11302 TAMIYA X-27
<b>D</b> CLEAR ORANGE F.S. 12197 TAMIYA X-26	<b>E</b> FLAT DARK GRAY F.S. 36173 ITALERI ACRYLCPAINT - 4754AP	<b>G</b> FLAT INSIGNIA YELLOW F.S. 33538 ITALERI ACRYLCPAINT - 4721AP
<b>H</b> FLAT WHITE F.S. 35875 ITALERI ACRYLCPAINT - 4769AP	<b>L</b> GLOSS BLACK F.S. 17038 ITALERI ACRYLCPAINT - 4695AP	<b>N</b> FLAT MEDIUM BLUE F.S. 35095 ITALERI ACRYLCPAINT - 4307AP
<b>O</b> WASH GRAY ITALERI ACRYLCPAINT - 4955AP	<b>P</b> FLAT GULL GRAY F.S. 36622 ITALERI ACRYLCPAINT - 4763AP	<b>R</b> PEARL LIGHT BLUE TAMIYA TS-58
	<b>M</b> METAL FLAT STEEL F.S. 37178 ITALERI ACRYLCPAINT - 4679AP	
	<b>Q</b> GLOSS RED F.S. 11302 ITALERI ACRYLCPAINT - 4605AP	

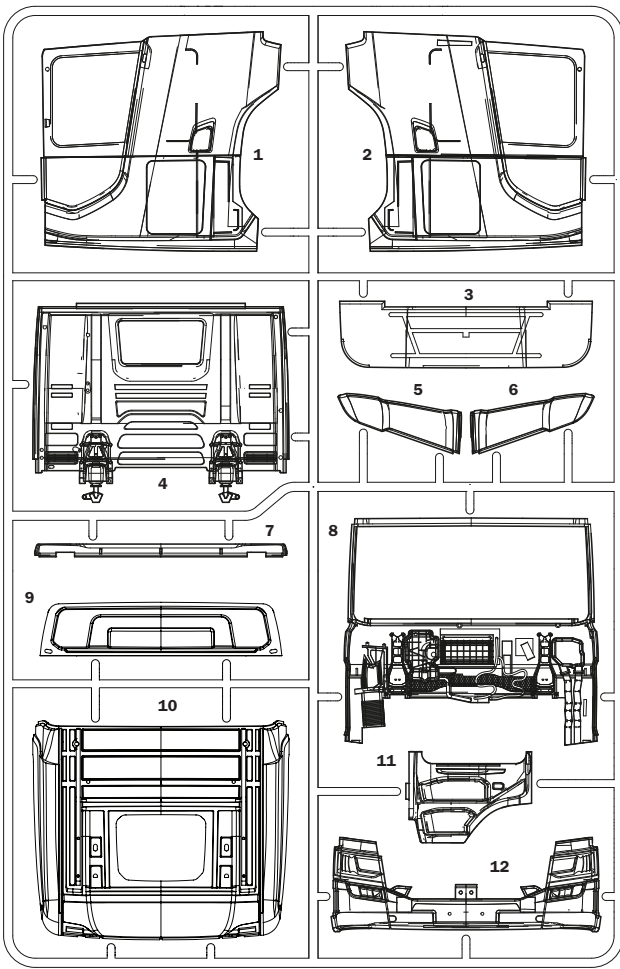
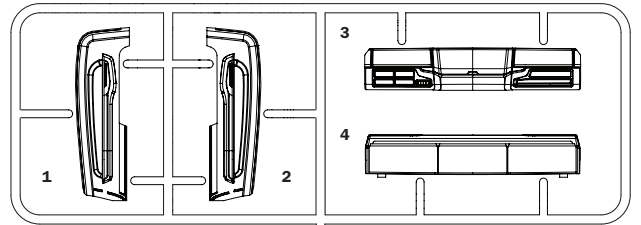
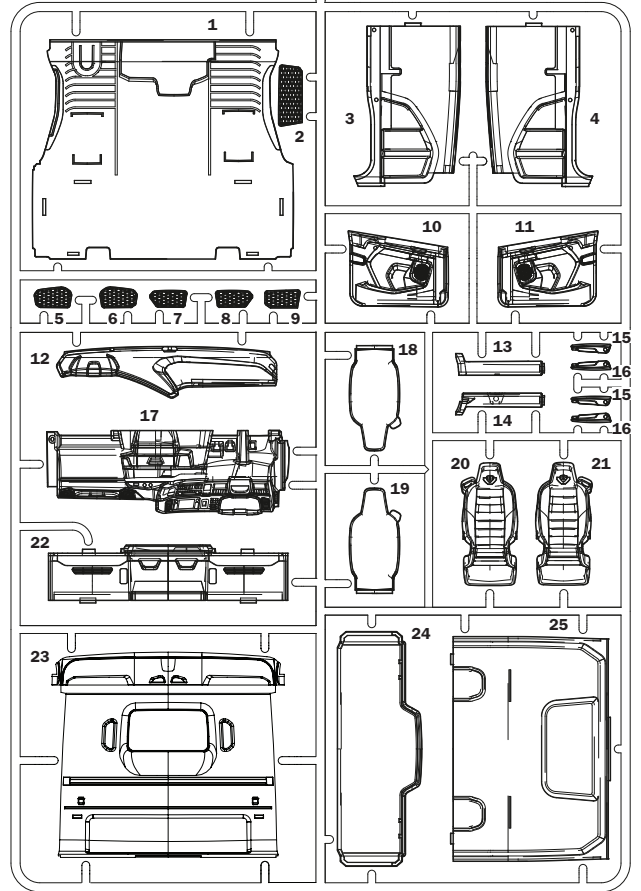
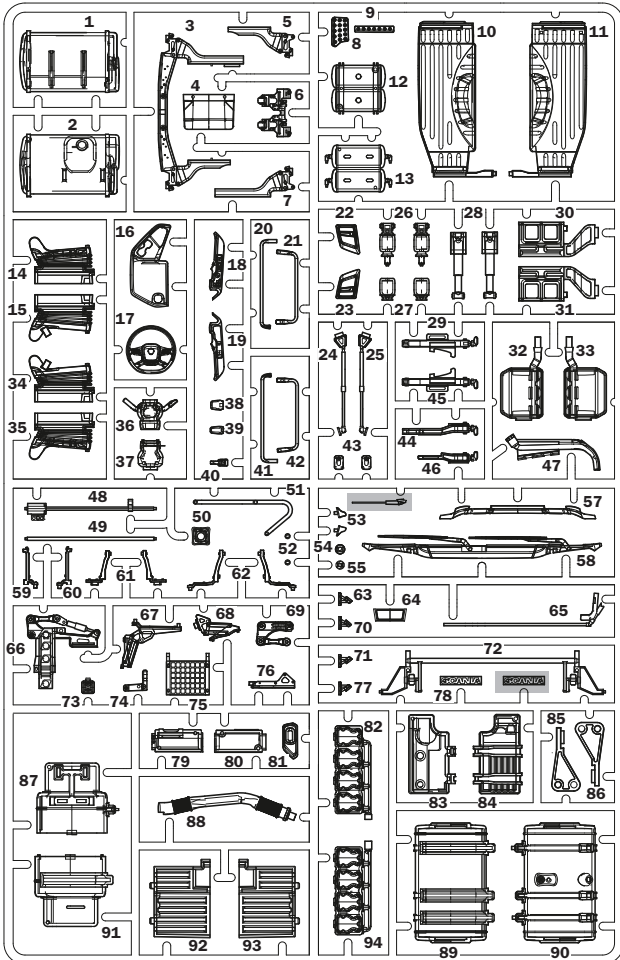
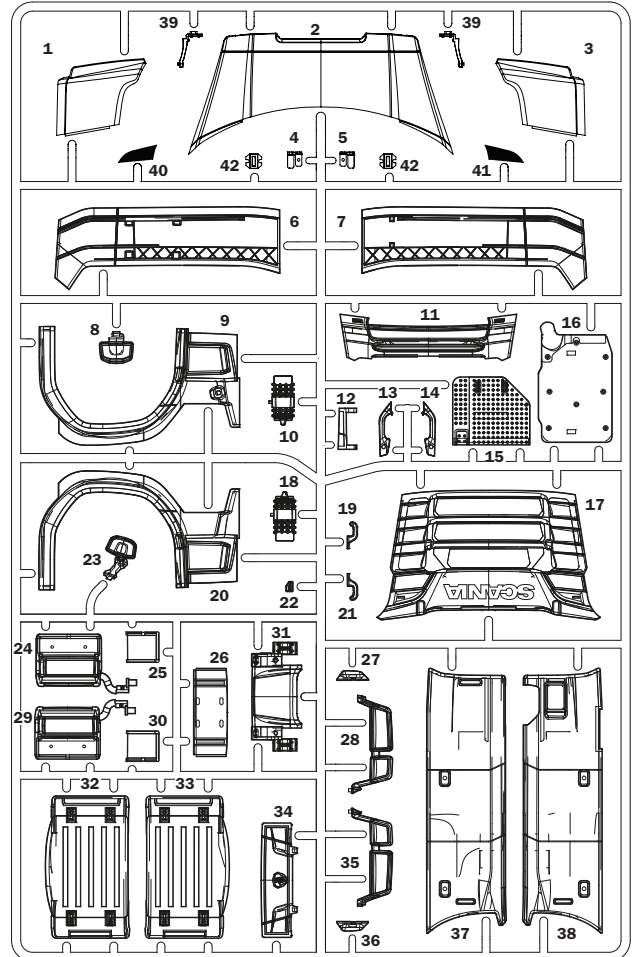
**C****E****D****F****G**

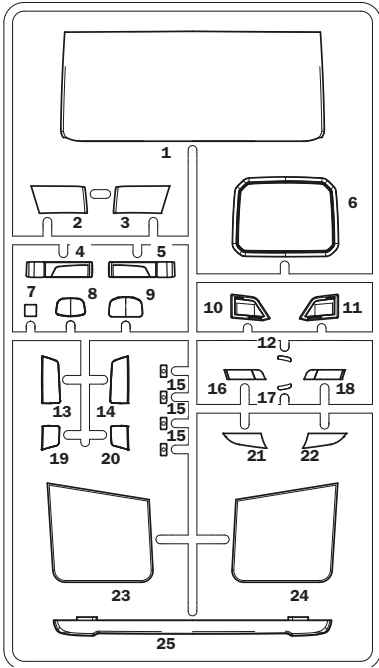
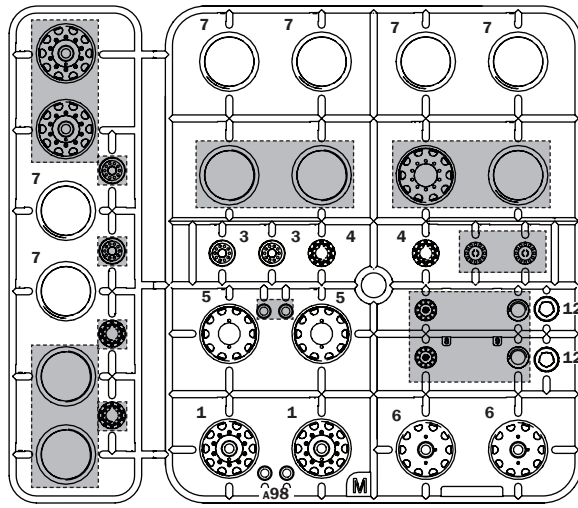
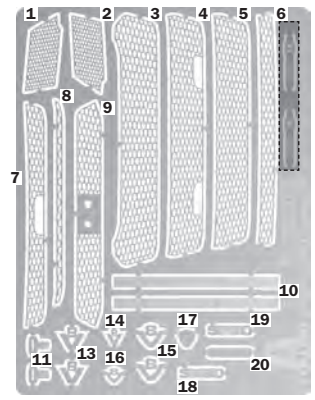
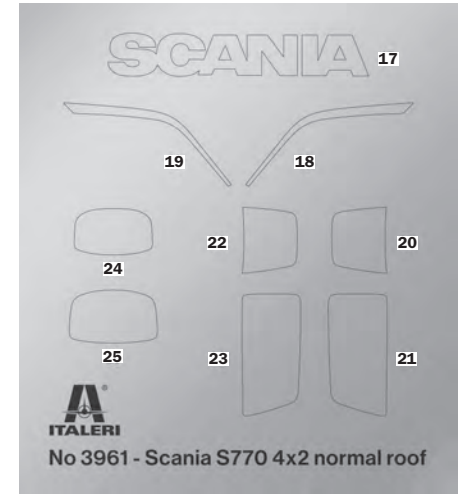
**H****M****PE****CA****CHROMED ADHESIVE****6x**

Parti da non utilizzare  
Parts not for use  
Pièces à ne pas utiliser  
Telle werden nicht verwenden

Separare  
Cut  
Retirer  
Entfernen

Aprire i fori  
Drill holes  
Ouvrir les trous  
Die Locher ausbohren

Ribadire a caldo  
Rivet hot  
River à chaud  
Warm ennieten

## CHOOSE VERSION BEFORE ASSEMBLY

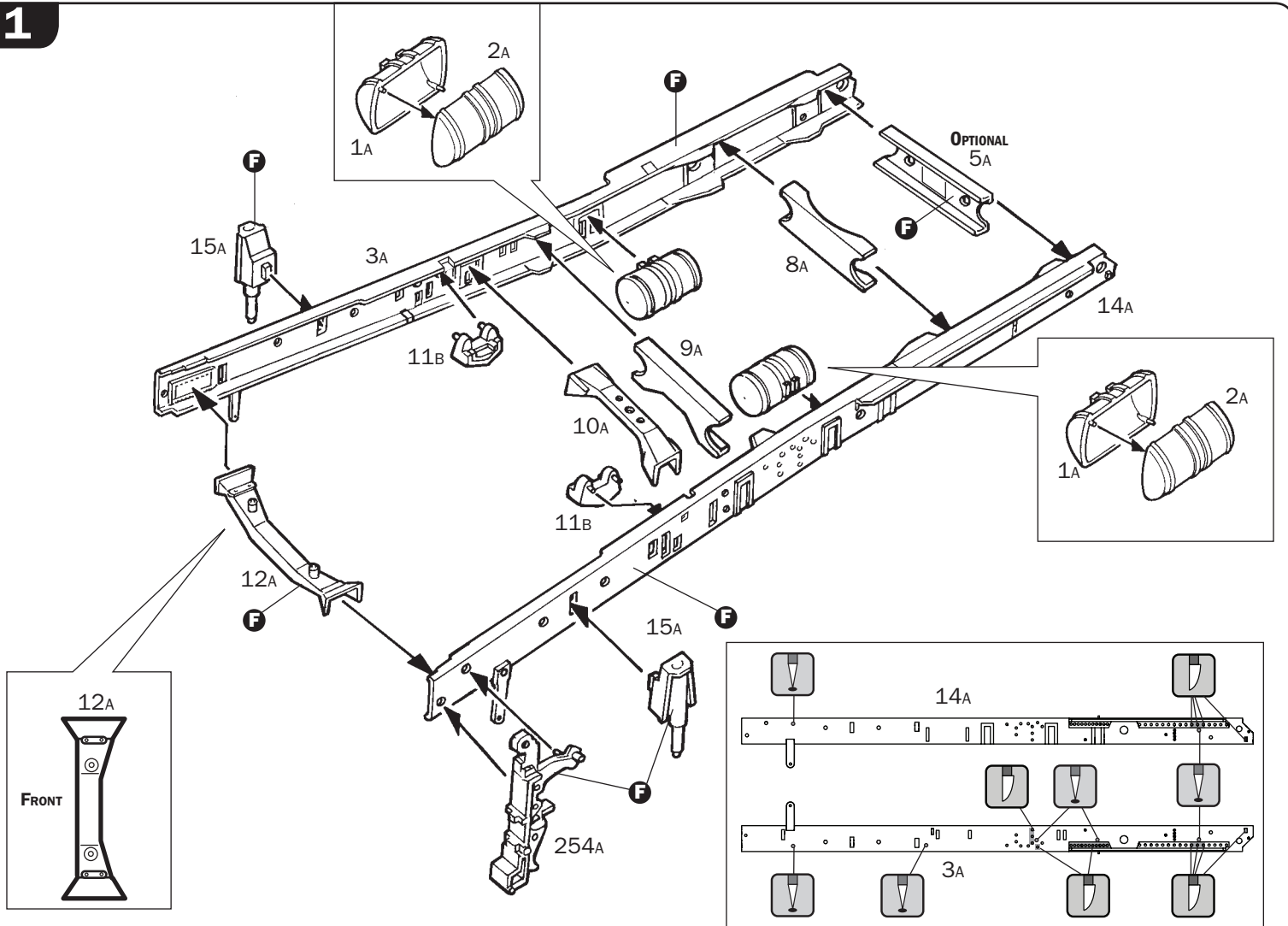
**1**

# 2

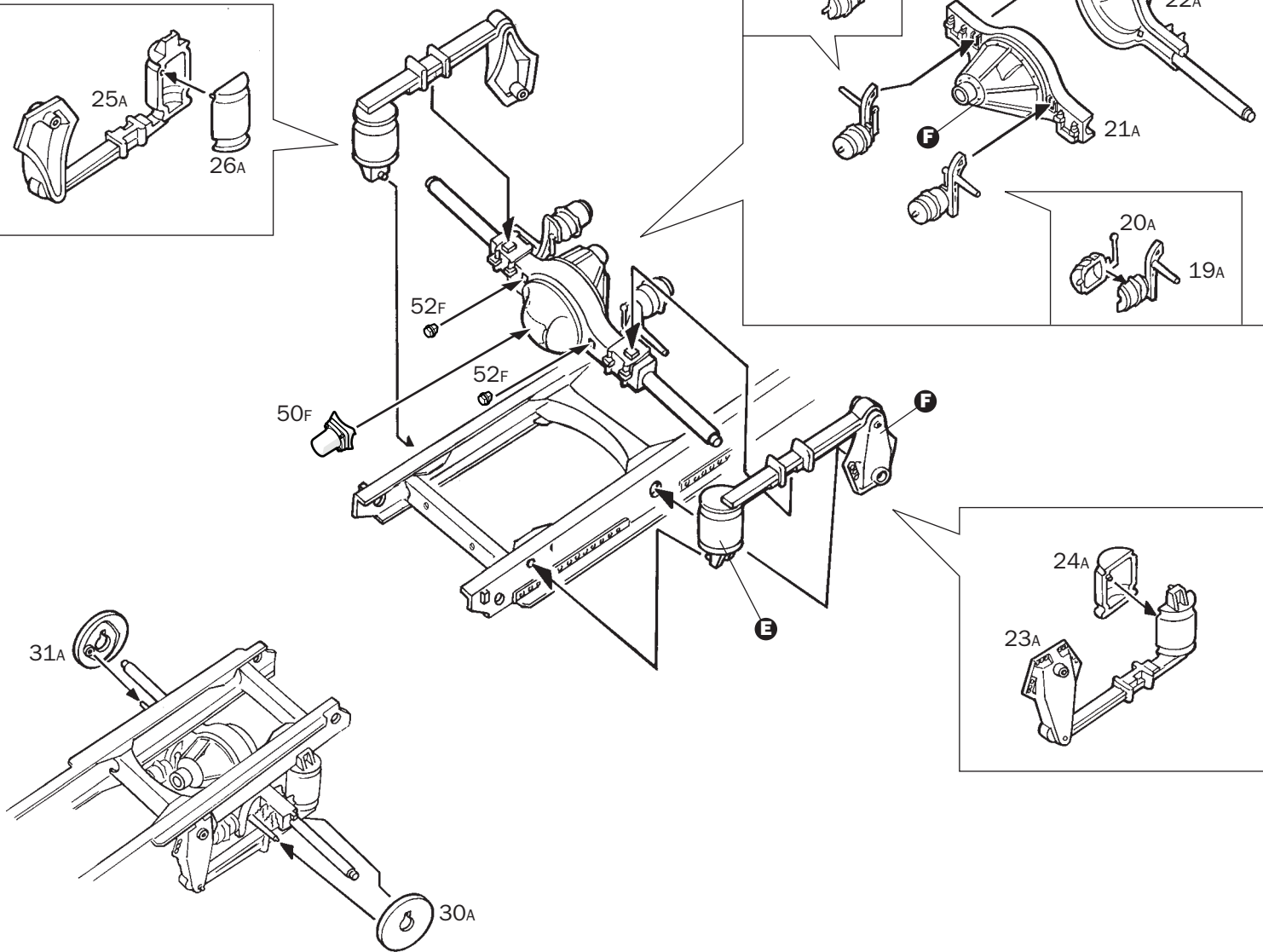

# 3

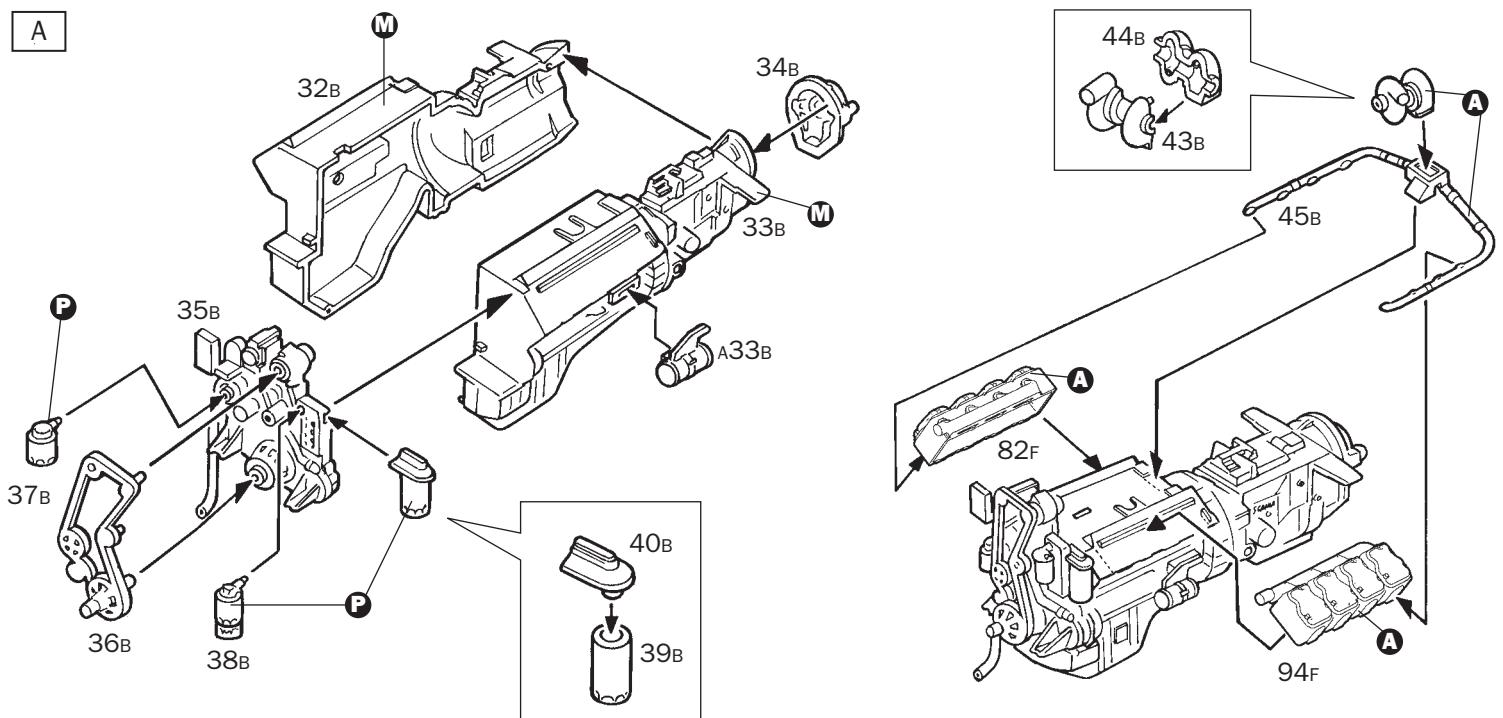

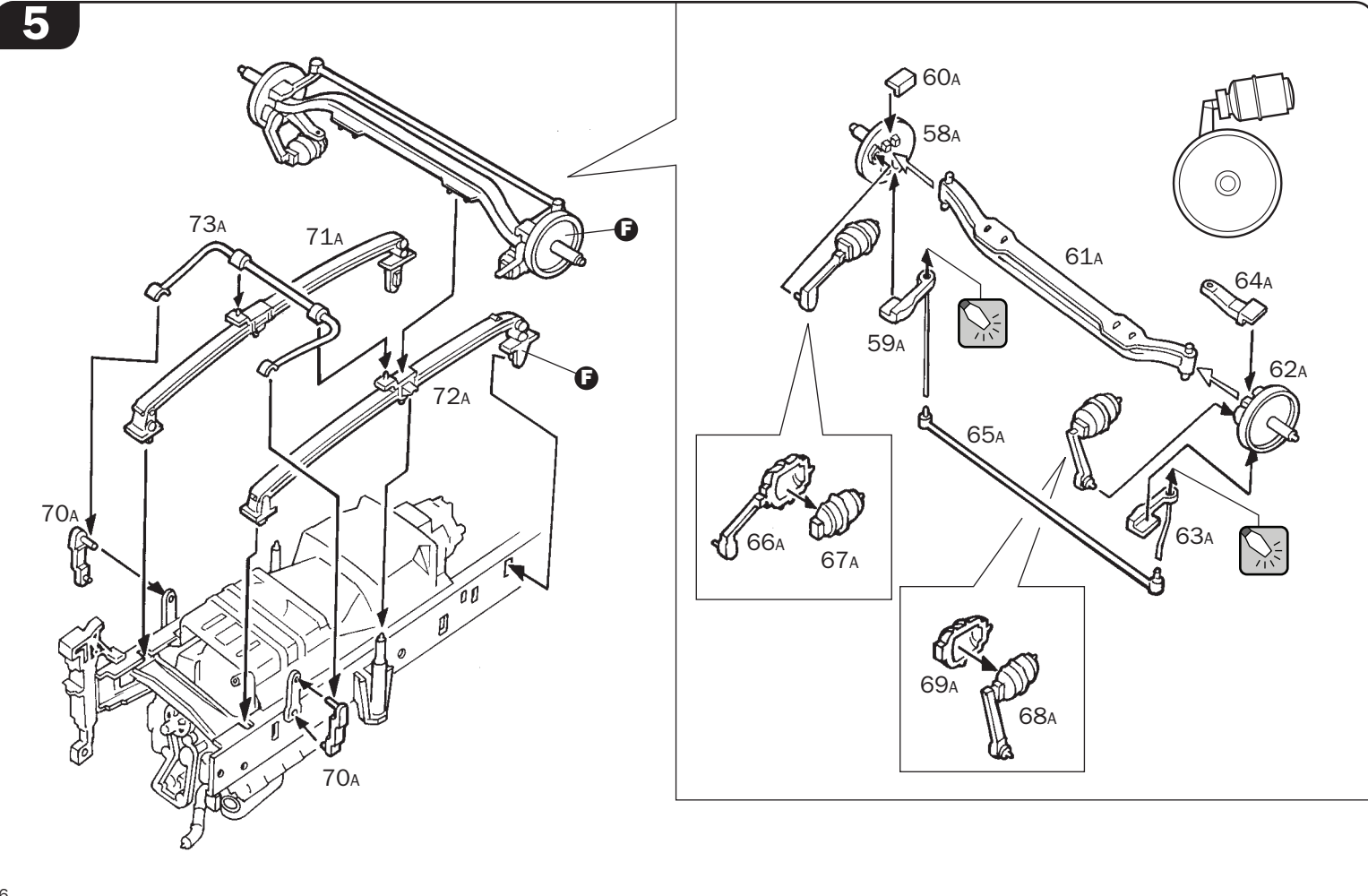
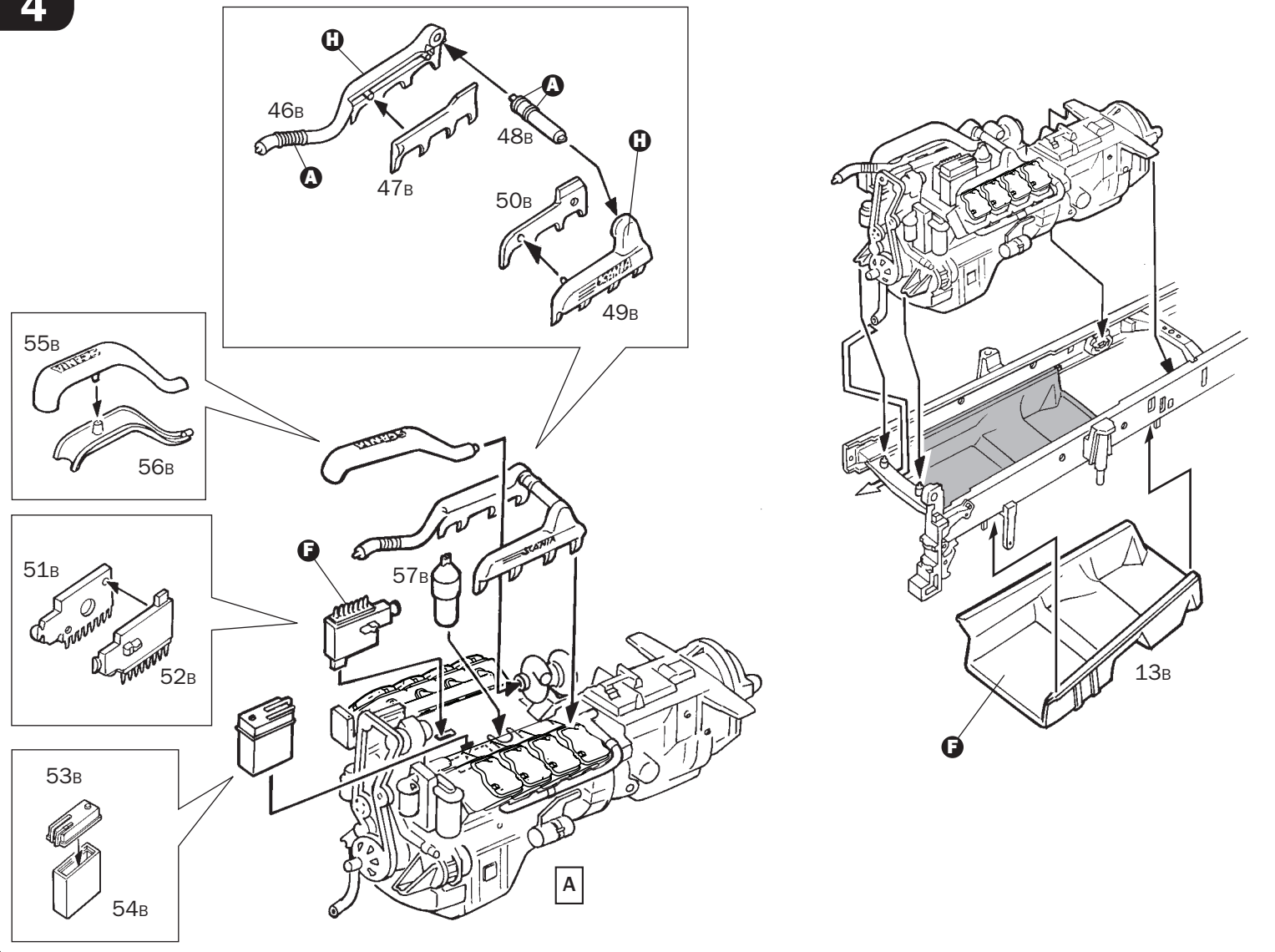

6

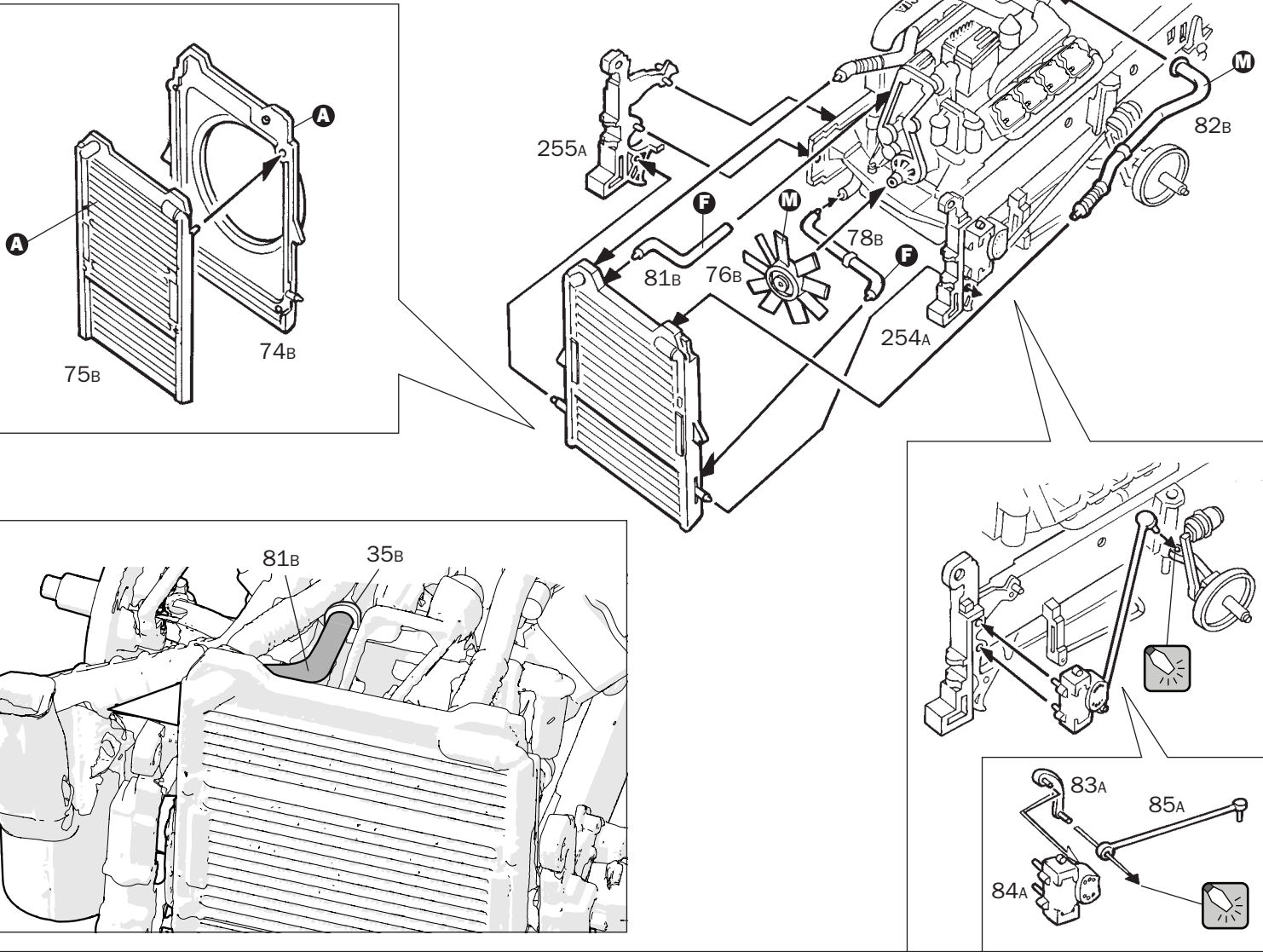

7

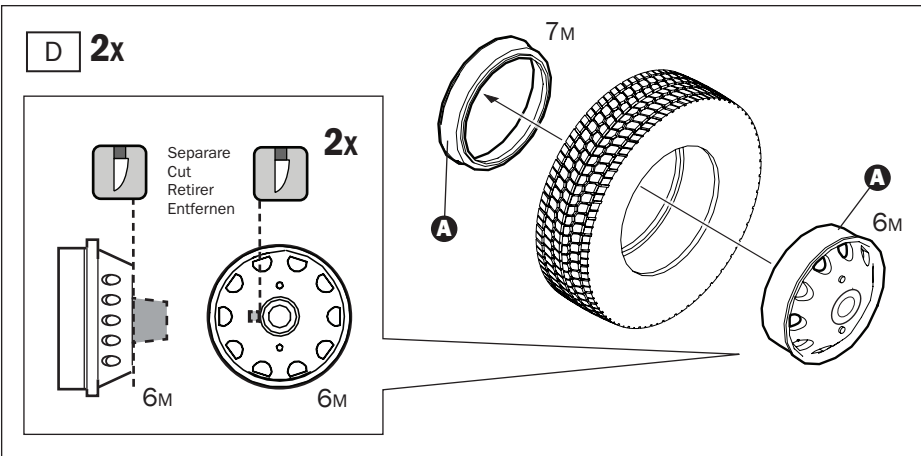
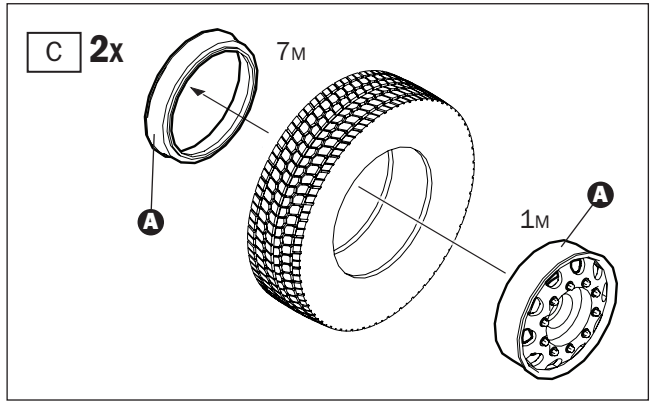
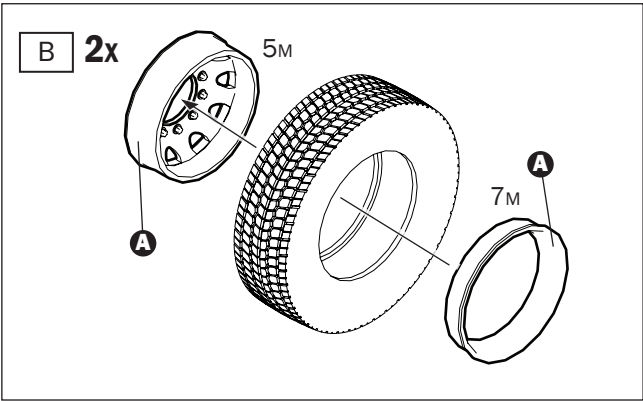

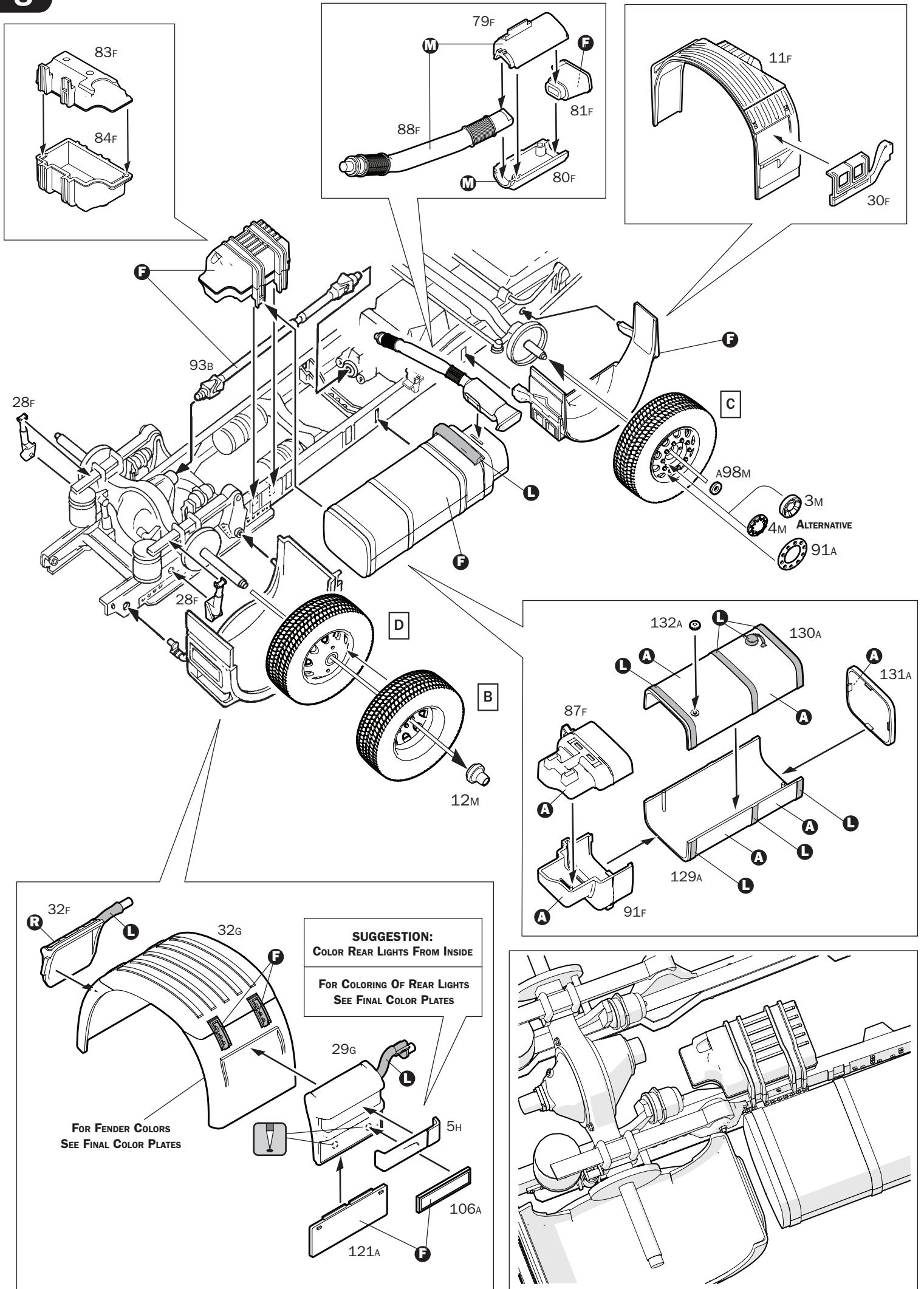

**SUGGESTION:**  
 COLOR REAR LIGHTS FROM INSIDE  
 FOR COLORING OF REAR LIGHTS  
 SEE FINAL COLOR PLATES

FOR FENDER COLORS  
 SEE FINAL COLOR PLATES

FOR FENDER COLORS  
 SEE FINAL COLOR PLATES



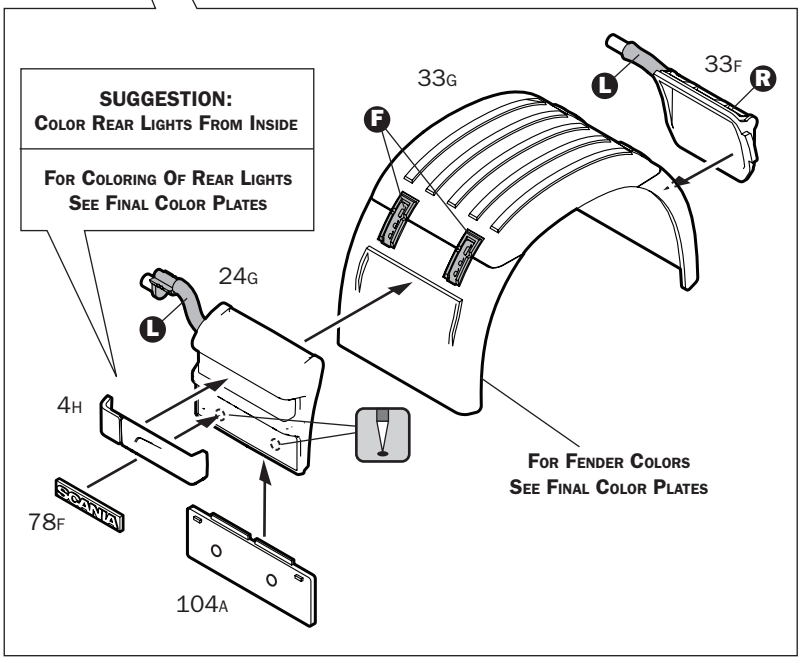
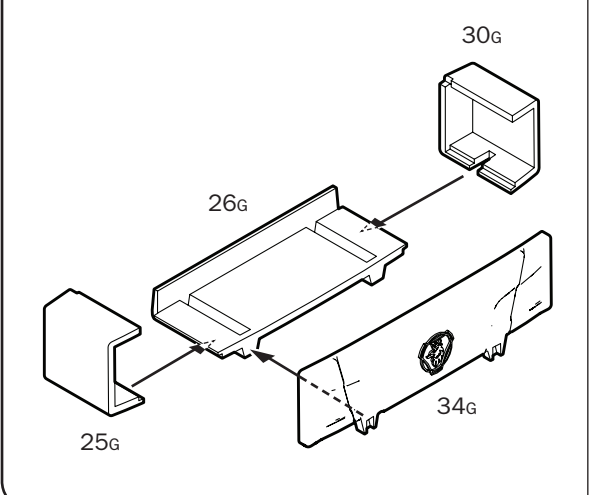
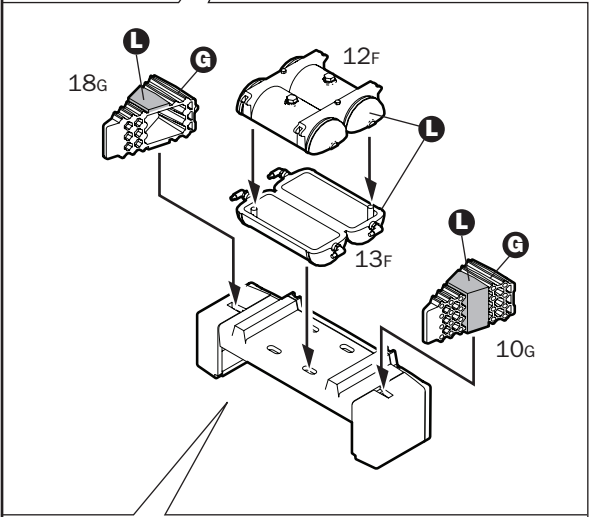
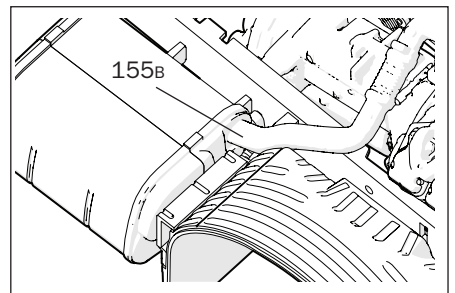
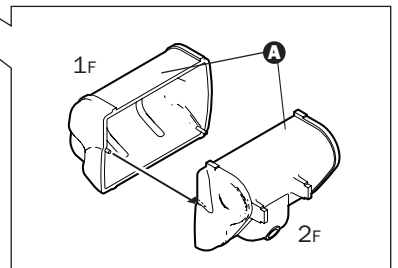
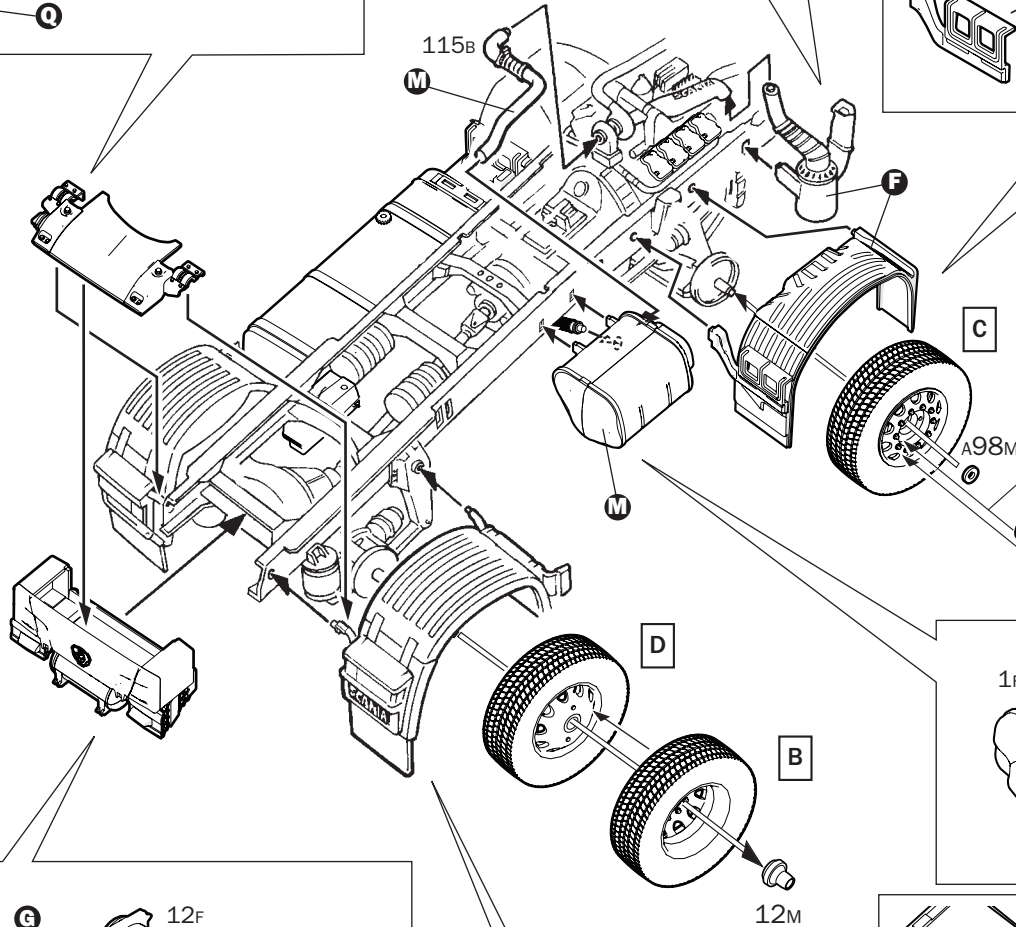
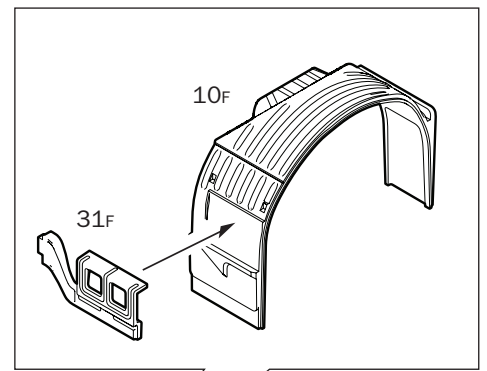
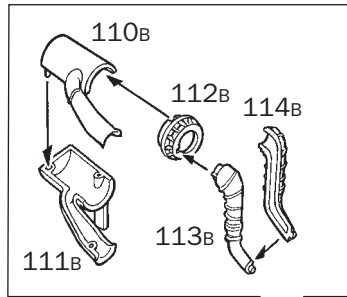
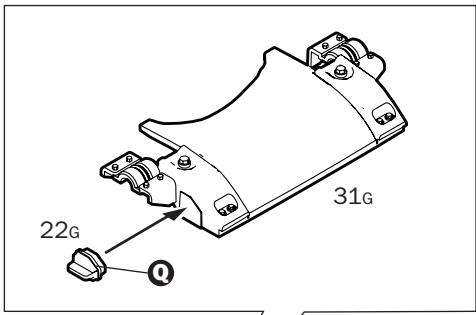

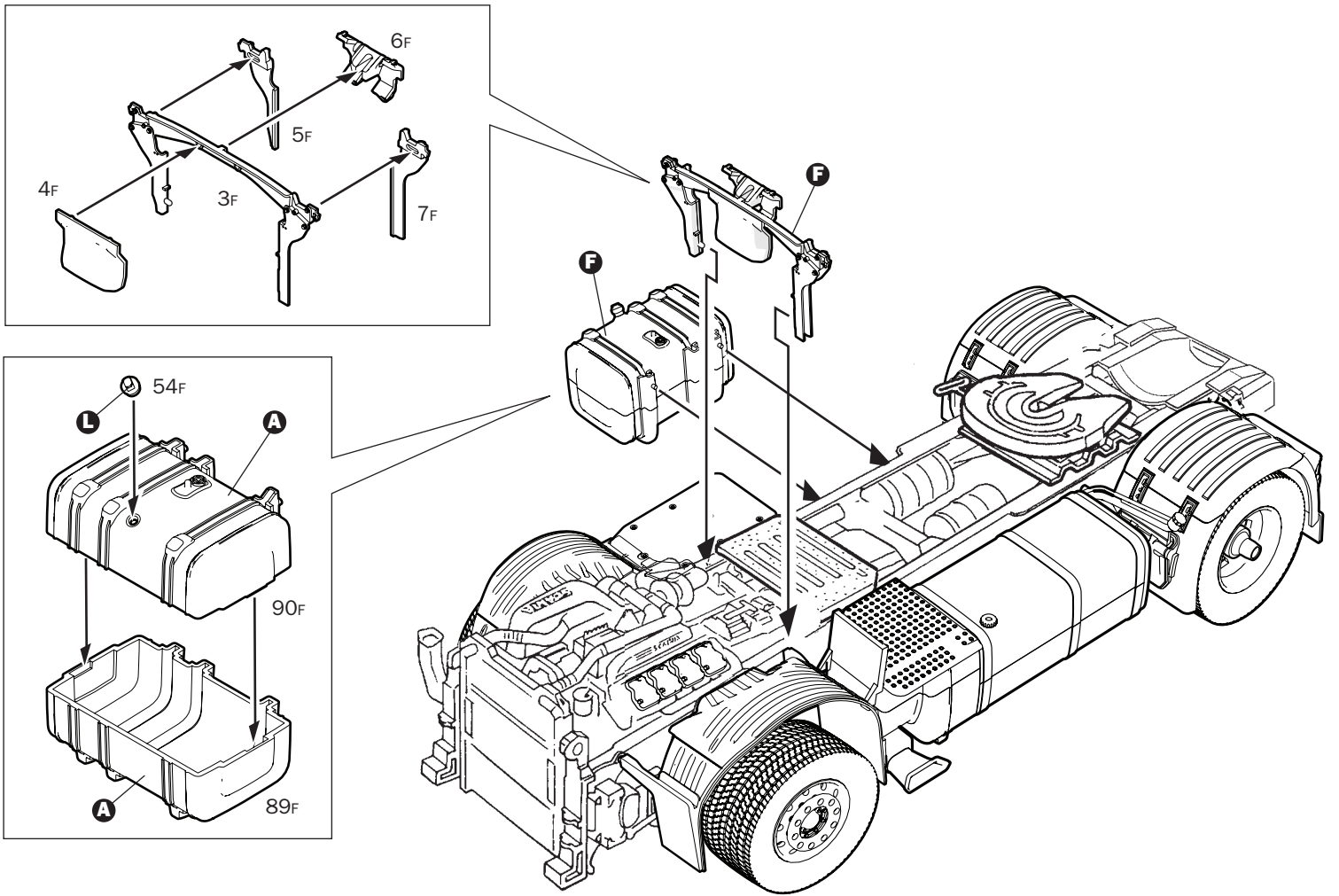
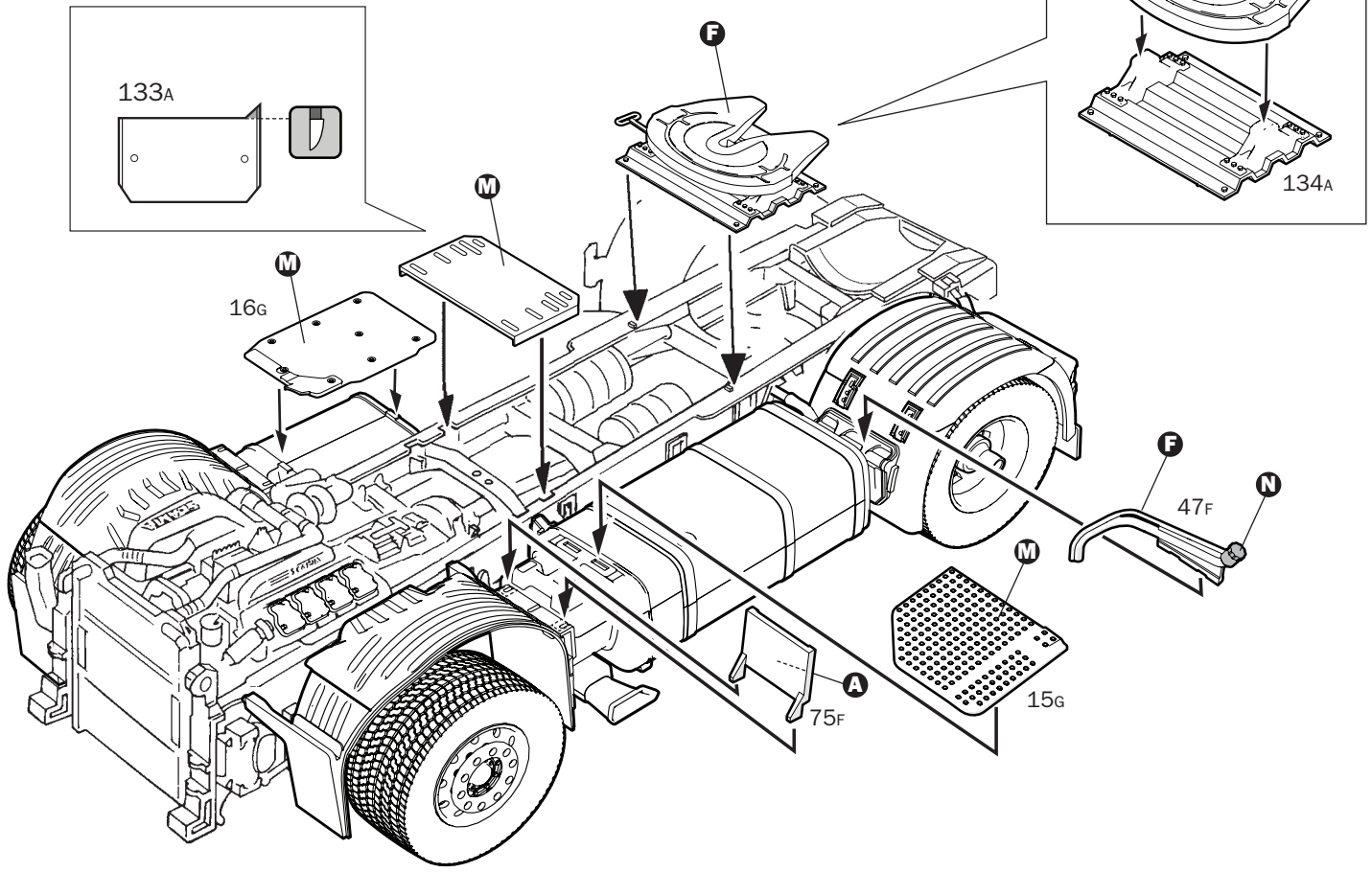

# 12

E

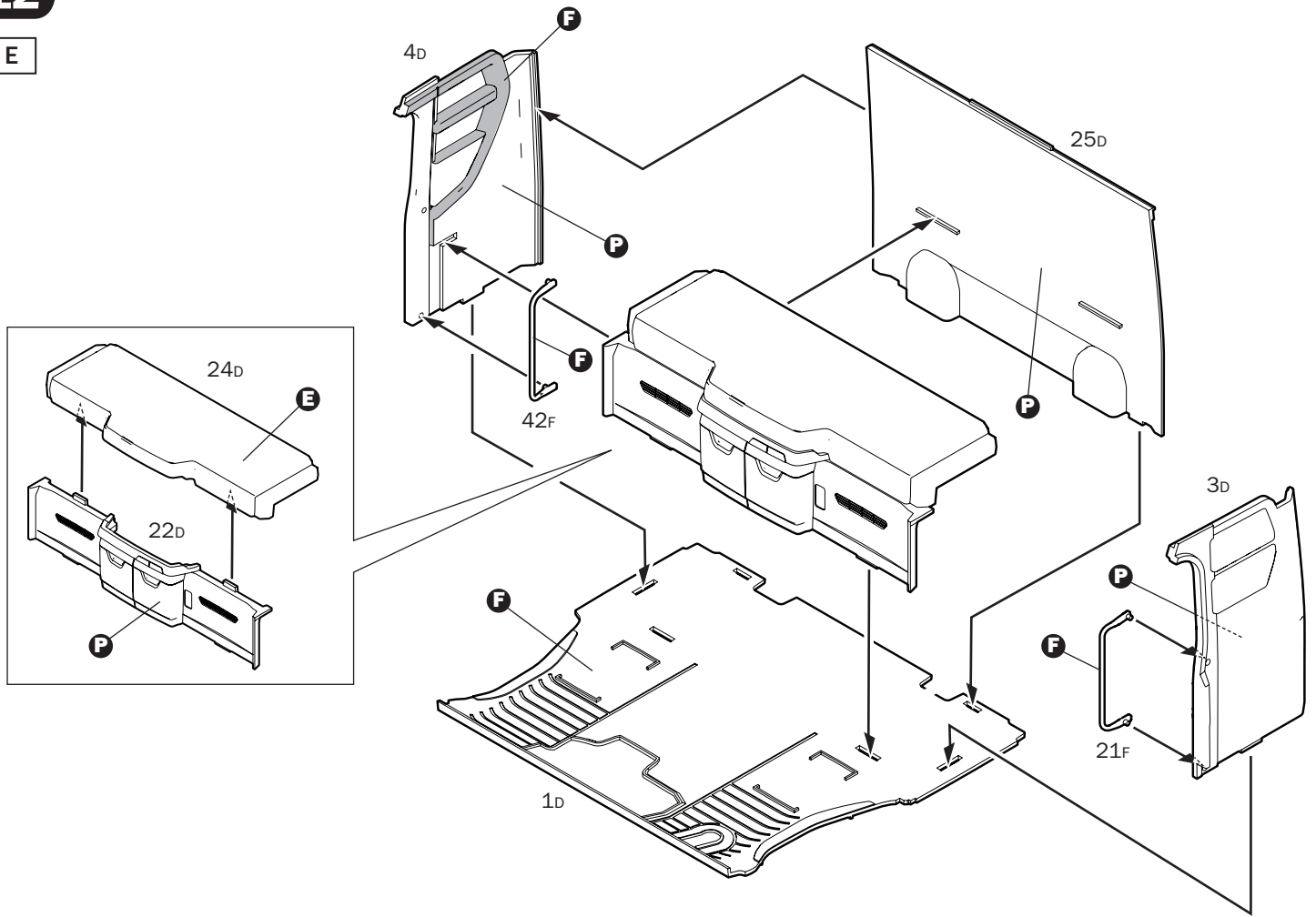

# 13

F

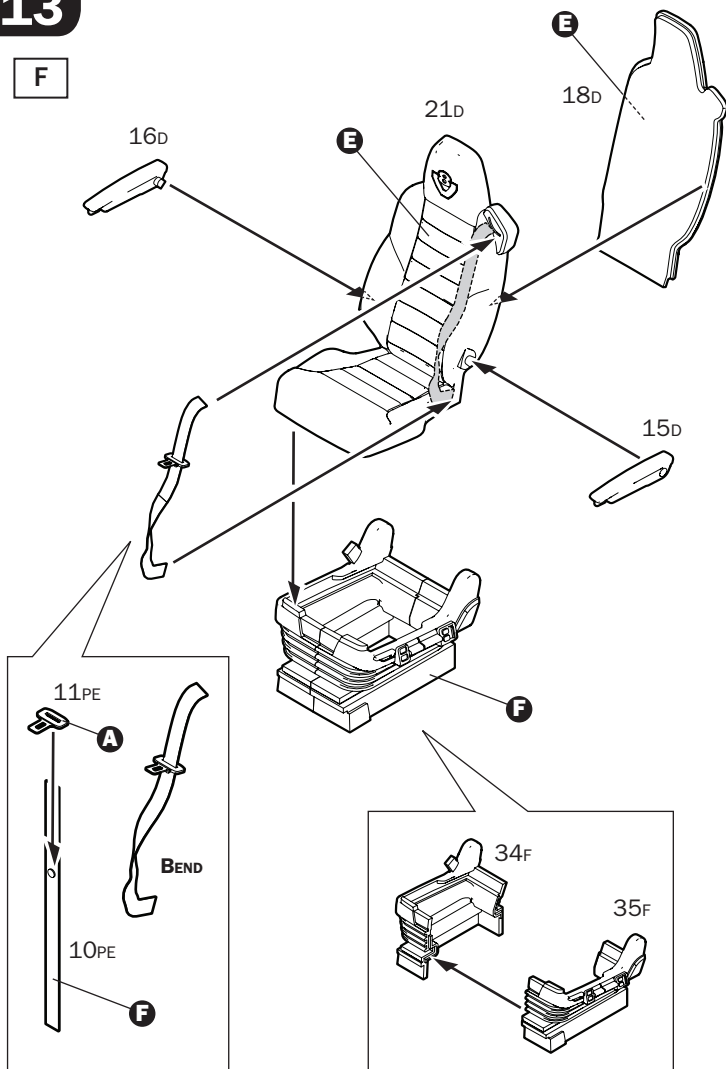

G

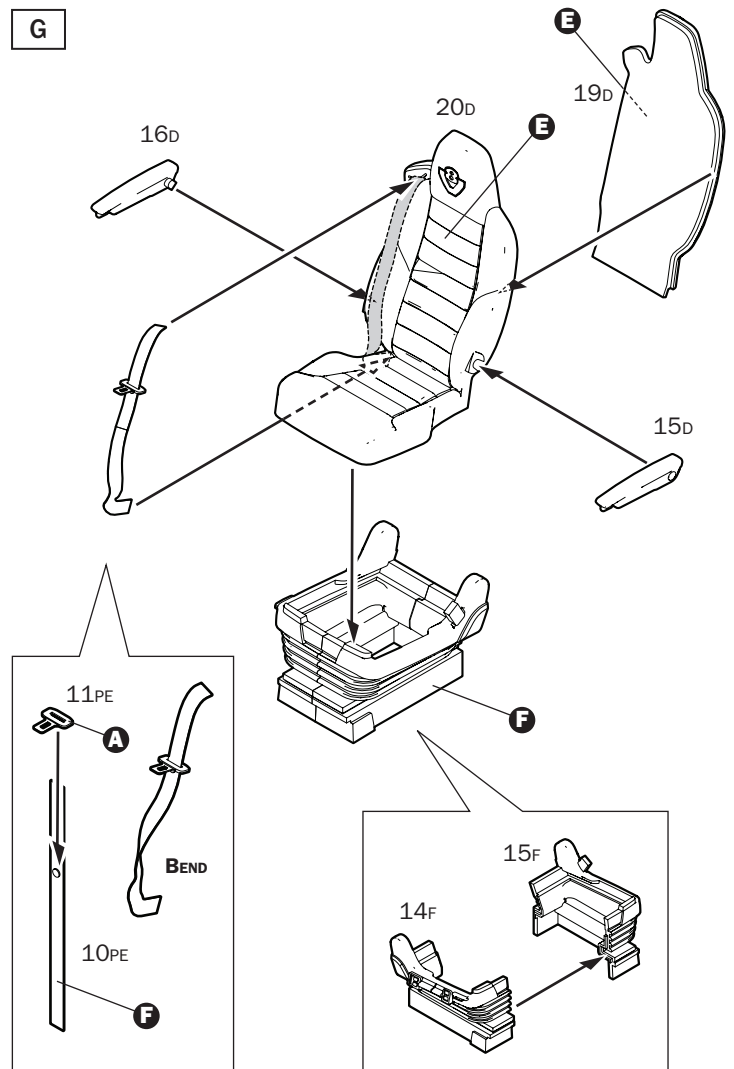

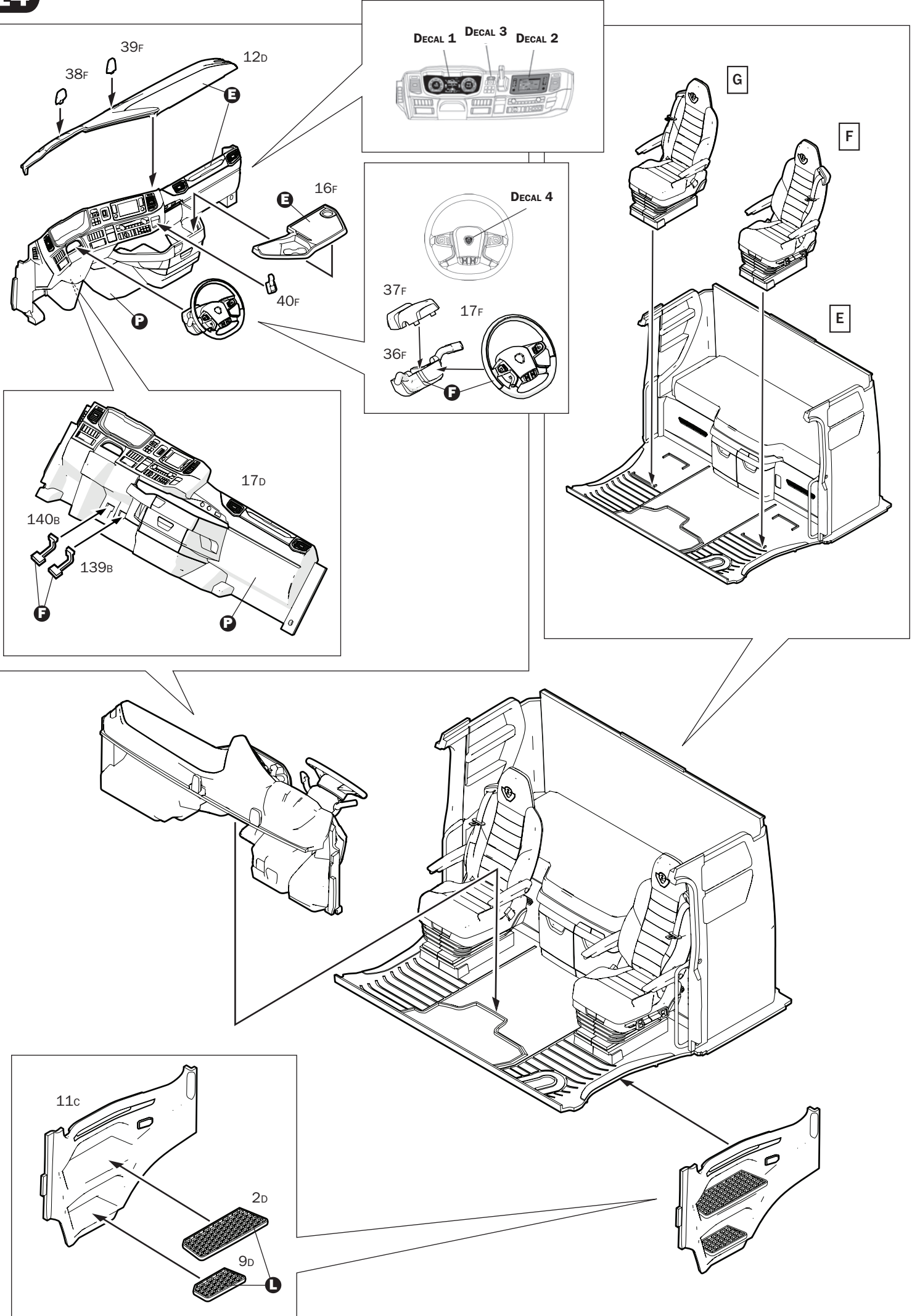

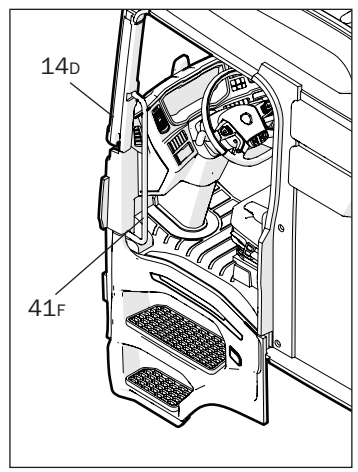
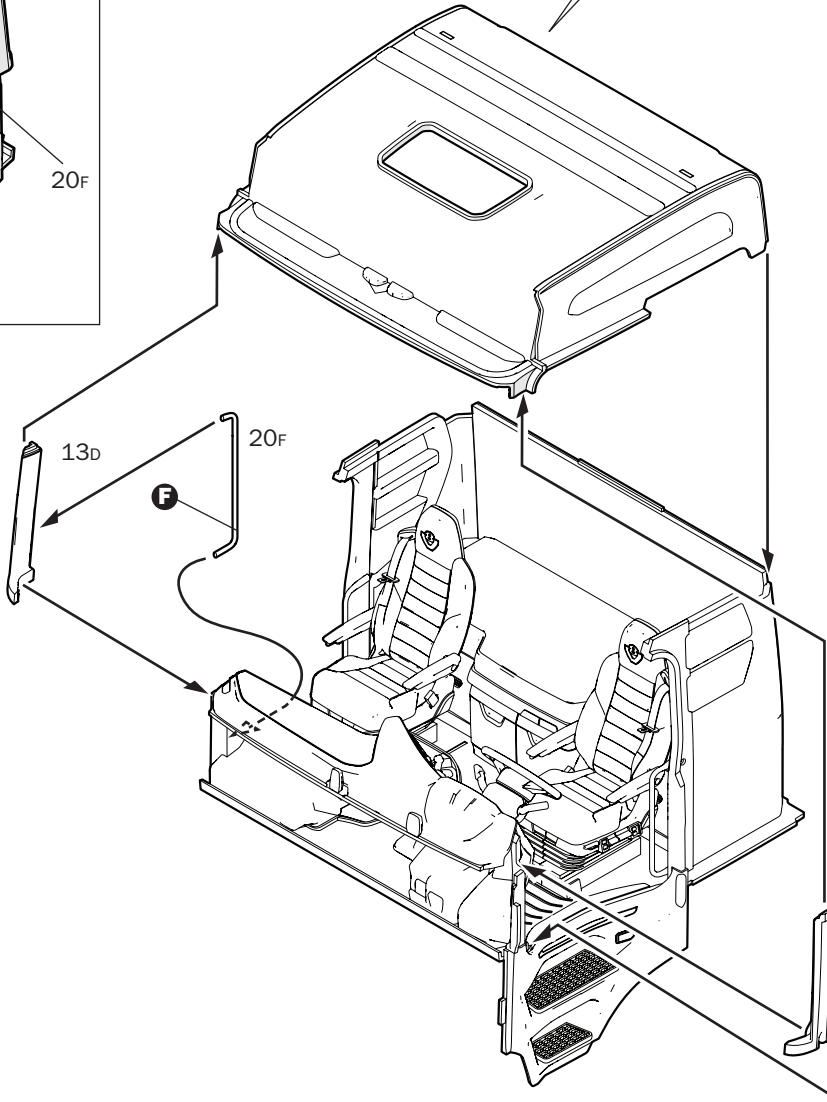
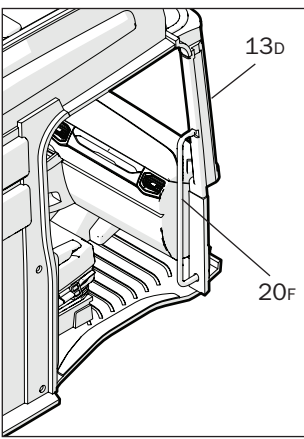
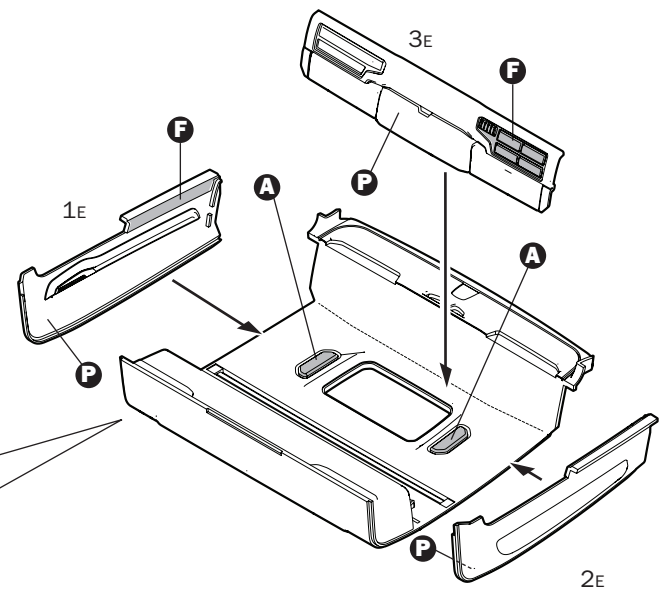
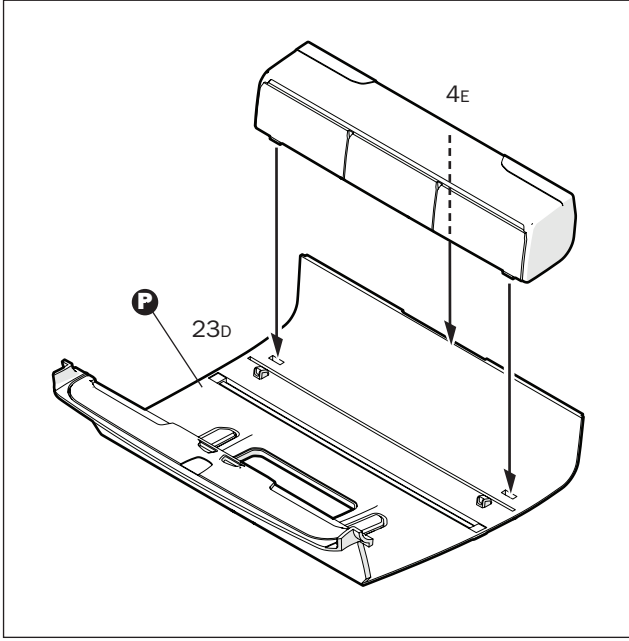

**16** CLOSED VERSION

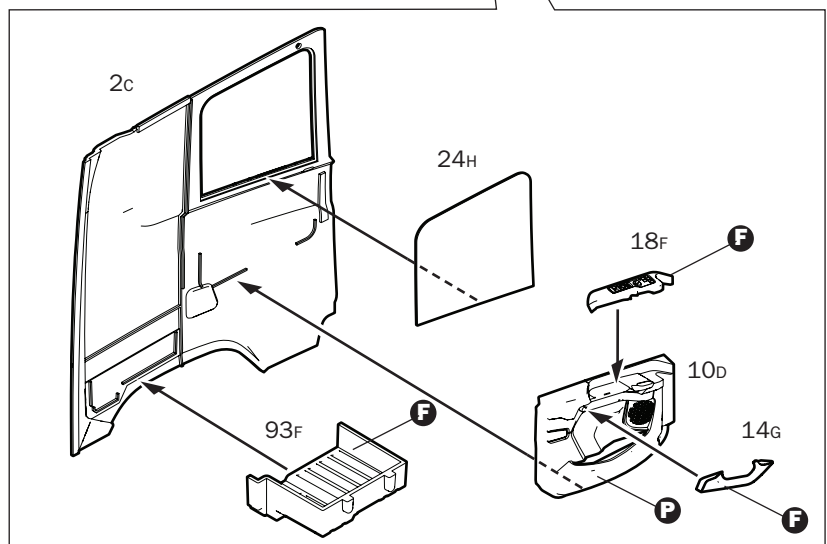
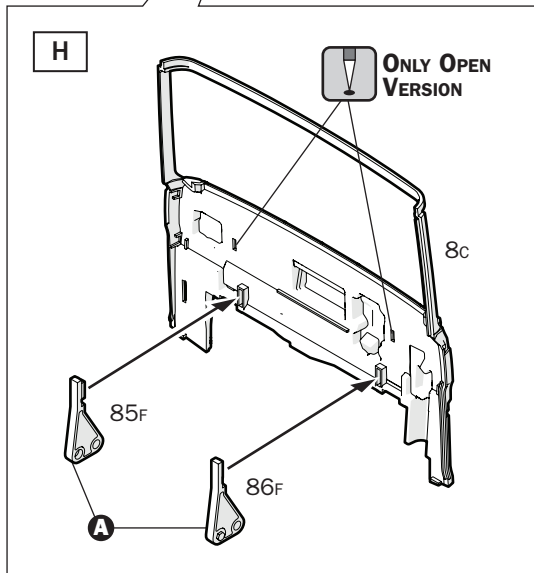
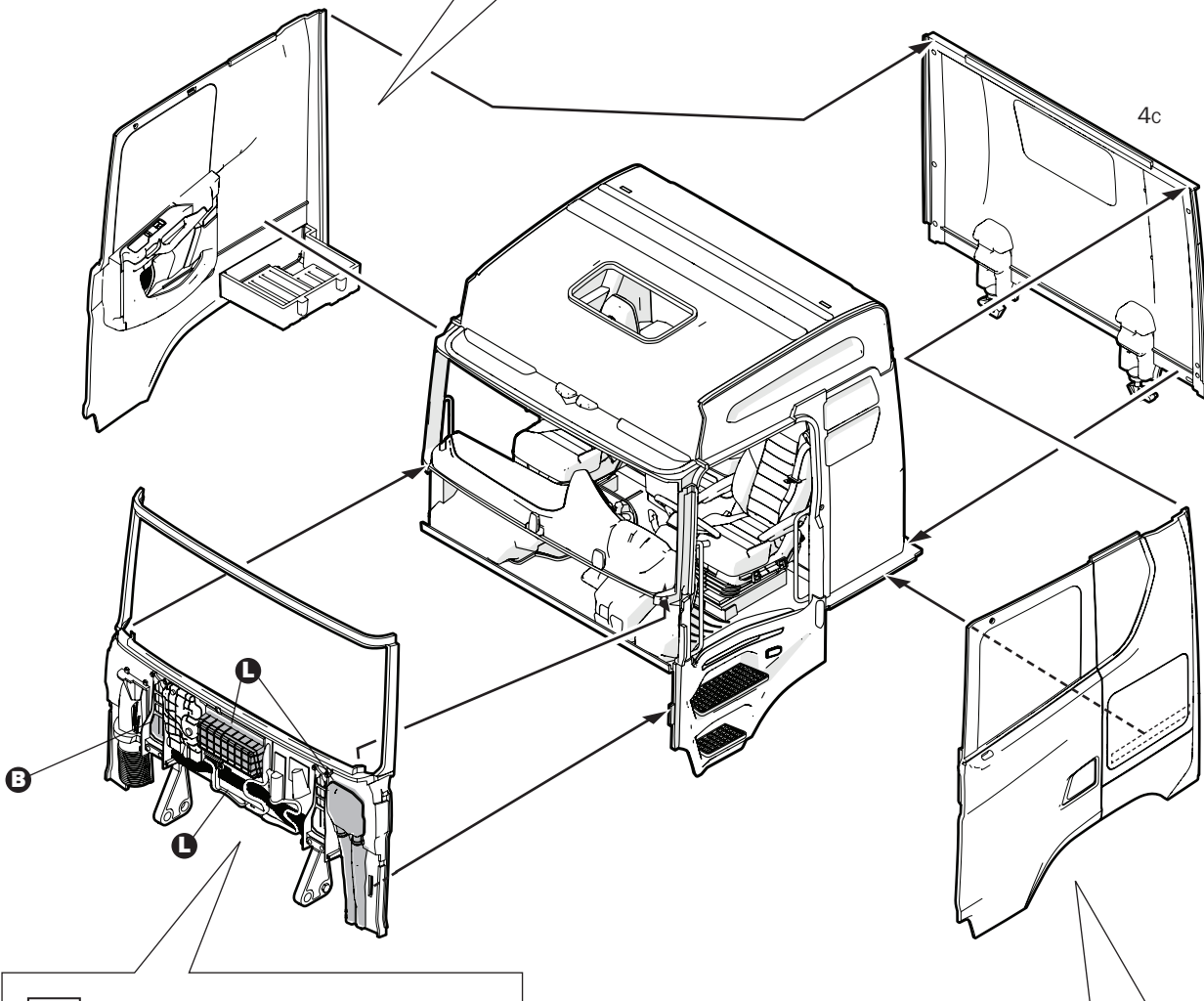
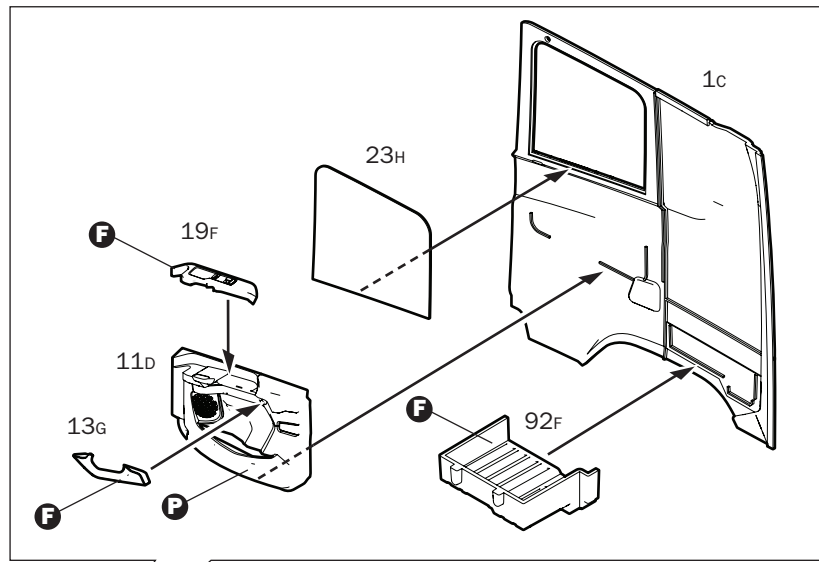

# 17 OPEN VERSION

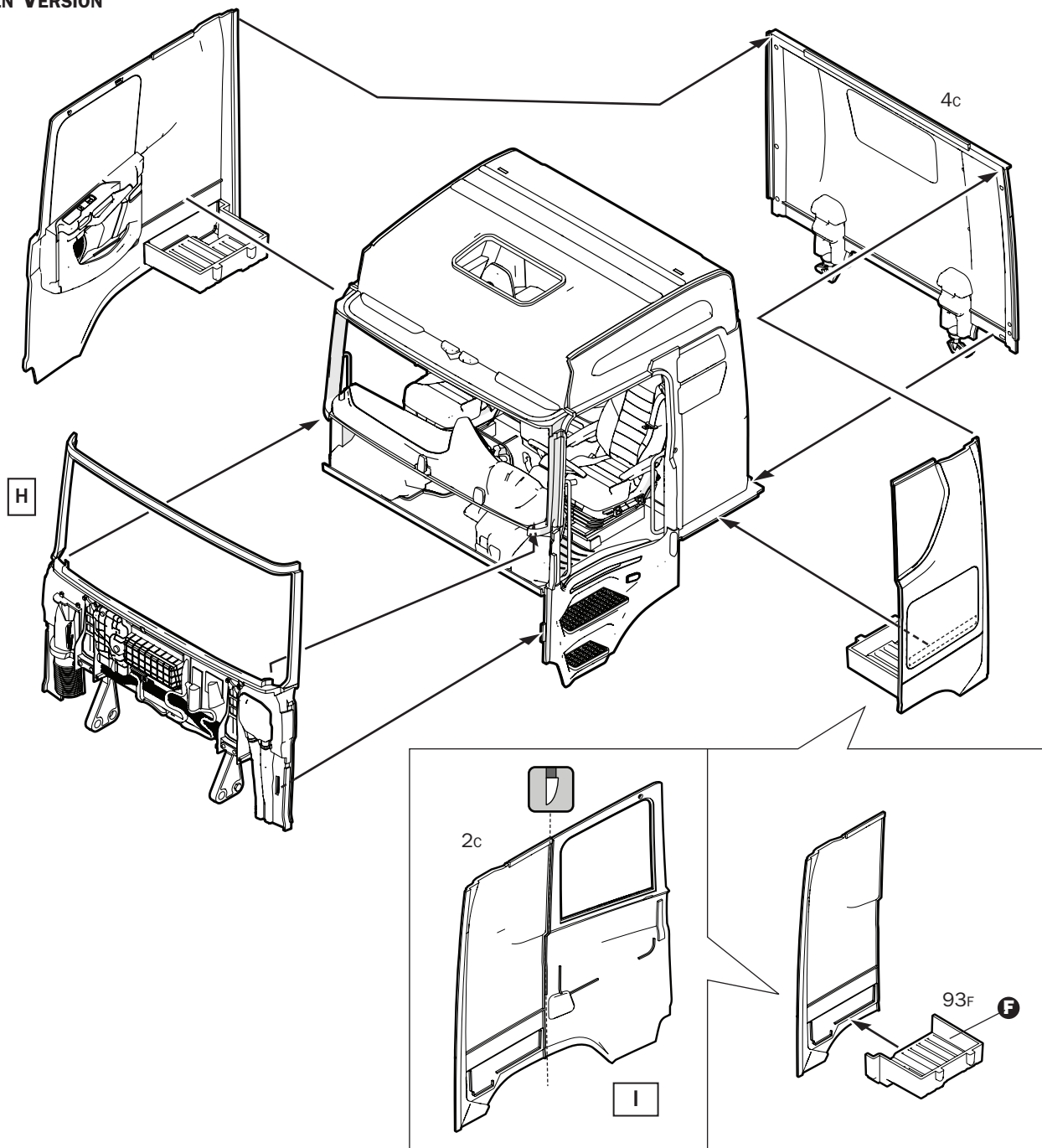

# 18

L

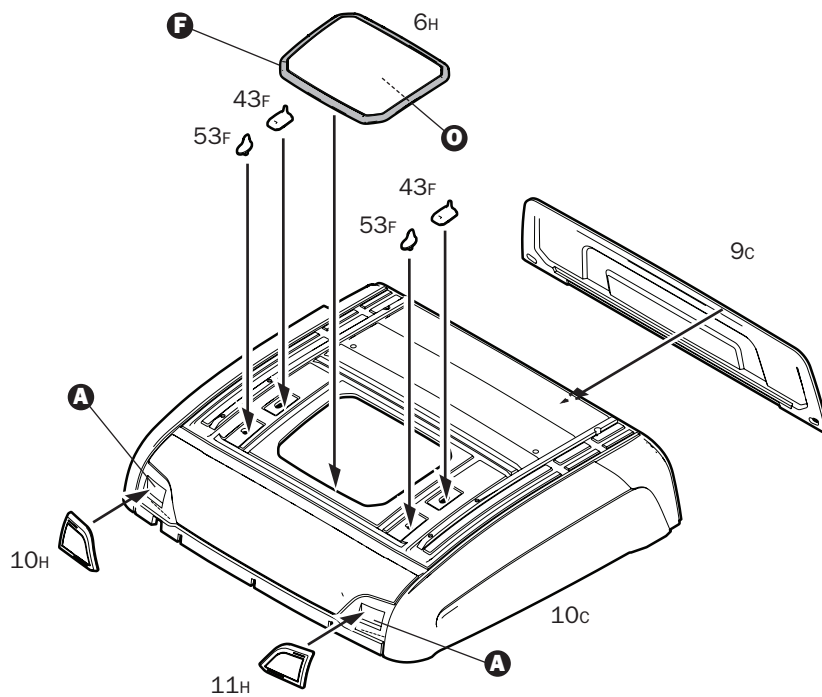

19

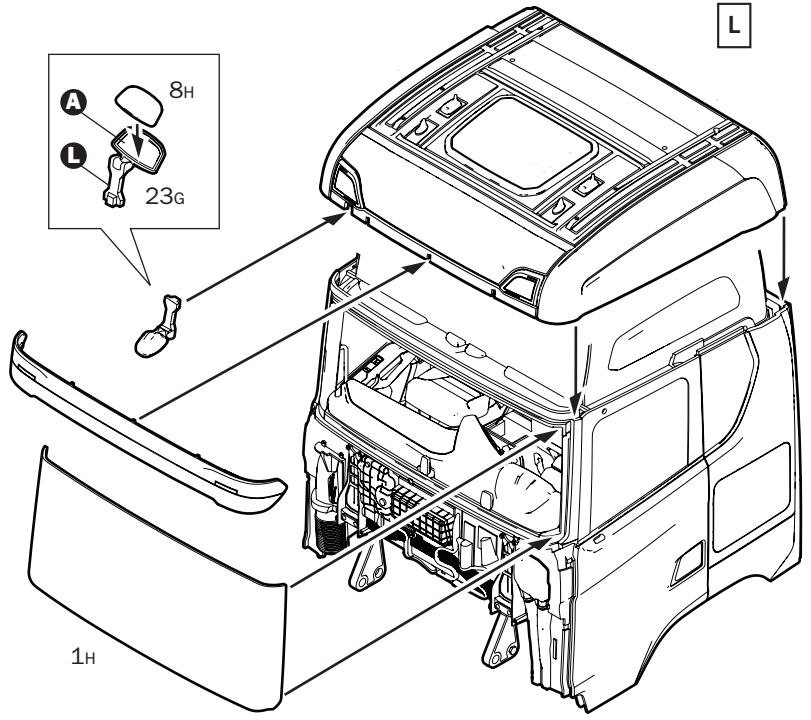
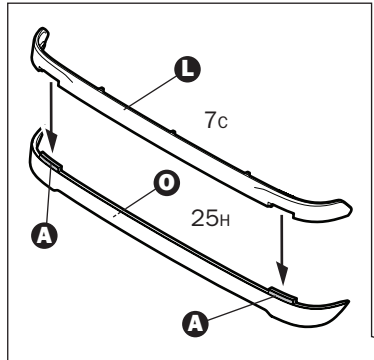

20

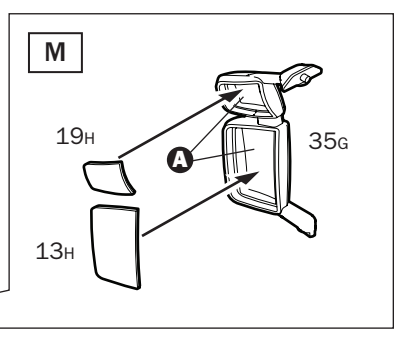
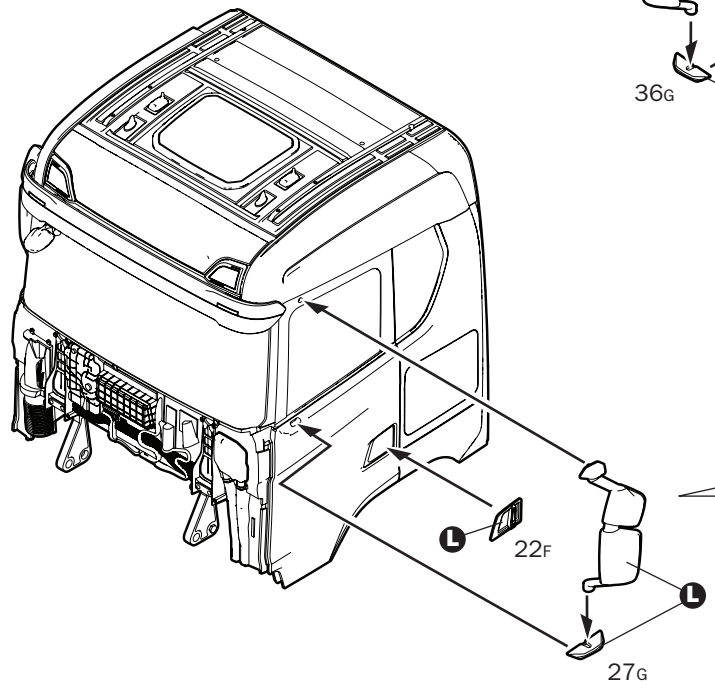
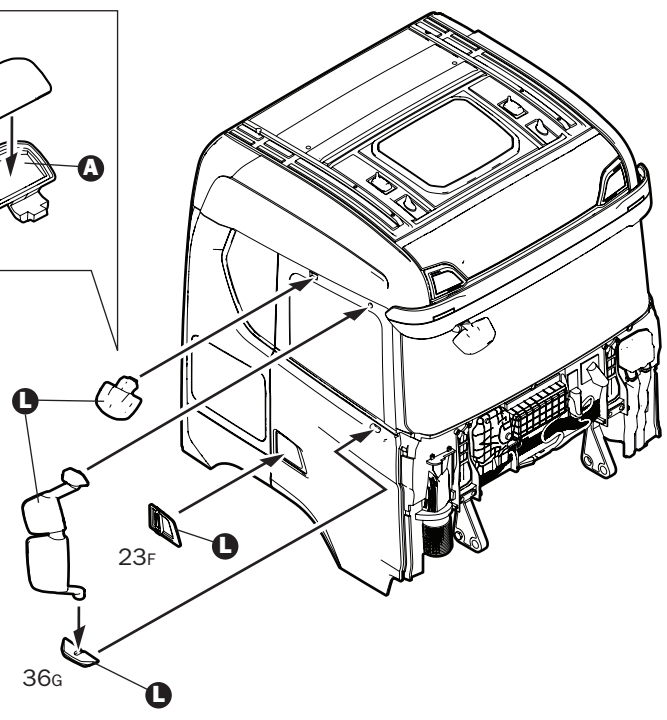
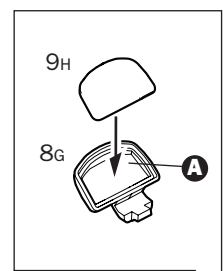
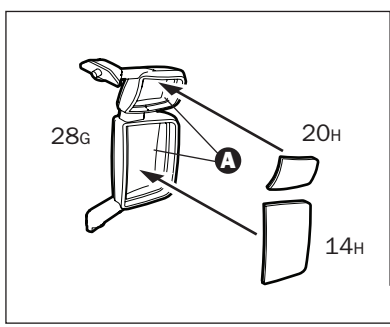



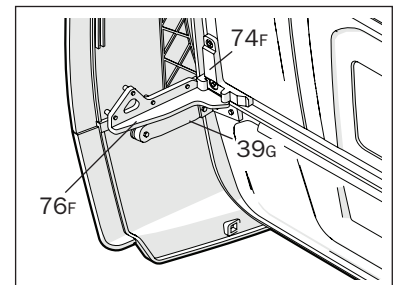
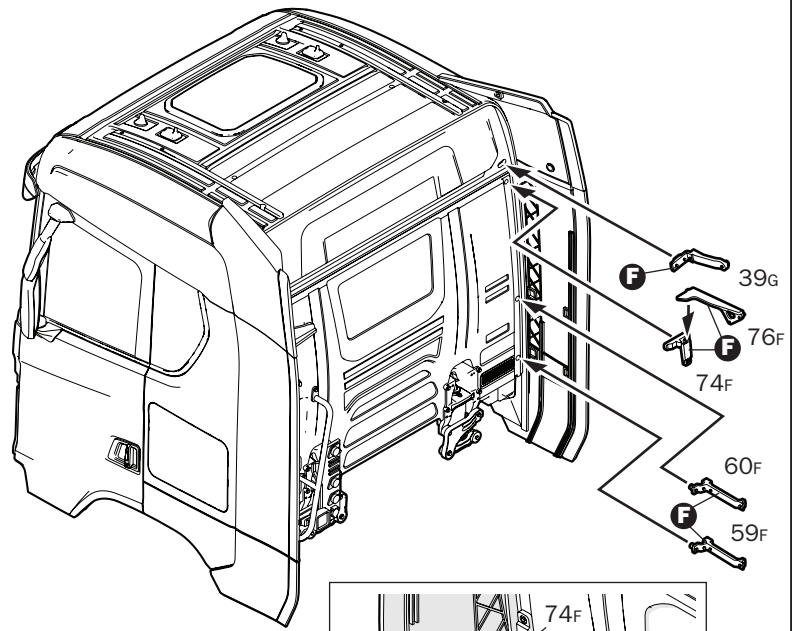
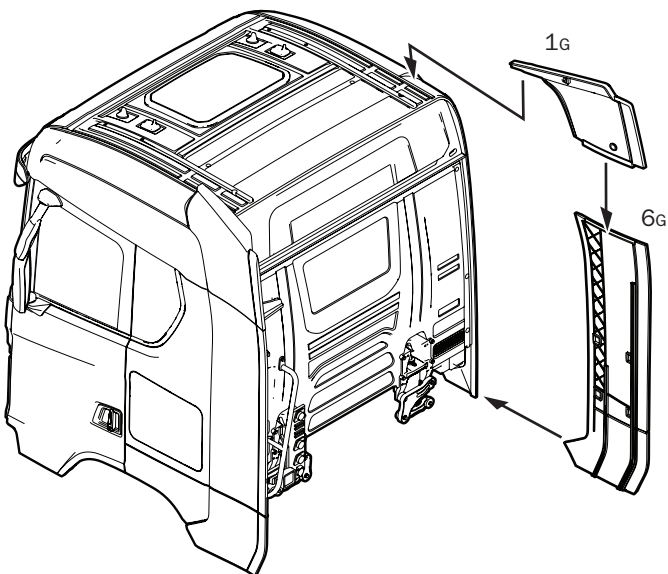
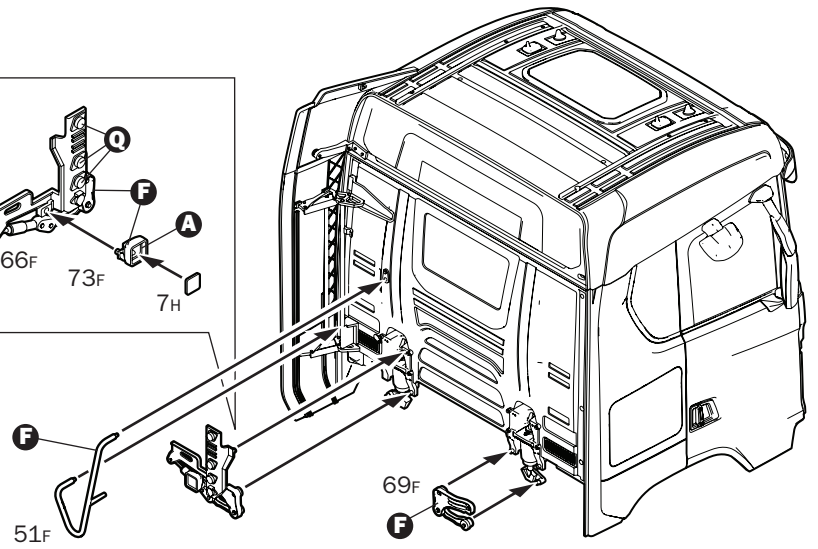
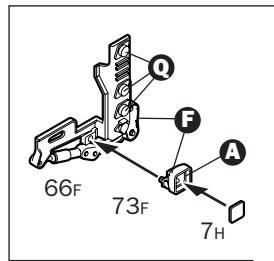
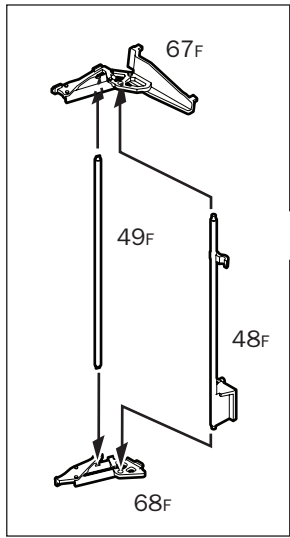
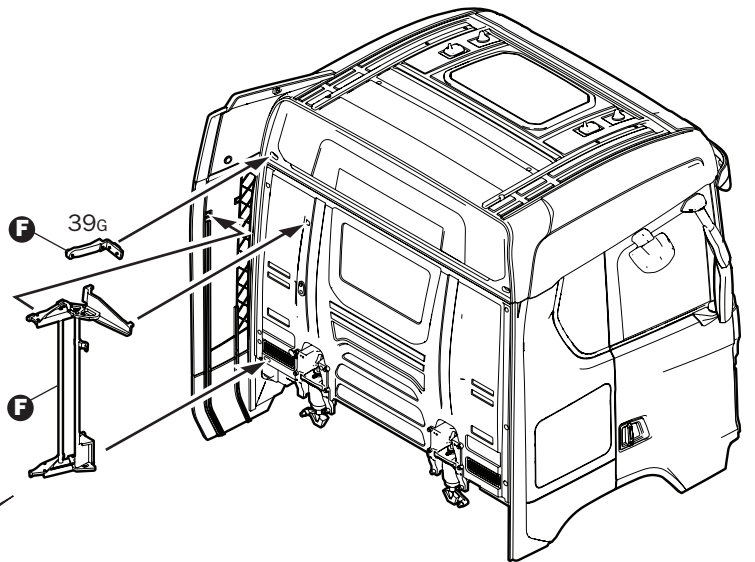
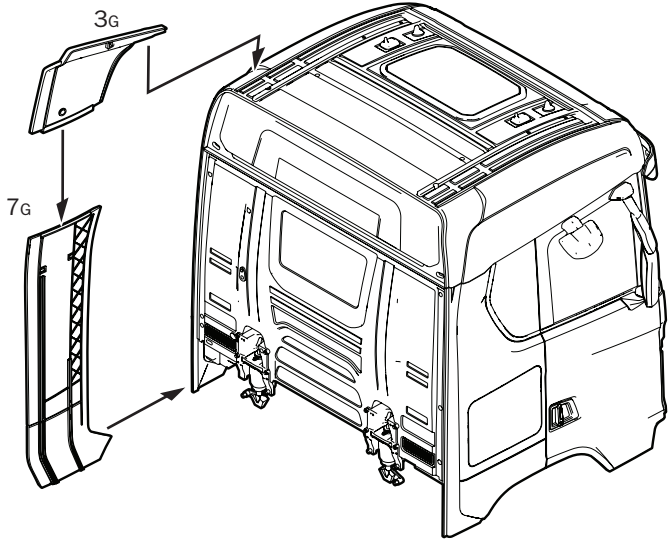

22

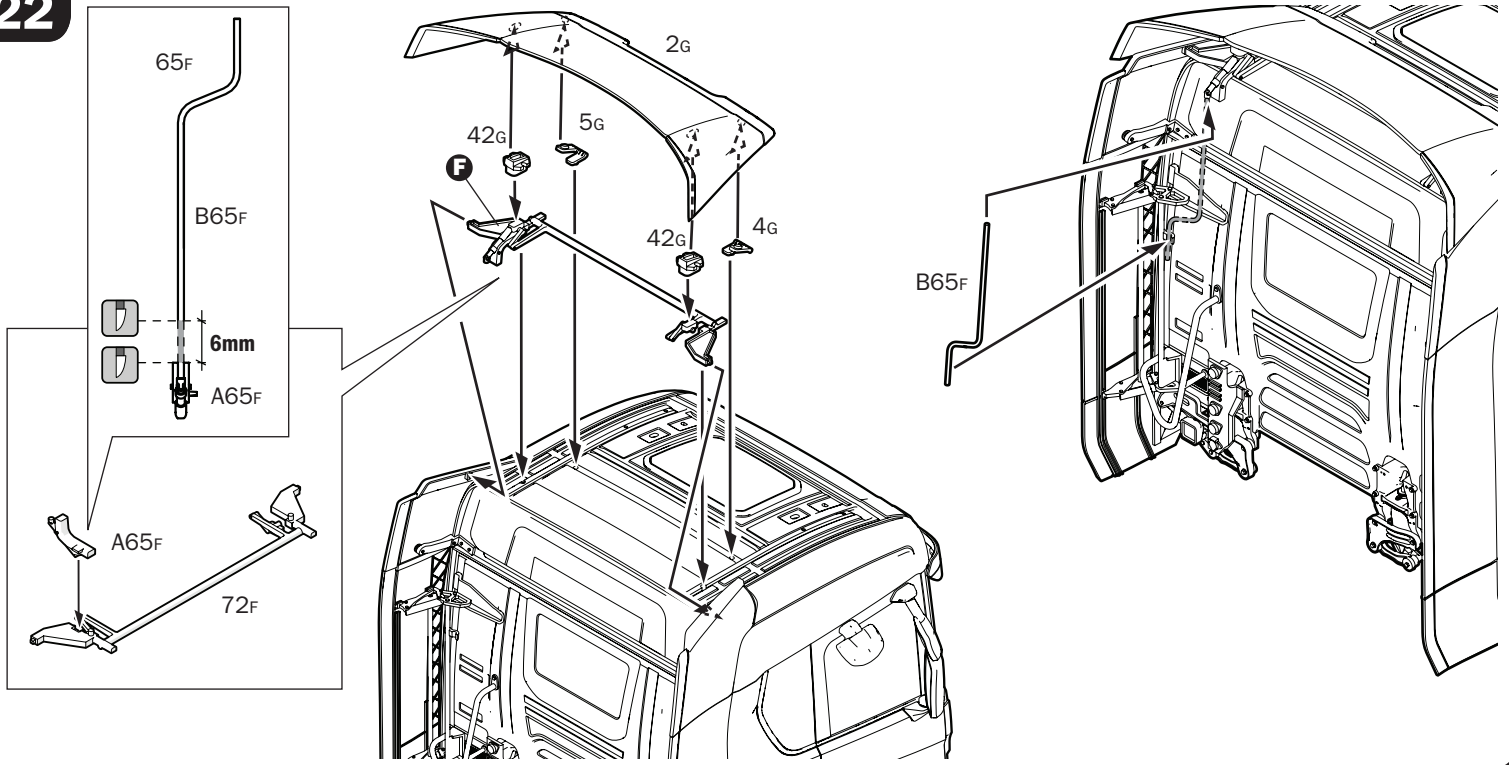

23

CLOSED VERSION

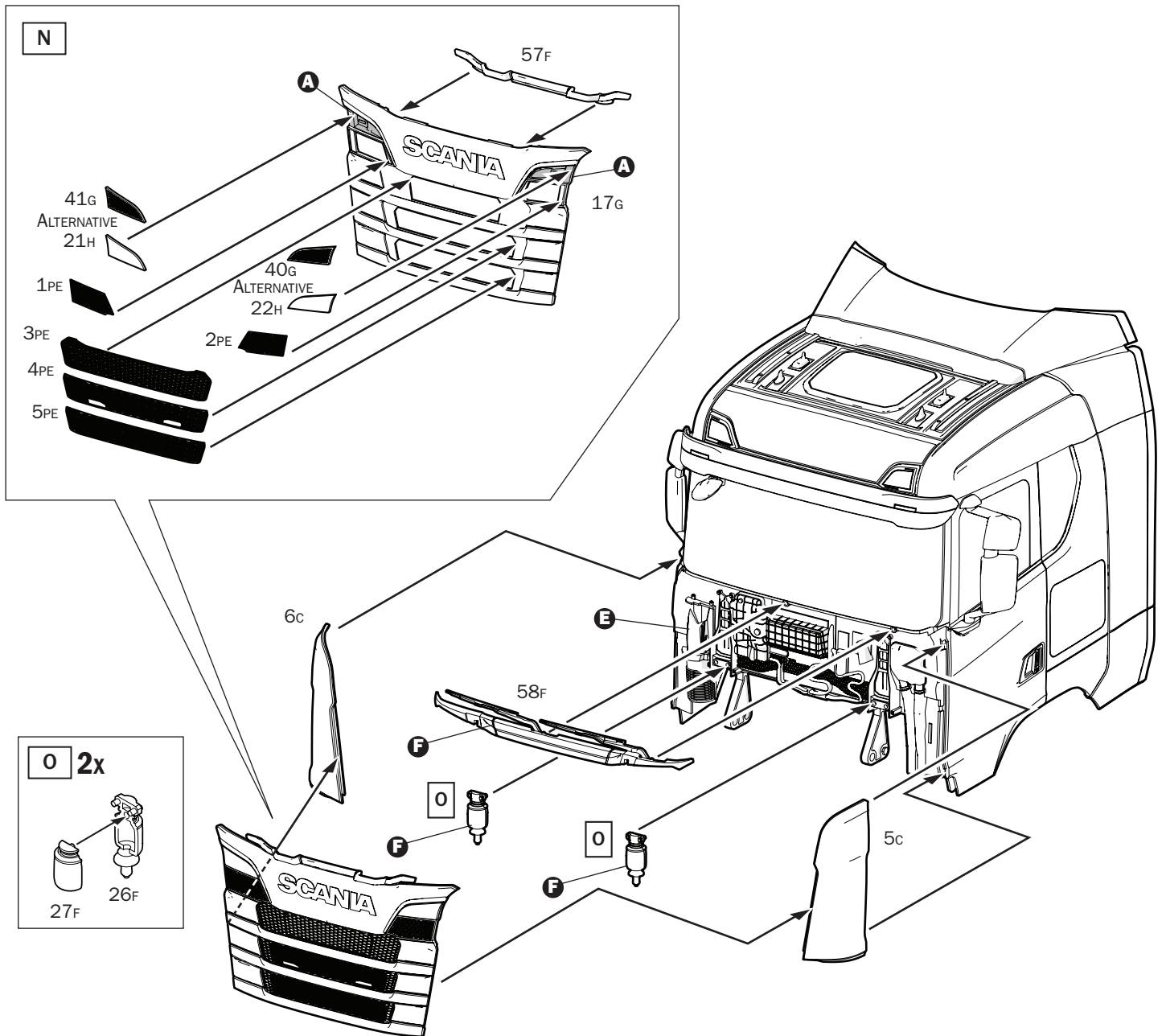

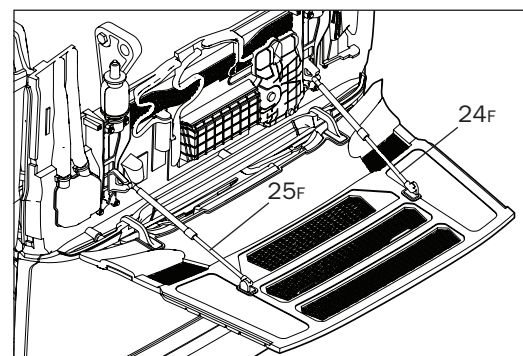
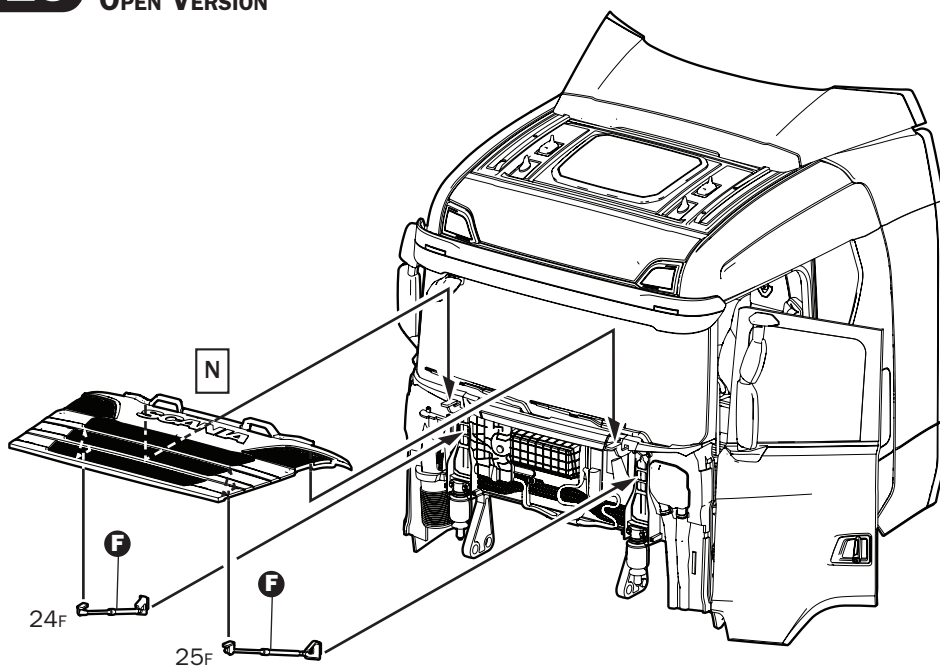
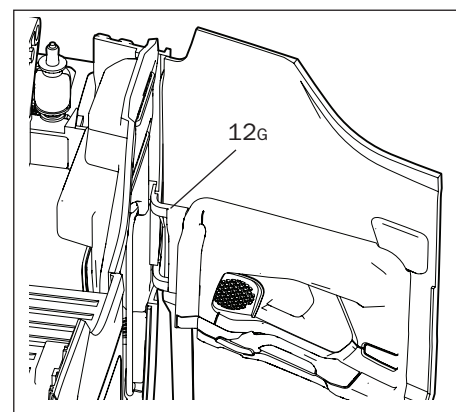
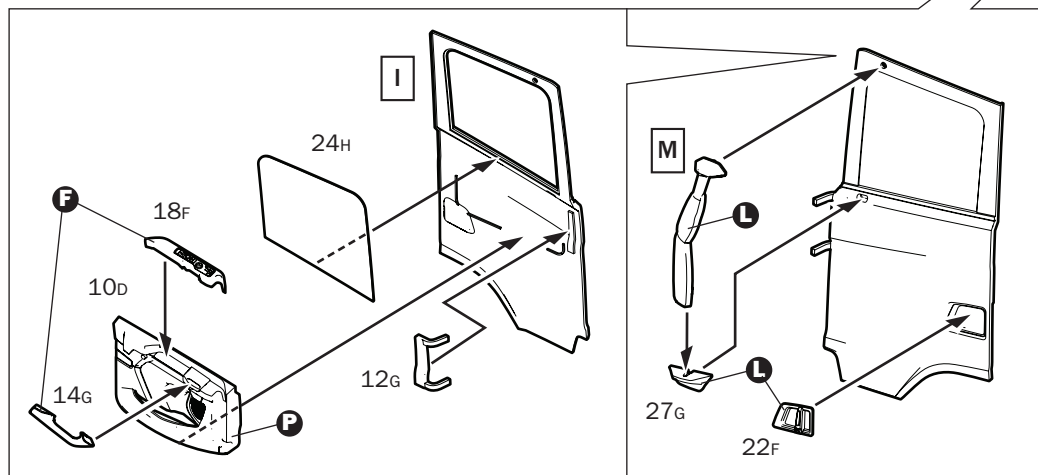
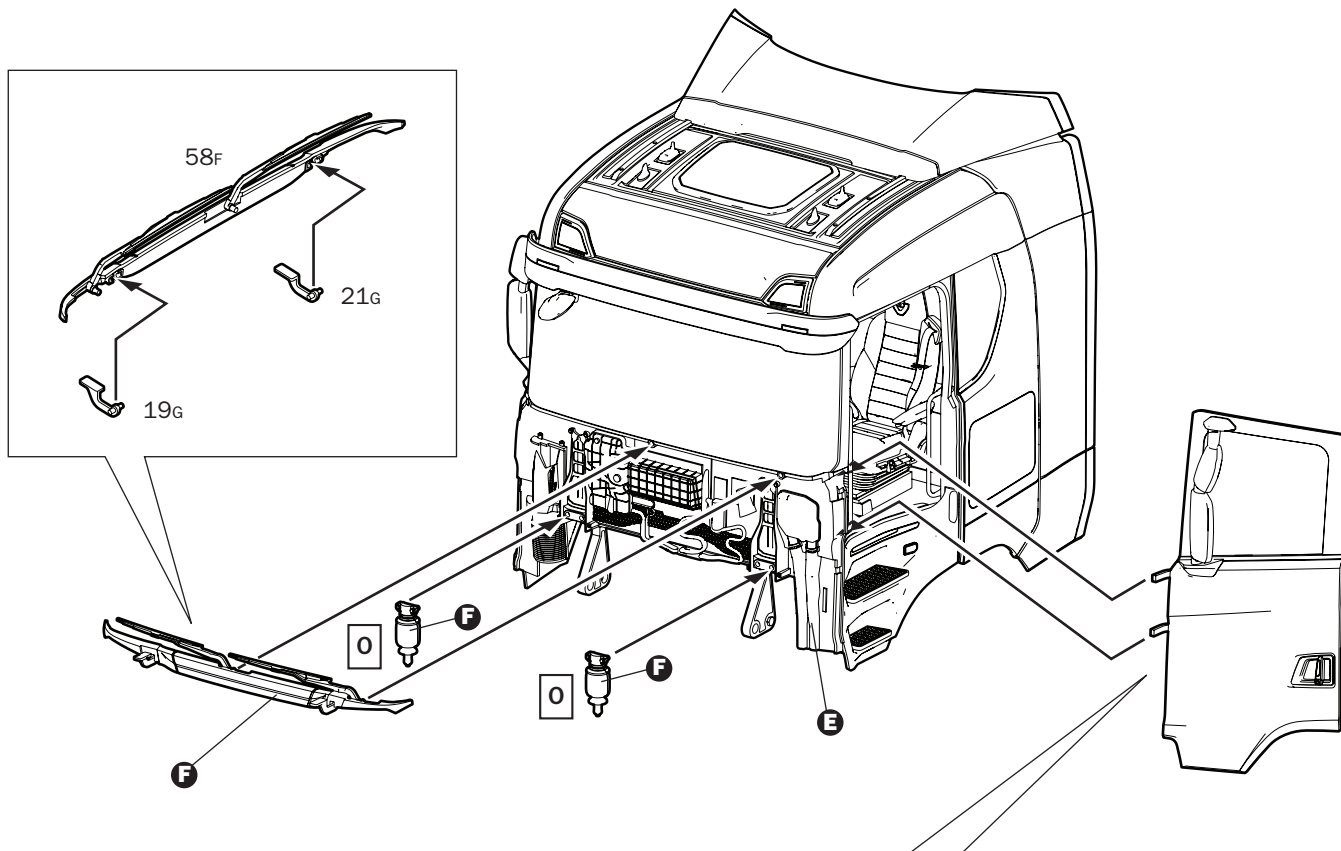

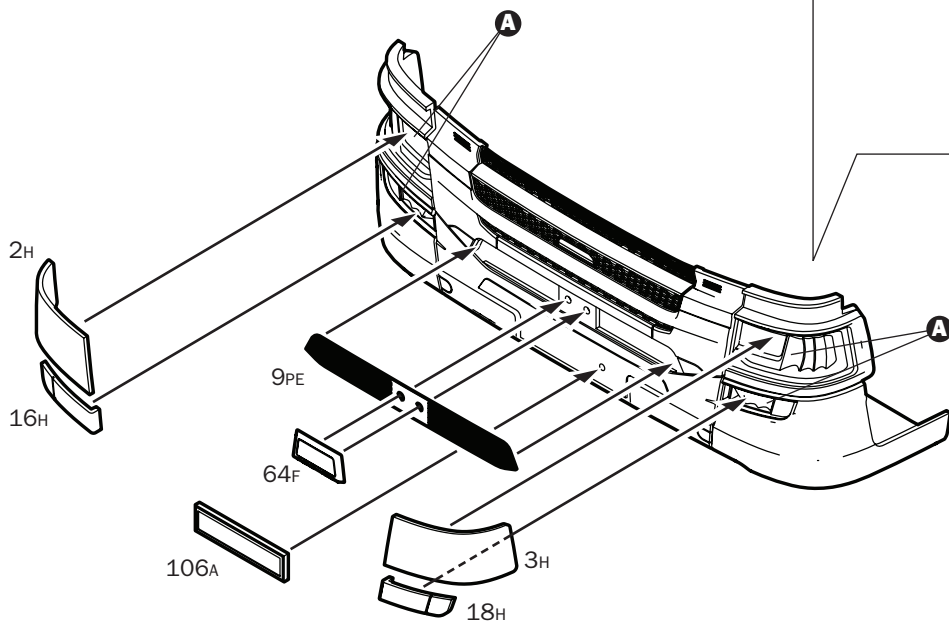
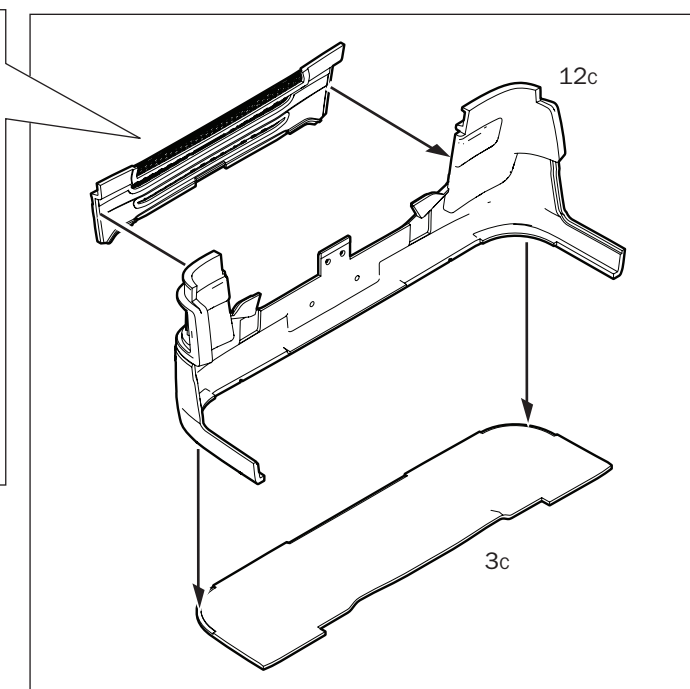
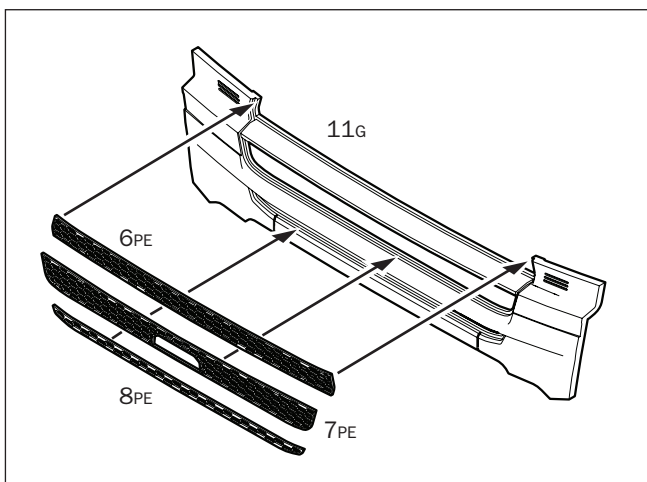
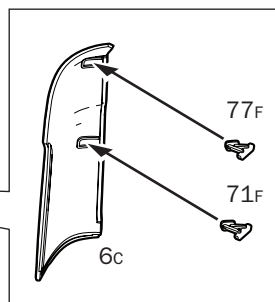
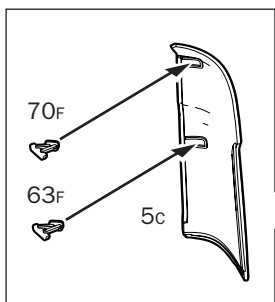
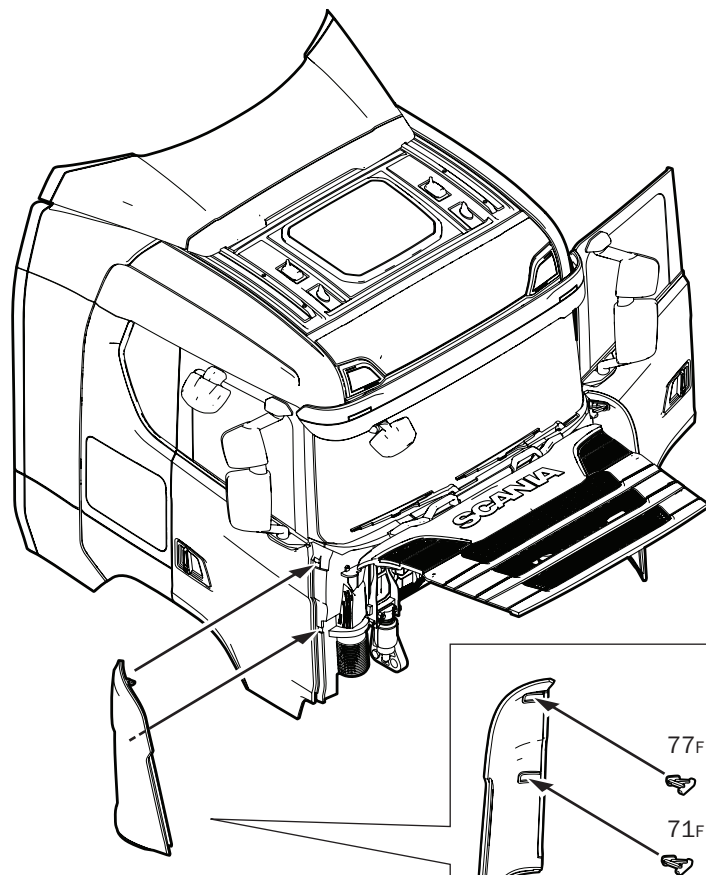
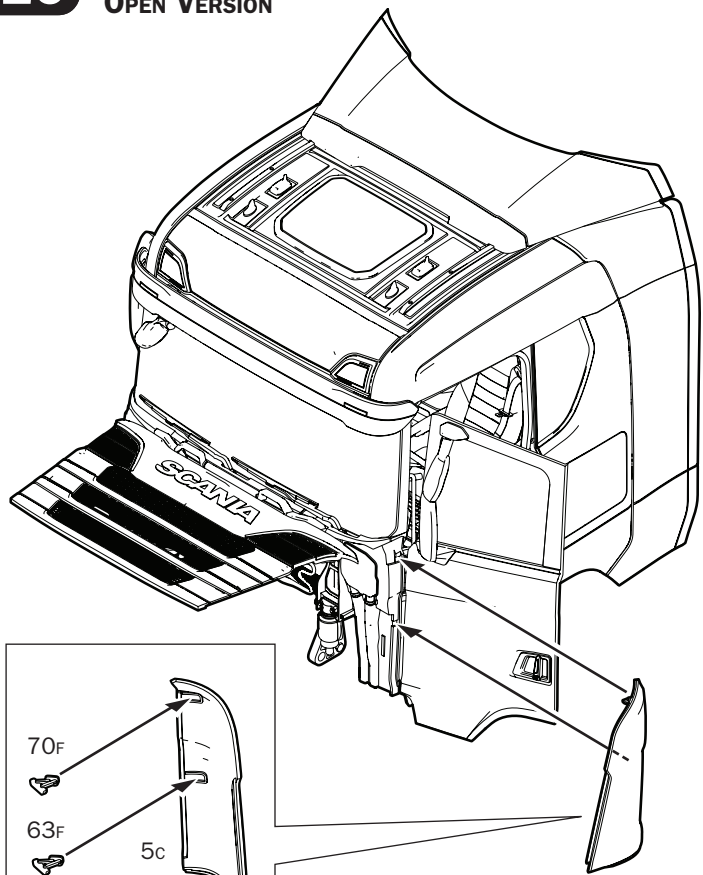

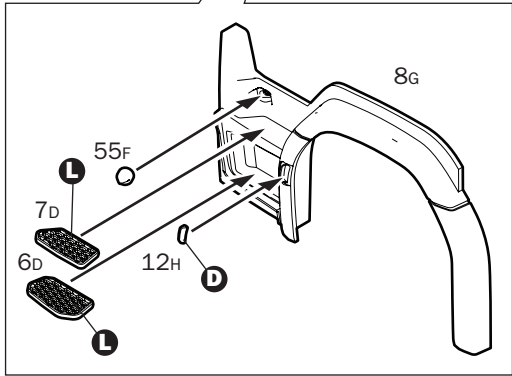
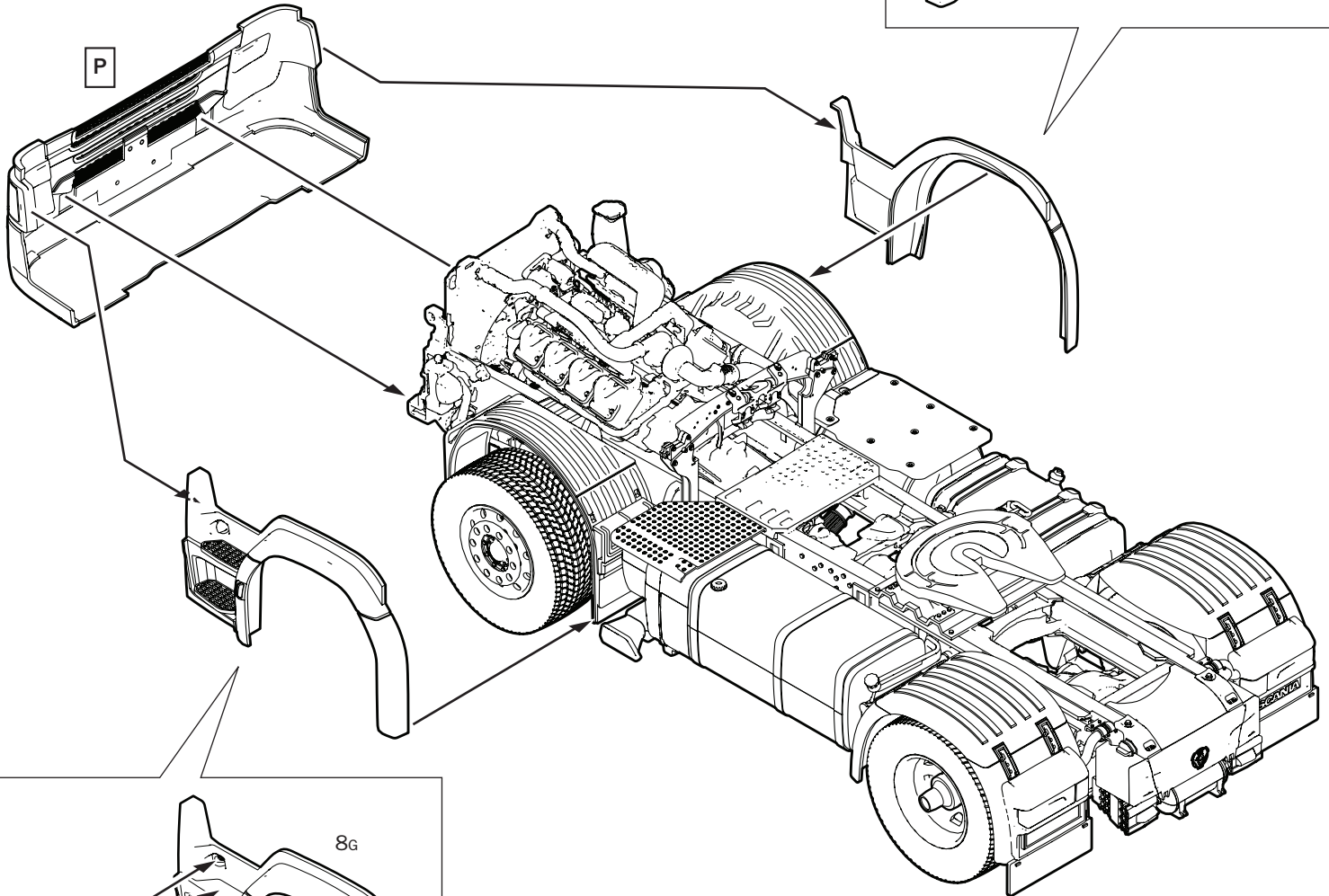

Q

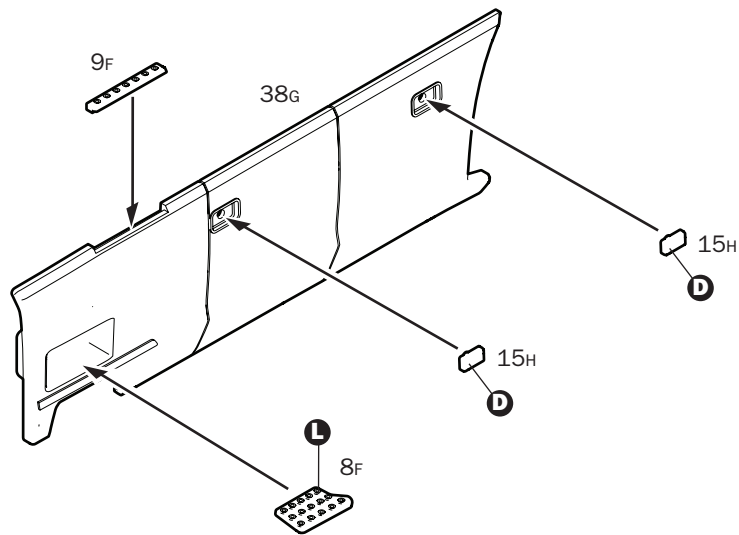

30

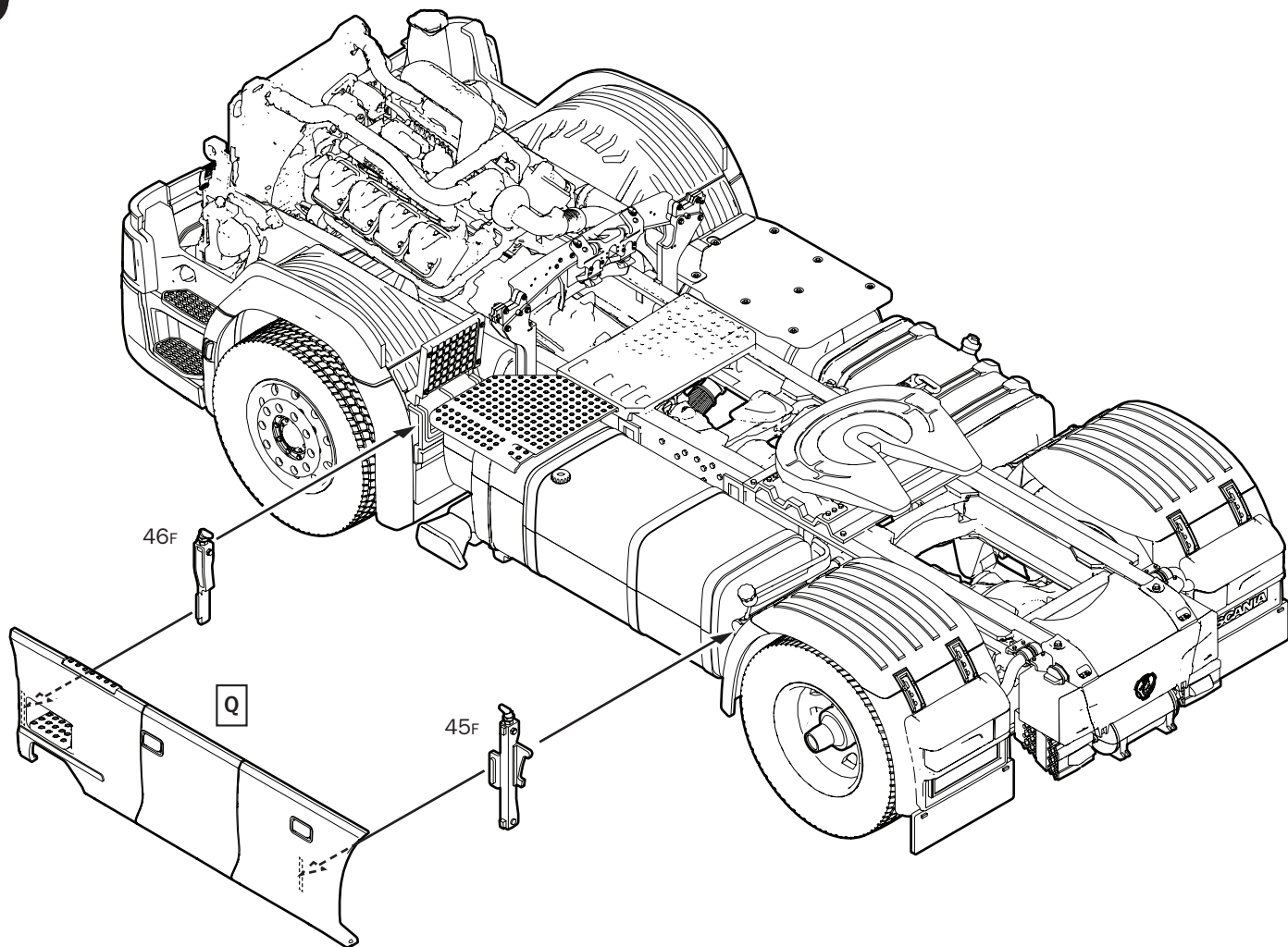

31

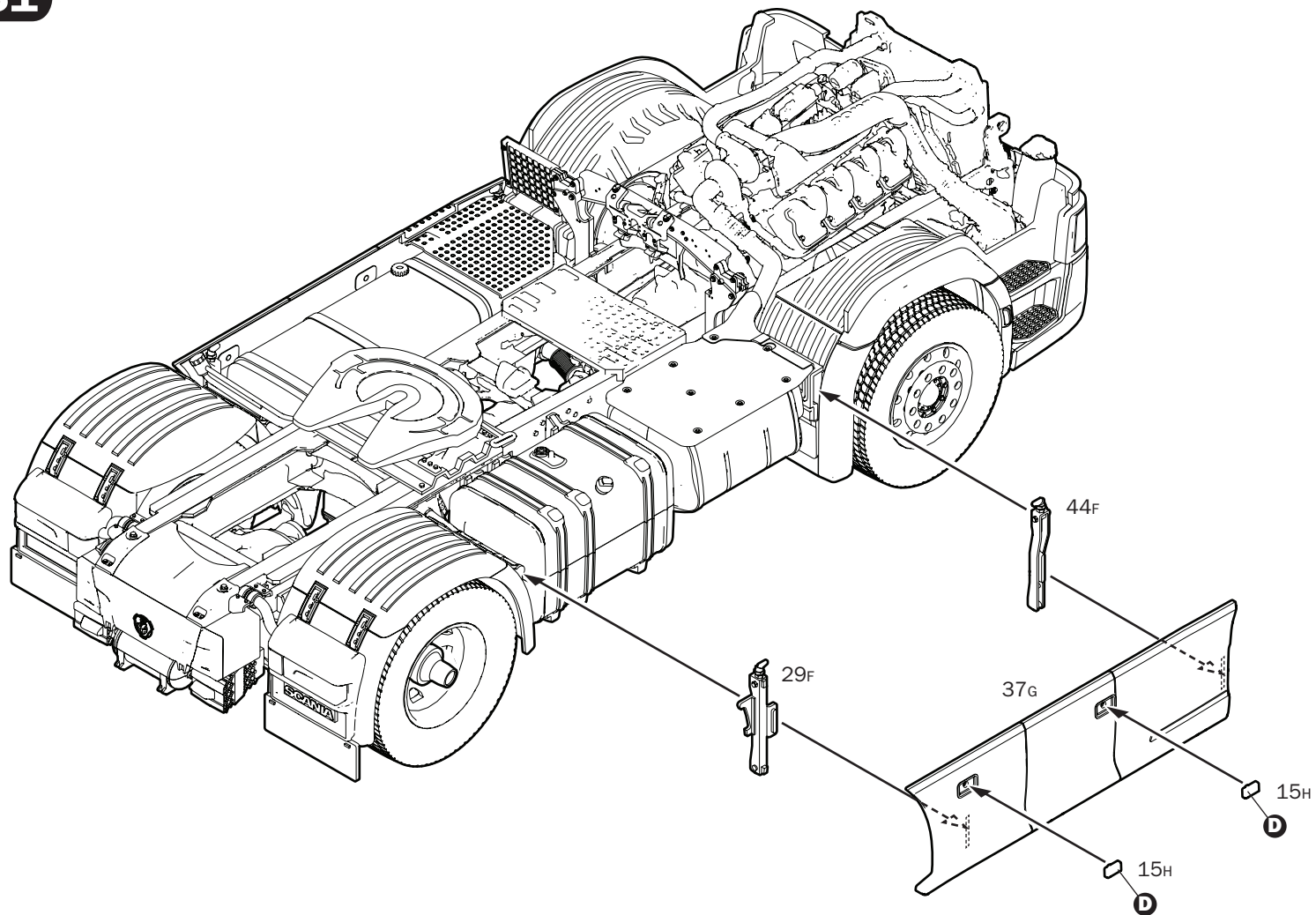

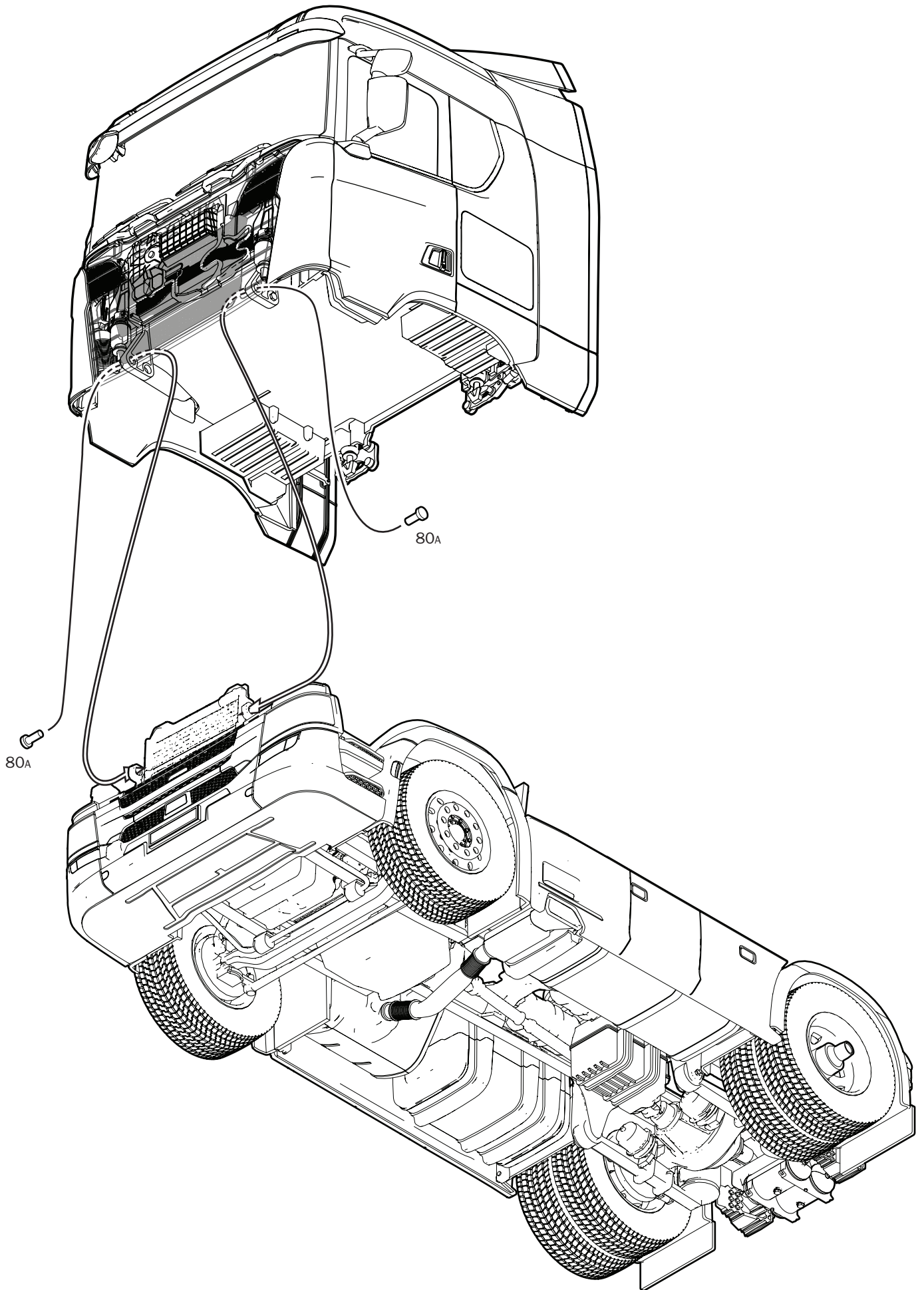

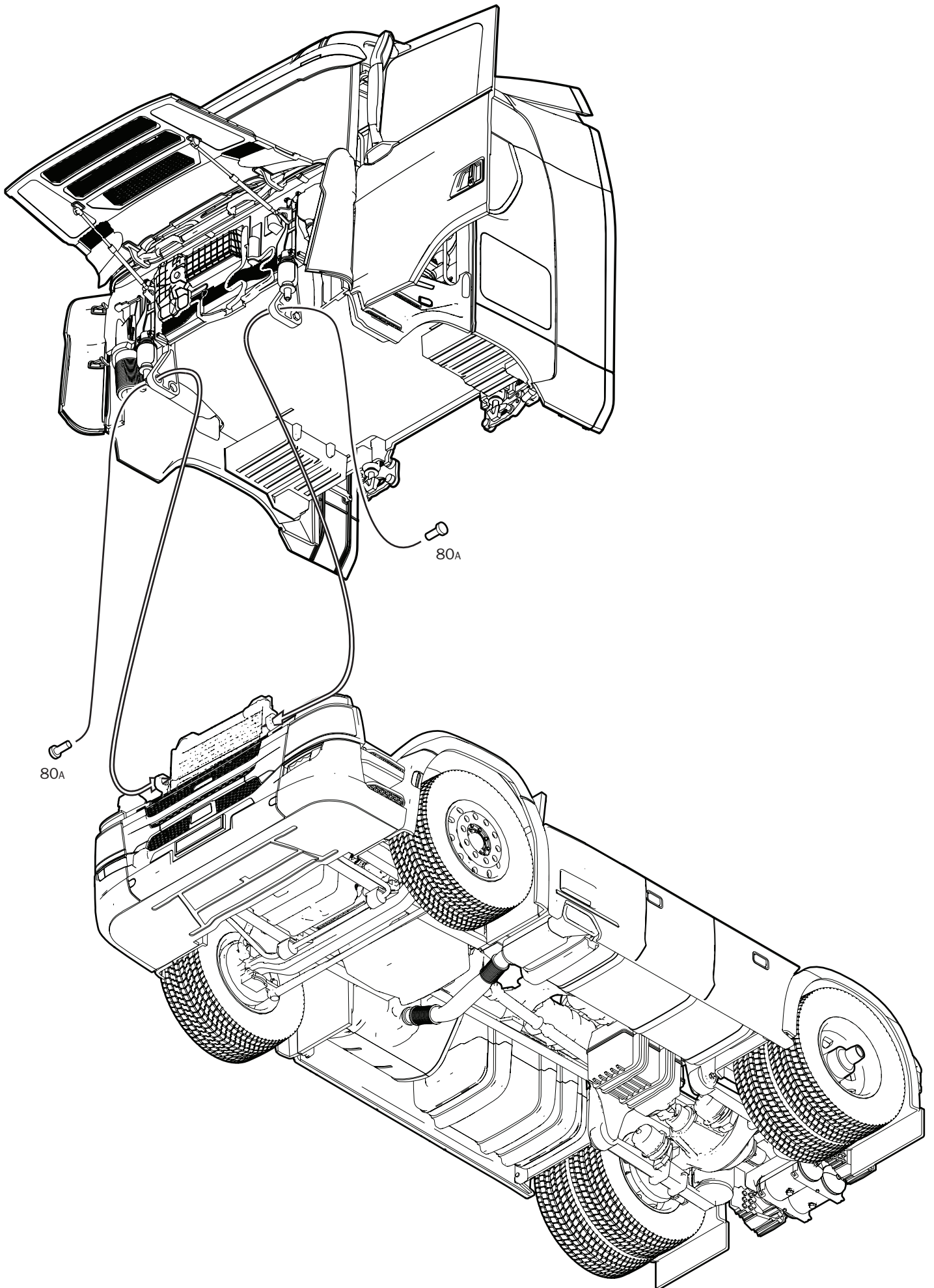



CLOSED VERSION

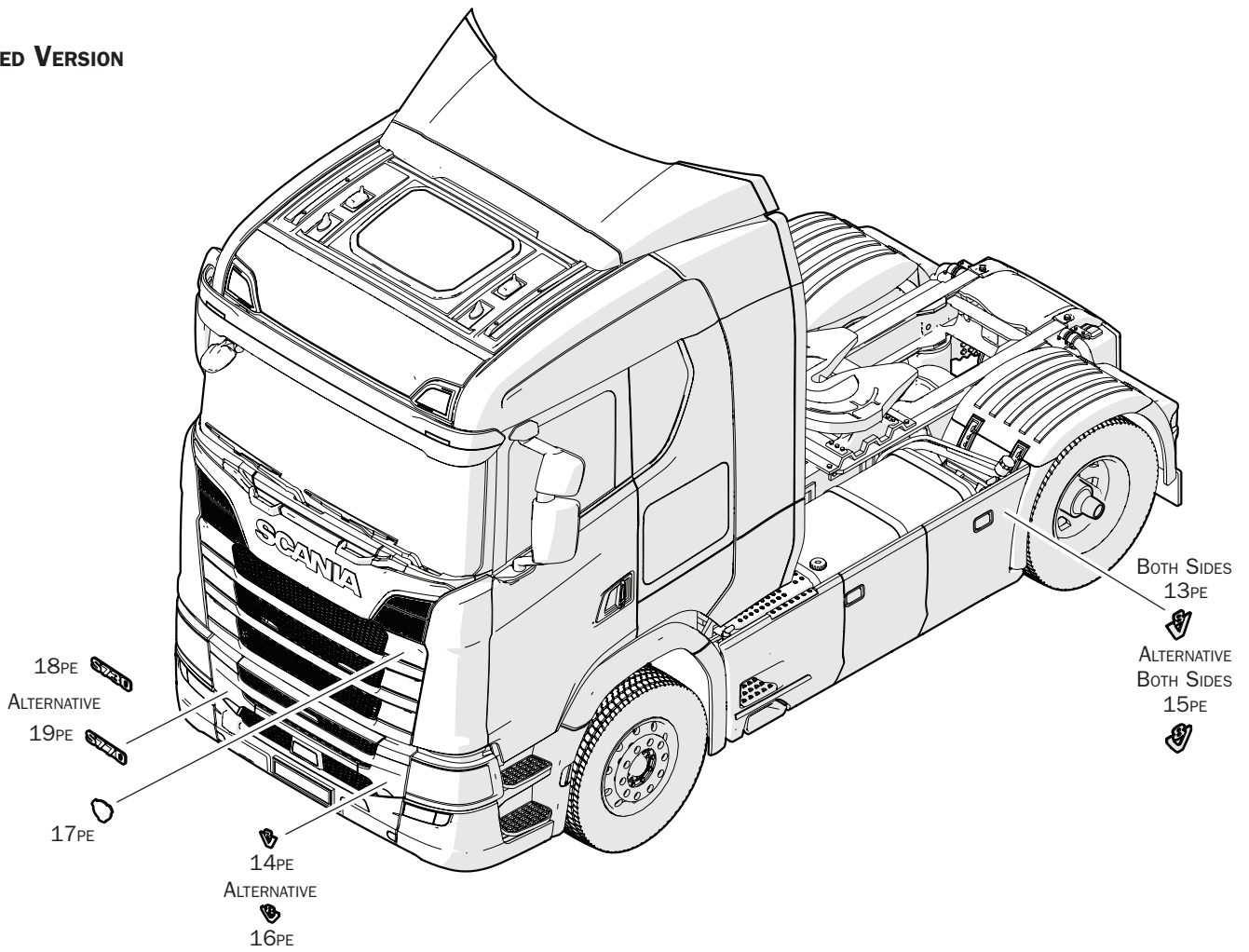

OPEN VERSION

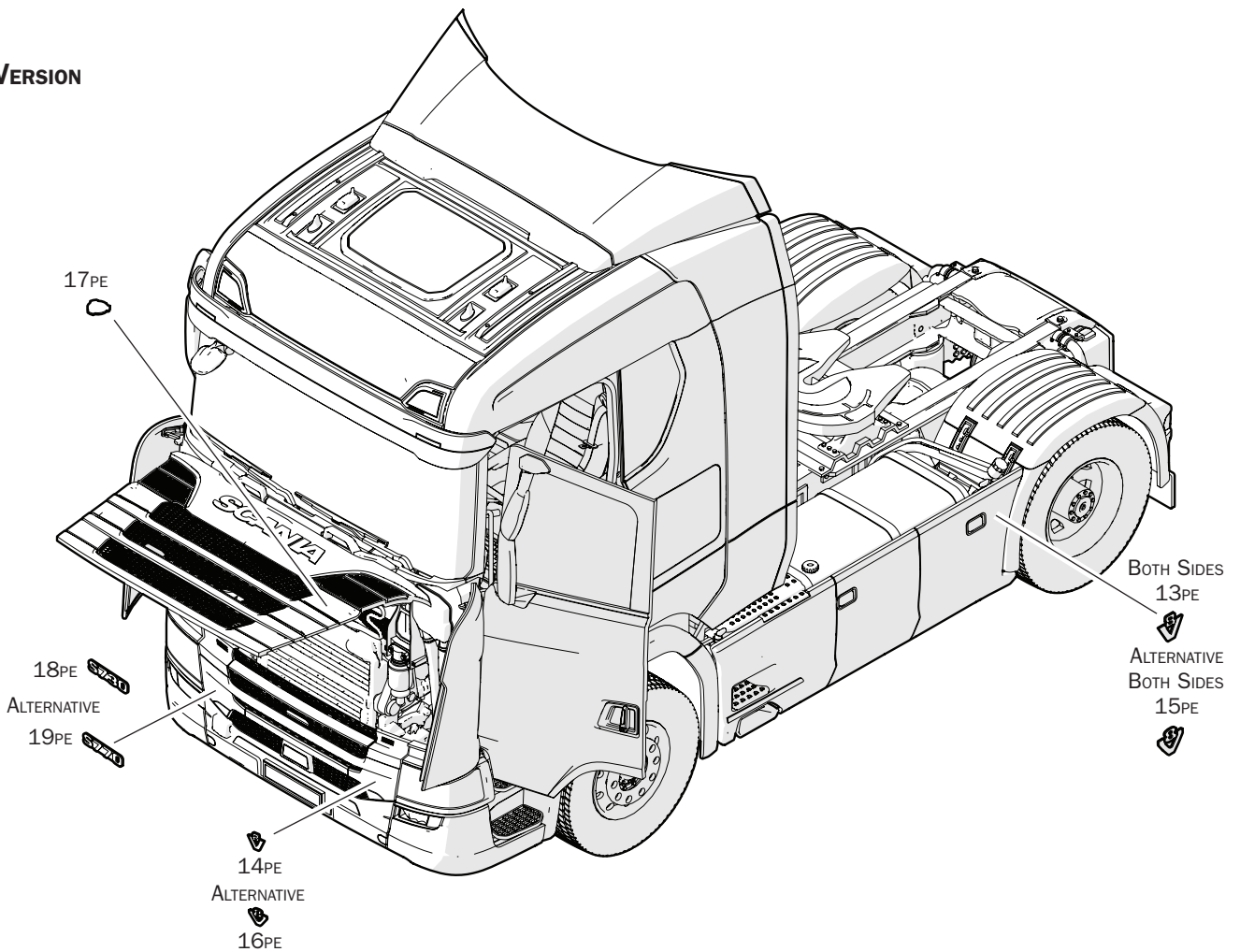

Istruzioni per l'applicazione delle decalcomanie. Ritagliare le decalcomanie occorrenti dal foglio, immergerle in un bicchiere di acqua pulita per circa 20", metterle in posizione sul modello e farle scivolare dalla carta: per una migliore aderenza comprimerle con una pezuola pulita.

Direction for applying the decals: cut the required decals out of the sheet; dip the into a glass of clean water for about 20"; position the decals on the kit, letting them slide from the paper. For a better adesion, press them by means of a clean rag.

Påläggning av decaler: klipp ut den decal som skall användas och doppa den i ett glas vatten under en 20". Sätt decalen på plats på modellen och låt den sakta glida av pappret. För att den skall sitta ordentligt, tryck till med en torr duk.



Anweisungen für Abziehbilder-Anbringung: Die benötigten Abziehbilder vom Blatt abscheiden, in ein Glas reines Wasser für etwa 20" eintauchen, auf das Modell legen und dann vom Papierbogen abnehmen. Um eine bessere Haftung zu erzielen, die Abziehbilder mit einem reinen Tuch andrücken.

Instruction pour l'application des décalcomanies: Couper les décalcomanies choisies et les plonger environ 20" dans un peu d'eau propre. Les placer sur le modèle en les faisant glisser de leur feuille et presser avec un morceau de chiffon pour éliminer les bulles d'air.

Istrucciones Para la aplicación de las calcomanías: cortar las requeridas, sumergirlas en un recipiente de agua limpia durante 20", colocar las calcomanías sobre el modelo, haciéndolas deslizar sobre el papel. Para una mejor adherencia, presionarlas con un trapito limpio.

Transfers: knip het benodigde deel uit, dempel et ca. 20" onder water, oud het transfer tegen het model en schuif het vanaf het papier op zijn plaats. Met een schoon doekje aandrukken.

アールー用取組書 説明書... それぞれのパーツの取り付け方は必ず説明書(20頁)を参照して、おこなってください。マーカーを押し出すようにしておこなってください。塗装の位置は必ずご確認ください。やわらかな布でマーカーを押して気泡を除去してください。マーカーは、おこなった後必ず取り除いてください。

Указания по применению декалей: Отделите нужную вам часть декалей от общего листа, погрузите ее на 20" минуты в чистую воду, затем, выбрав необходимое место на модели, переведите ту часть изображения, сдвинув его с бумажной основы. Для лучшего прилегания прокачайте декаль чистой тряпочкой.

## SCANIA S770 4x2 NORMAL ROOF

**PEARL LIGHT BLUE**  
TAMIYA TS-58

**GLOSS BLACK**  
TAMIYA X-1  
ITALERI 4695AP

**GUN METAL**  
TAMIYA X-10  
ITALERI 4691AP

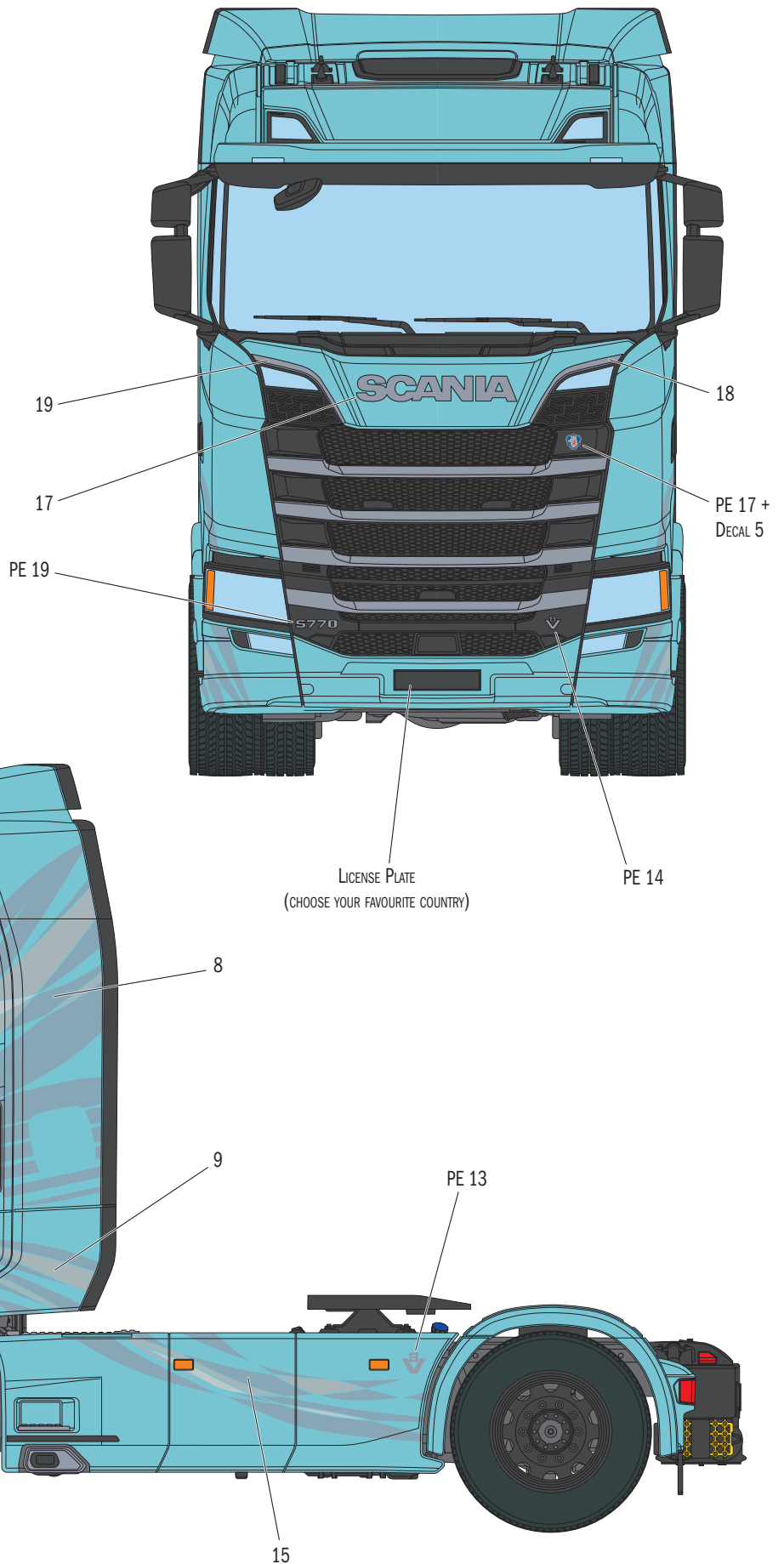

24

19

17

PE 19

LICENSE PLATE  
(CHOOSE YOUR FAVOURITE COUNTRY)

PE 14

PE 17 +  
DECAL 5

8

9

PE 13

10

7

15

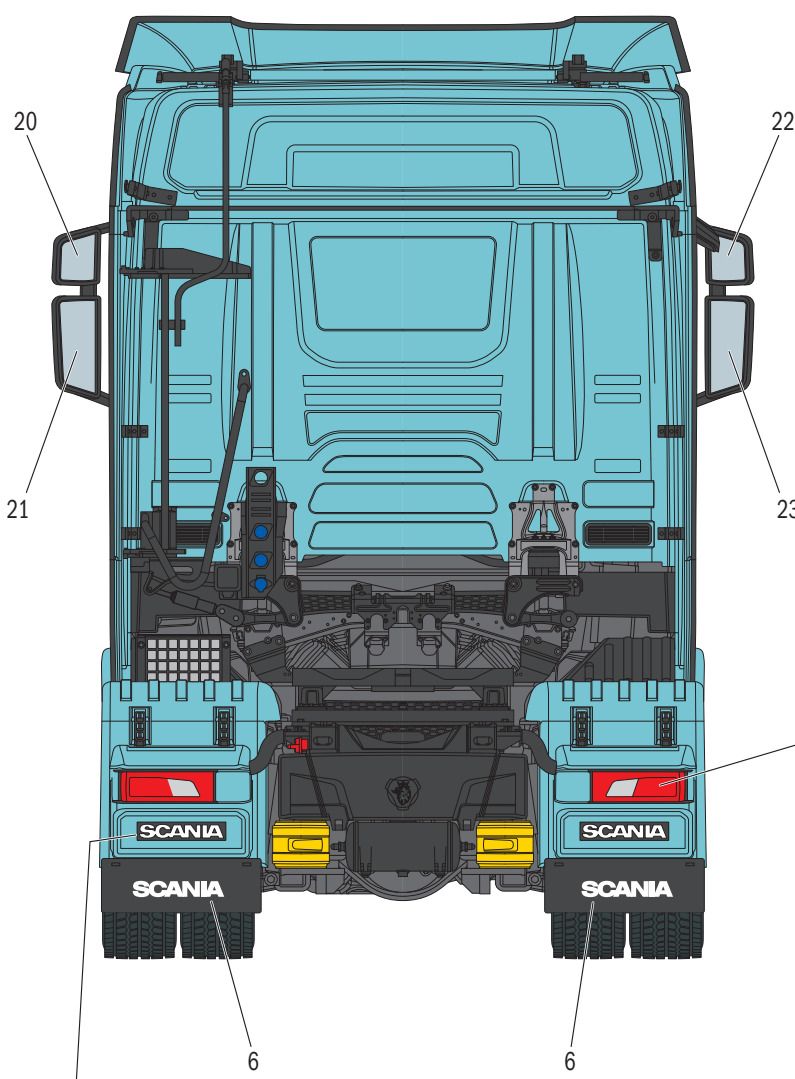

LICENSE PLATE  
(CHOOSE YOUR FAVOURITE COUNTRY)

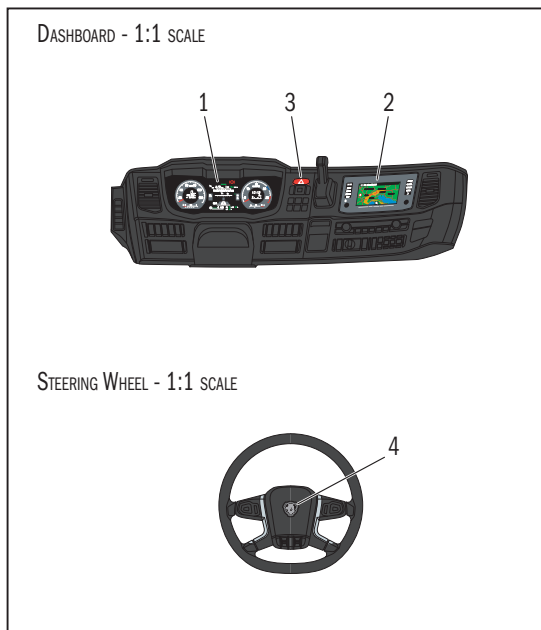

 CLEAR RED  
TAMIYA X-27

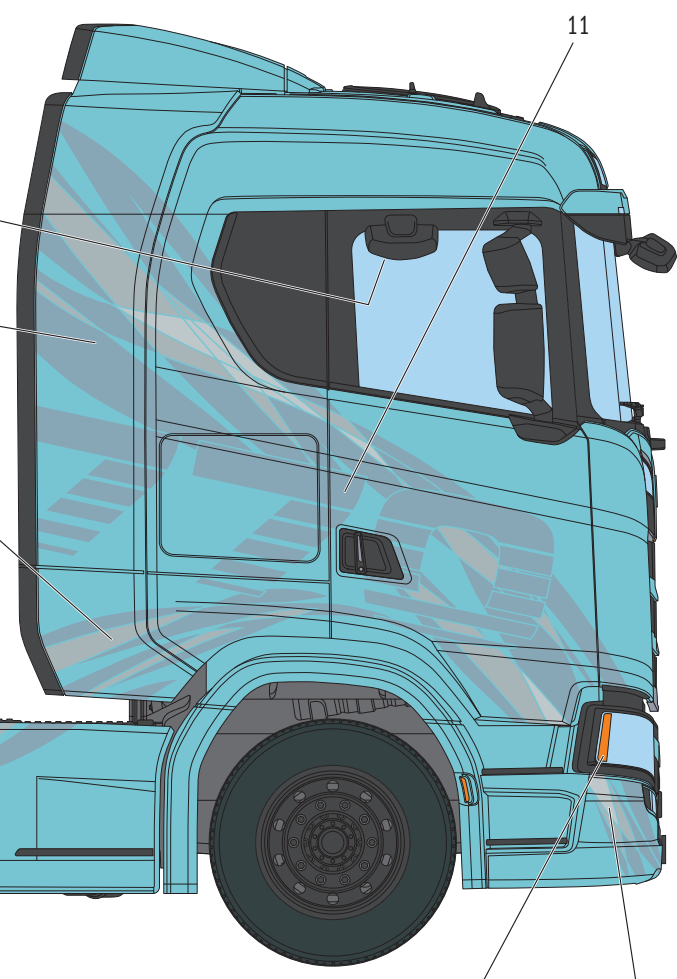

PE 13  CLEAR ORANGE  
TAMIYA X-26

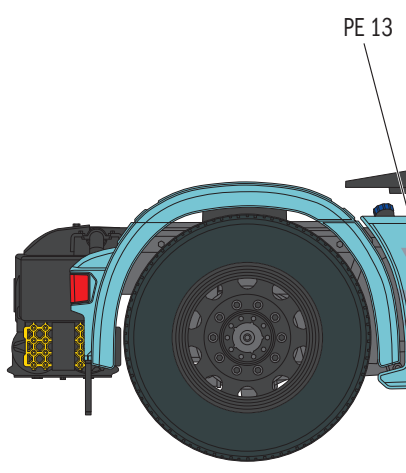

 CLEAR ORANGE  
TAMIYA X-26



**KIT No 3961 Scale 1:24 - Scania S770 4x2 Normal Roof**

NAME  
NOME  
NAME  
NOM  
NOMBRE  
NAAM

\_\_\_\_\_

**CONTACT OUR COSTUMER SERVICE ON [WWW.ITALERI.COM](http://WWW.ITALERI.COM)**

COUNTRY  
NAZIONE  
LAND  
PAYS  
PAIS  
LAND

\_\_\_\_\_

DATE OF BIRTH  
DATA DI NASCITA  
GEBURTSDATUM  
DATE DE NAISSANCE  
NACIDO/A EL  
GEBORTE DATUM

\_\_\_\_\_

**E-MAIL (\*required)** \_\_\_\_\_

DEFECTIVE PARTS  
PARTI DIFETTOSE  
DEFEKTE TEILE  
PIECES DEFECTUEUSES  
PIEZAS DEFECTUOSAS  
DEFECTE ONDERDELEN

PLACE OF PURCHASE  
ACQUISTATO PRESSO  
ORT DES KAUFES  
LIEU D'ACHAT  
LUGAR DE COMPRA  
PLAATS VAN AANKOOP

- |  |  |
|--|--|
| <input type="checkbox"/> Retail Store<br>Negozio<br>Einzelhandel<br>Detaillant<br>Detailista<br>Detailhandel | <input type="checkbox"/> Hyper Market<br>Grande Magazzino<br>Andere<br>Grande Surface<br>Gran Almacen<br>Hypermarket |
|--|--|

**ITALERI S.p.A.**  
Via Pradazzo, 6/B  
40012 - Calderara di Reno (BO) ITALY  
fax: 0039 51 726 459  
e-mail: [italeri@italeri.com](mailto:italeri@italeri.com)  
[www.italeri.com](http://www.italeri.com)