

Made in Italy

1:24 scale

No 3635

Willys Jeep MB 80th Anniversary 1941-2021

EN

In 1940, after World War II had broken out, the US general staff ordered various factories to design a light multi-purpose vehicle with all-wheel drive. The American Bantam Company, Willys Overland, and Ford Motor Co. competed with each other. Willys prototype was chosen, which, after an initial run of 1500 vehicles, went into mass production at the beginning of 1941 and reached a total output of 640.000 units out of which 277.000 pieces were produced by Ford under a licensing agreement. This shows that the Jeep was the most widely produced light vehicle of the war industry during World War II.

IT

Nel 1940, a conflitto mondiale già iniziato, lo Stato Maggiore degli Stati Uniti indisse un concorso per la costruzione di un veicolo leggero a quattro ruote motrici che servisse a numerosi impieghi. Alla gara parteciparono la American Bantam Company, la Willys Overland Motor e la Ford Motor Co. La scelta cadde sull'esemplare Willys, che, dopo una preserie di 1500 veicoli a partire dal 1941 fu messo sulle catene di montaggio e prodotto in ben 640.000 esemplari, di cui 277.000 su licenza della Ford. Questo fa sì che la "Jeep" sia stato il veicolo costruito nel maggior numero di esemplari dall'industria bellica durante il secondo conflitto mondiale.

DE

Im Jahr 1940, als der 2. Weltkrieg schon ausgebrochen war, schrieb der Generalstab der USA einen Wettbewerb zur Konstruktion eines leichten Fahrzeuges mit Allradantrieb aus, das zu verschiedensten Zwecken verwendet werden könnte. An dem Wettbewerb beteiligten sich American Bantam Company, Willys Overland Motor und Ford Motor Co. Die Wahl fiel auf das Modell Willys, das, nach einer Anfangsserie von 1500 Fahrzeugen, von Beginn des Jahres 1941 an, in 640.000 Einheiten auf Fließband produziert wurde, davon 277.000 in Lizenz bei Ford. Das zeigt, daß der Jeep das meistproduzierte Fahrzeug der Kriegswirtschaft des 2. Weltkriegs war.

FR

En 1940, après le début des hostilités, l'Etat-Major des Etats-Unis lança un concours pour la construction d'un véhicule léger à quatre roues motrices, susceptible d'être affecté à de nombreux usages. Ce concours vit la participation de l'American Bantam Company, de la Willys Overland Motor et de la Ford Motor Co. Le choix tomba sur l'exemplaire de Willys. A partir de 1941, après une première série de 1500 véhicules, celui-ci fut mis sur les chaînes des montage et fabriqué à 640.000 exemplaires, dont 277.000 sur licence Ford. Aussi la Jeep a-t-elle été le véhicule le plus fabriqué par l'industrie de guerre durant le second conflit mondial.

ES

En 1940, después de iniciada la Segunda Guerra Mundial, el Comando General de los EEUU ordenó a varias fábricas el diseño de un vehículo liviano de propósito múltiple con tracción total. La compañía American Bantam, Willys Overland y Ford Motor Co. compitieron entre ellos. El prototipo de Willys fue seleccionado, el cual, después de una producción inicial de 1500 vehículos, entro a producción en masa a comienzos de 1941 alcanzando un total de 640.000 unidades, de las cuales 277.000 fueron producidas por Ford bajo licencia. Esto demuestra que el Jeep fue el vehículo ligero de mayor producción por la industria de guerra durante la Segunda Guerra Mundial.

RU

Na het uitbreken van de 2e wereldoorlog in 1940 gaf de Amerikaanse Generale Staf opdracht aan de American Bantam Company, Willys Overland en de Ford Motor Company om een licht, 4-wiel aangedreven voertuig te ontwikkelen dat voor meerdere taken geschikt was. Het prototype van Willys werd uitgekozen en, na een aanvangsproductie van 1500 voertuigen, startte de massaproductie in het begin van 1941. In totaal werden er 640.000 stuks van gemaakt, waarvan 277.000 in licentie door Ford. Hiermee werd de Jeep het meest geproduceerde lichte voertuig van de 2e wereldoorlog.



- EN** **WARNING:** Model for adult collector age 14 and over
IT **ATTENZIONE:** Modello per collezionisti adulti di età superiore ai 14 anni
FR **ATTENTION:** Modèle pour modélistes de 14 and et plus.
DE **ACHTUNG:** Modellbausätze Für Modellbauer über 14 Jahre.
NL **WAARSCHWING:** Geschikt voor 14 jaar en ouder.
ES **ATENCION:** Modelo para modelistas mayores de 14 años.

EN ATTENTION - Useful advice!

STUDY THE INSTRUCTIONS CAREFULLY PRIOR TO ASSEMBLY. REMOVE PARTS FROM FRAME WITH A SHARP KNIFE OR A PAIR OF SCISSORS AND TRIM AWAY EXCESS PLASTIC. DO NOT PULL OUT PARTS. ASSEMBLE THE PARTS IN NUMERICAL SEQUENCE. USE PLASTIC CEMENT ONLY AND USE CEMENT SPARINGLY TO AVOID DAMAGING THE MODEL. BLACK ARROWS INDICATE PARTS TO BE GLUED TOGETHER. WHITE ARROWS INDICATE ON WHICH FRAME THE PARTS MUST BE ASSEMBLED WITHOUT USING CEMENT. THESE LETTERS (A - B - C...) INDICATE ON WHICH FRAME THE PARTS WILL BE FOUND. PAINT SMALL PARTS BEFORE DETACHING THEM FROM FRAME. REMOVE PAINT WHERE PARTS ARE TO BE CEMENTED. CROSSED OUT PARTS MUST NOT BE USED.

IT ATTENZIONE - Consigli utili!

PRIMA DI INIZIARE IL MONTAGGIO STUDIARE ATTENTAMENTE IL DISEGNO. STACCARE CON MOLTA CURA I PEZZI DALLE STAMPATE, USANDO UN TAGLIA-BALSA OPPURE UN PAIO DI FORBICI E TOGLIERE CON UNA PICCOLA LAMA O CON CARTA VETRO FINE EVENTUALI SBANATURE. MAI STACCARE I PEZZI CON LE MANI. MONTARLI SEGUENDO L'ORDINE DELLE NUMERAZIONI DELLE TAVOLE. ELIMINARE DALLA STAMPATA IL NUMERO DEL PEZZO APPENA MONTATO FACENDOCI SOPRA UNA CROCE. LE FRECCHE NERE INDICANO I PEZZI DA INCOLLARE. LE FRECCHE BIANCHE INDICANO I PEZZI DA MONTARE SENZA COLLA. USARE SOLO COLLA PER POLISTIROLO. LE LETTERE (A - B - C...) A LATI DEI NUMERI INDICANO LA STAMPATA OVE SI TROVA IL PEZZO DA MONTARE. I PEZZI SBARRATI DA UNA CROCE NON SONO DA UTILIZZARE.

DE ACHTUNG - Ein nützlicher Rat!

VOR DER MONTAGE DIE ZEICHNUNG AUFGEMERKSAM STUDIEREN. DIE EINZELNEN MONTAGETEILE MIT EINEM MESSER ODER EINER SCHERE VOM SPRITZUNG SORFÄHIG ENTFERNEN. EVENTUELLE GRATE WERDEN MIT EINER KLINGE ODER FEINEM SCHMIRGELPAPIER BESEITIGT. KEBENFALLS DIE MONTAGETEILE MIT DEN HÄNDEN ENTFERNEN. BEI DER MONTAGE DER TAFELNUMERIERUNG FOLGEN. PFEILE ZEIGEN DIE ZU KLEBENDEN TEILE WÄHREND DIE WEISSEN PFEILE DIE OHNE LEIM ZU MONTIERENDEN TEILE ANZEIGEN. BITTE NUR PLASTIKLEISTSTOFF VERWENDEN. DIE BUCHSTABEN (A - B - C...) NEBEN DEN NUMMERN ZEIGEN AUF WELCHEM SPRITZUNG DER ZU MONTIERENDE TEIL ZU FINDEN IST. DIE MIT EINEM KREUZ MARKIERTEN TEILE SIND NICHT ZU VERWENDEN.

FR ATTENTION - Conseils utiles!

AVANT DE COMMENCER LE MONTAGE, ETUDIER ATTENTIVEMENT LE DESSIN. DÉTACHER AVEC BEAUCOUP DE SOIN LES MORCEAUX DES MOULES EN USANT UN MASSICOT OU BIEN UN PAIR DE CISEAUX ET COUPER AVEC UNE PETITE LAME AVEC DE PAPIER DE VITRE FIN ÉBARBÉS ÉVENTUELS. MAIJS DÉTACHER LES MORCEAUX AVEC LE MAINS MONTER LES EN SUIVANT L'ORDRE DE LA NUMÉROTATION DES TABLES. ÉLIMINER DE LA MOULE LE NUMÉRO DE LA PIÈCE QUI VIENT D'ÊTRE MONTÉE. EN LE S'EFFRANT AVEC UNE CROIX. LES FLÈCHES NOIRES INDICENT LES PIÈCES À COLLER. LES FLÈCHES BLANCHES INDICENT LES PIÈCES À MONTER SANS COLLE. EMPLOYER SEULEMENT DE LA COLLE POUR POLYSTYROL. LES LETTRES (A - B - C...) AUX CÔTÉS DES NUMÉROS INDICENT LA MOULE OÙ SE TROUVE LA PIÈCES A MONTER. LES PIÈCES MARQUÉES PAR UNE CROIX NE SONT PAS À UTILISER.

ES ATENCION - Consejos útiles!

ESTUDAR LAS INSTRUCCIONES CUIDADOSAMENTE ANTES DE COMENZAR EL MONTAJE. SEPARAR LAS PIEZAS DE LAS BANDEJAS CON UN CUCHILLO AFILADO O UN PAR DE TUERAS Y RETIRAR EL EXCESO DE PLÁSTICO O REBADA. NO ARRANCAR LAS PIEZAS. MONTAR LAS PIEZAS EN ORDEN NUMÉRICO. UTILIZAR SOLAMENTE PEGAMENTO PARA PLÁSTICO Y EN POCAS CANTIDAD PARA EVITAR QUE SE DANIE EL MODELO. LAS FLECHAS NEGRAS INDICAN LAS PIEZAS QUE SE DEBEN PEGAR JUNTAS. LAS FLECHAS BLANCAS INDICAN LAS PIEZAS QUE DEBEN ENSAMBLARSE SIN USAR PEGAMENTO. LAS LETRAS (A - B - C...) INDICAN EN QUE BANDEJA SE ENCUENTRAN LAS PIEZAS. PINTAR LAS PIEZAS PEQUEÑAS ANTES DE SEPARARLAS DE LA BANDEJA. RETIRAR LA PINTURA DE LOS LUGARES POR DONDE SE DEBÁN PEGAR LAS PIEZAS.

RU ПРЕДУПРЕЖДЕНИЕ - важные!

ПЕРЕД ТЕМ КАК ПРИБЛИТИТЬ К СБОРКЕ, ВНИМАТЕЛЬНО ИЗУЧИТЬ ЧЕРТЕЖ. ОЧЕНЬ ОСТОРОЖНО ОТСОЕДИНИТЬ РАСПЕЧАТАННЫЕ ЭЛЕМЕНТЫ. ИСПОЛЬЗОВАТЬ ДЛЯ ЭТОГО КАЧЕСТВЕННЫЙ НОЖ ИЛИ ПАРУ НОЖИЦ, СНИТЬ НЕРОВНОСТИ С ПОМОЩЬЮ ТОНКОГО ЛЕЗВИЯ ИЛИ С ПОМОЩЬЮ АБРАЗИВНОЙ БУМАГИ. НЕ ОТСОЕДИНЯТЬ ЭЛЕМЕНТЫ РУКАМИ. ВЫПОЛНИТЬ СБОРКУ СОГЛАСНО ПОРЯДКУ НУМЕРАЦИИ ТАБЕЛИ. УДАЛИТЬ ИЗ СТИКА ТОЛЬКО ТО ЧТО СОБРАЛИ ДЕТАЛЬ. ПЕРЕЧЕРКОВАЯ ЕЕ. ЧЕРНЫЕ СТРЕЛКИ УКАЗЫВАЮТ ДЕТАЛИ ДЛЯ СБОРКИ. БЕЛЫЕ СТРЕЛКИ УКАЗЫВАЮТ ДЕТАЛИ, КОТОРЫЕ СОБИРАЮТСЯ БЕЗ КЛЕЯ. ИСПОЛЬЗОВАТЬ ТОЛЬКО КЛЕЙ ДЛЯ ПЕНОПЛАСТА. БУКВЫ (А - В - С...) НА ПРОНУМЕРОВАННЫХ СТОРОНАХ УКАЗЫВАЮТ МЕСТ, ГДЕ НАХОДИТСЯ ДЕТАЛЬ. ПЕРЕЧЕРКОВАННЫЕ ДЕТАЛИ НЕ ИСПОЛЬЗОВАТЬ.

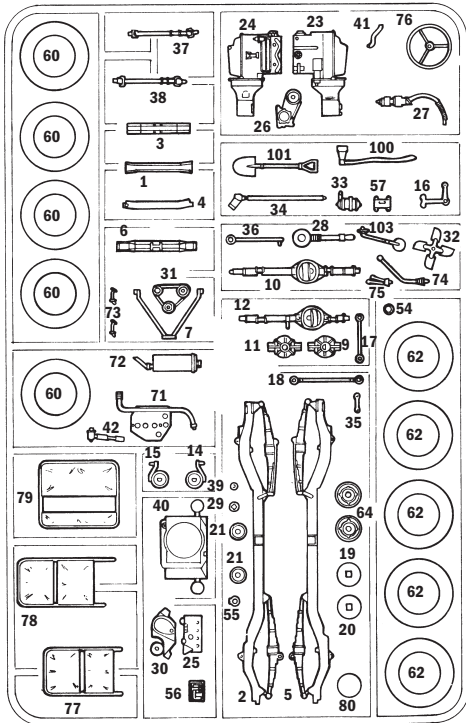
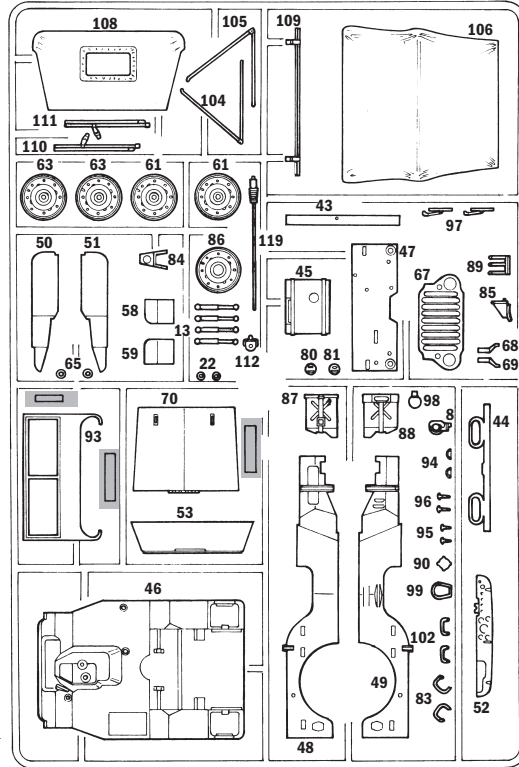
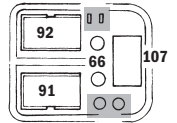
A**B****C****5x**

Ribadire a caldo
Rivet hot
River à chaud
Warm ennieten

A**METAL GLOSS SILVER**

F.S. 17178

ITALERI ACRYLICPAINT - 4678AP

E**GLOSS RED**

F.S. 11302

ITALERI ACRYLICPAINT - 4605AP

B**FLAT FIELD GREEN**

F.S. 34097

ITALERI ACRYLICPAINT - 4708AP

F**FLAT METAL STEEL**

F.S. 37178

ITALERI ACRYLICPAINT - 4679AP

C**FLAT BLACK**

F.S. 37038

ITALERI ACRYLICPAINT - 4768AP

G**GLOSS ORANGE**

F.S. 12197

ITALERI ACRYLICPAINT - 4682AP

D**FLAT OLIVE DRAB**

F.S. 34088

ITALERI ACRYLICPAINT - 4315AP

H**FLAT RUST**

F.S. 30109

ITALERI ACRYLICPAINT - 4675AP

CHOOSE VERSION BEFORE ASSEMBLY

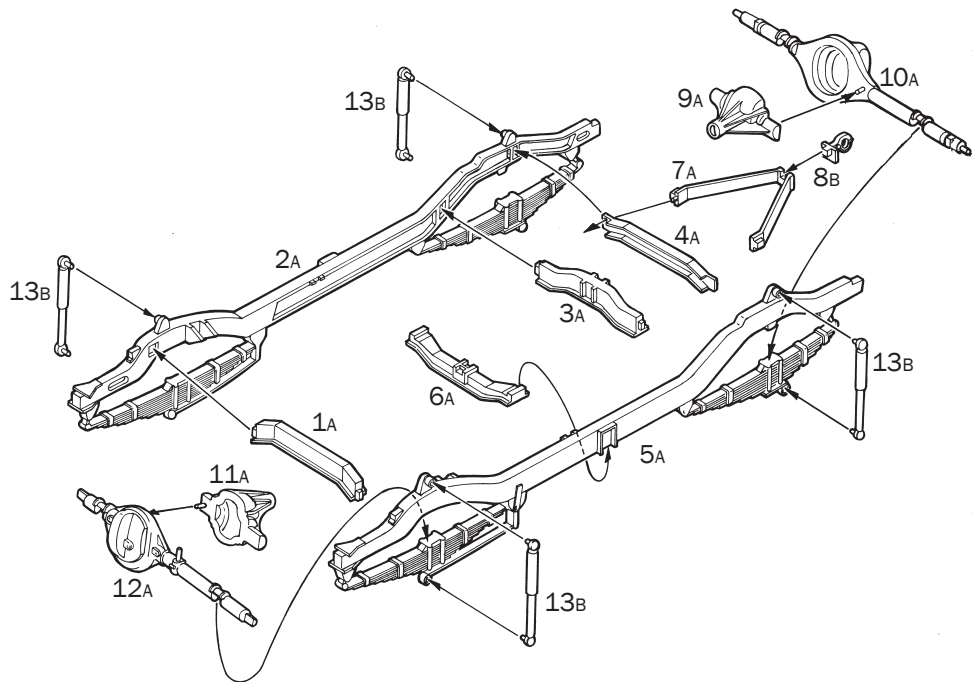
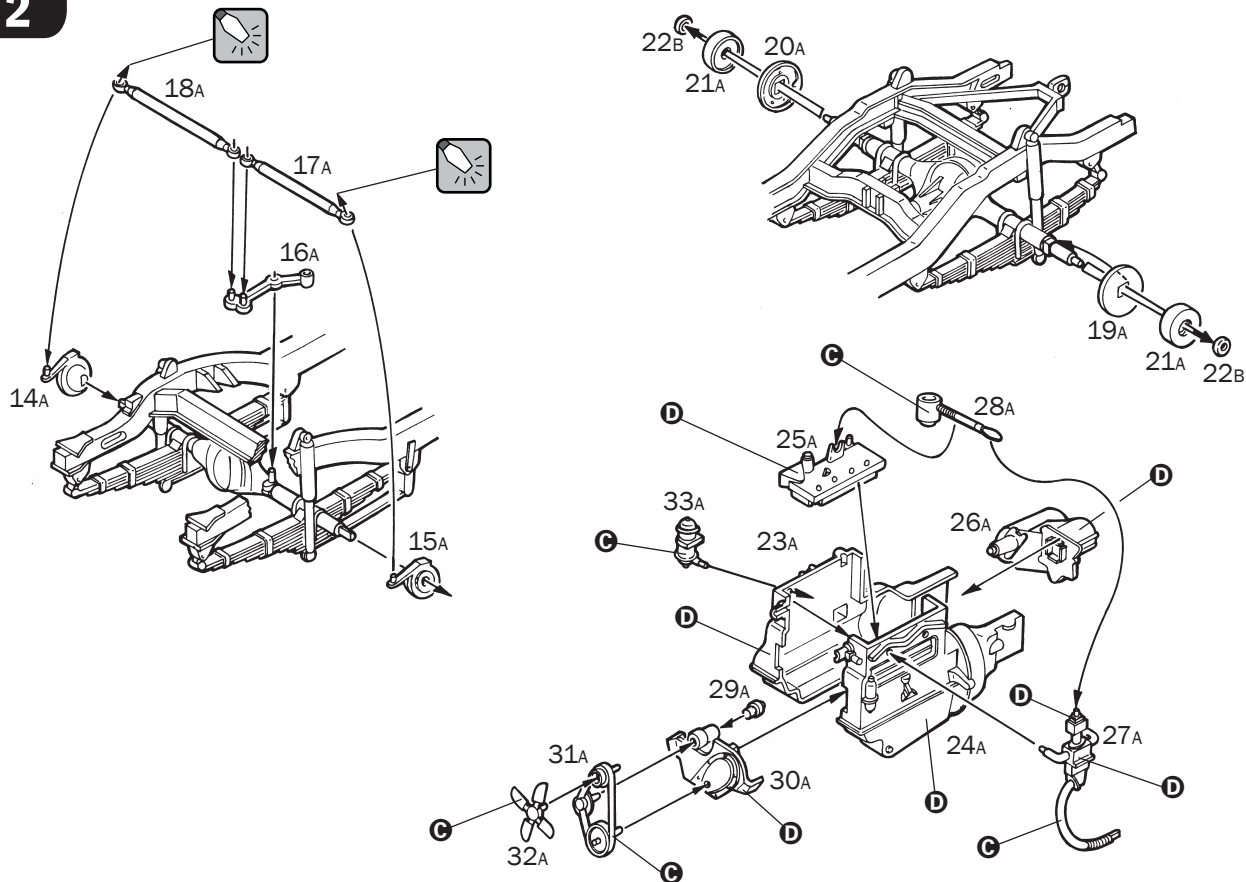
1**2**

5

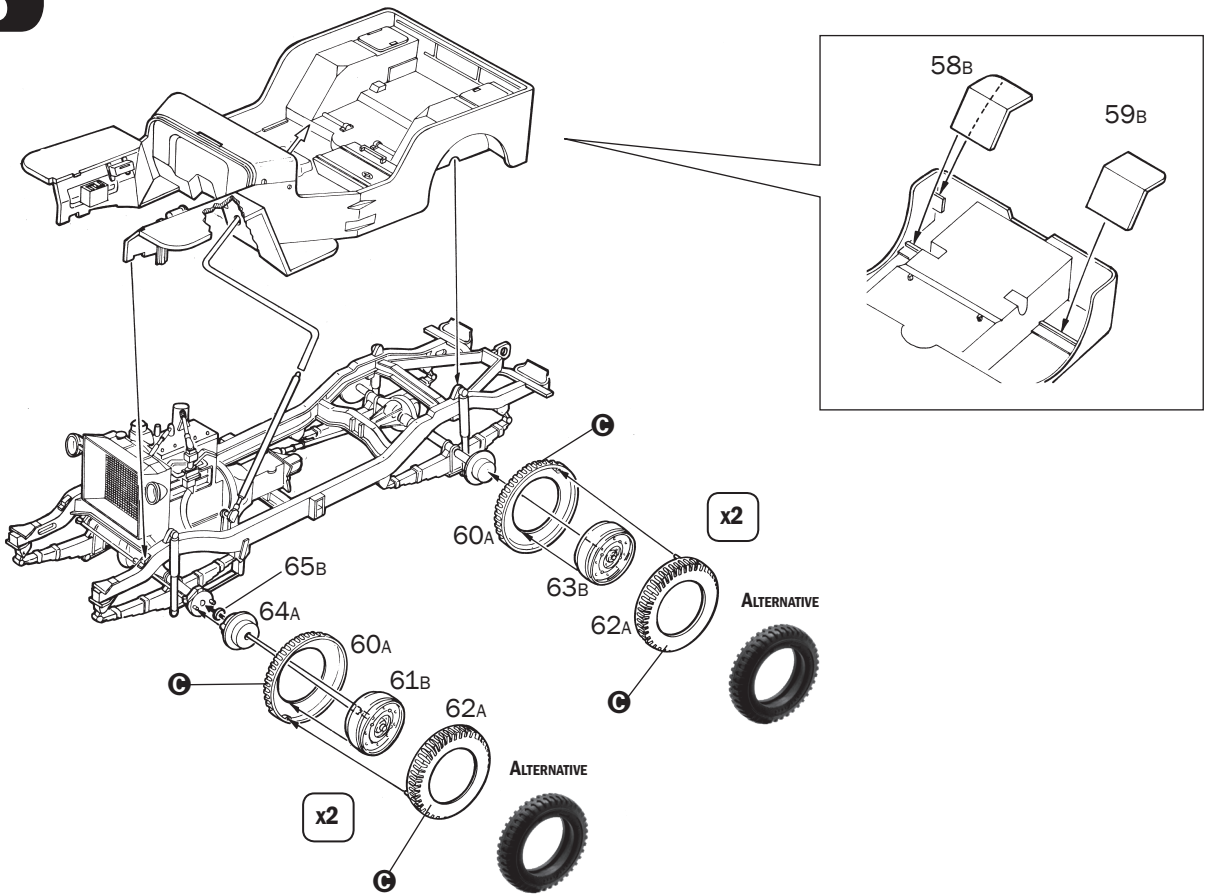

6

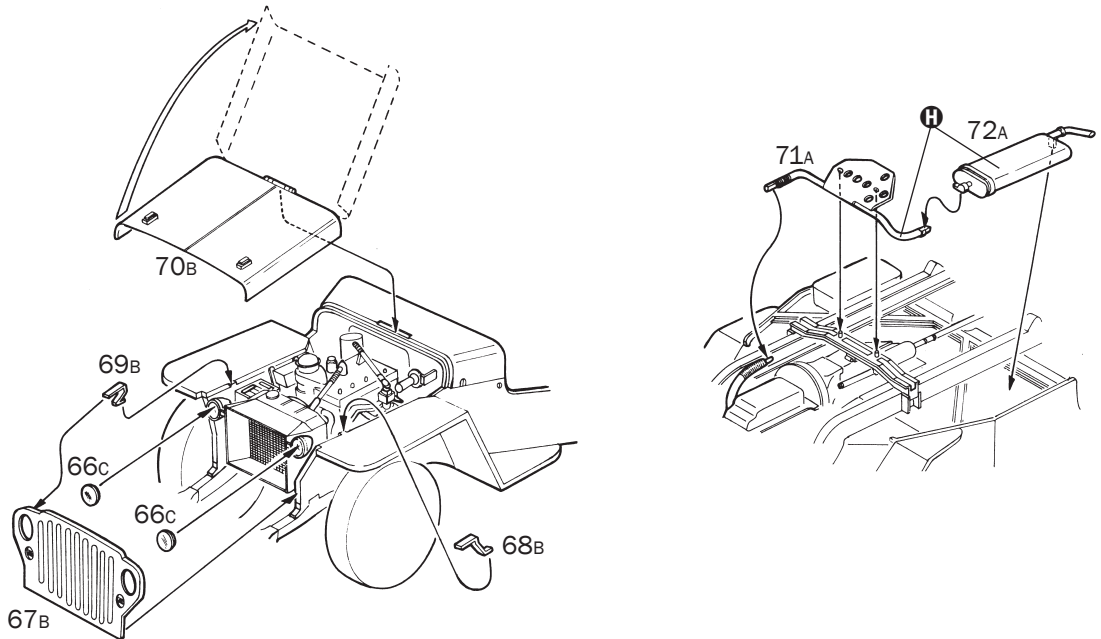

VERSION A

WILLYS JEEP, U.S. ARMY, 1ST INFANTRY DIVISION HQ, "OMAHA" BEACH, 6TH JUNE, 1944

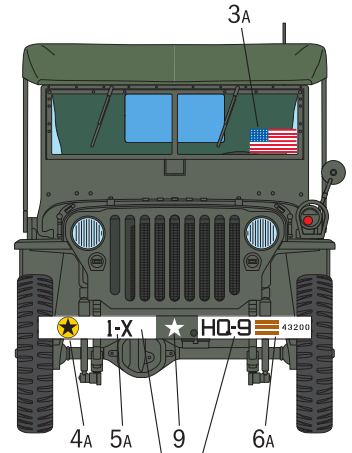
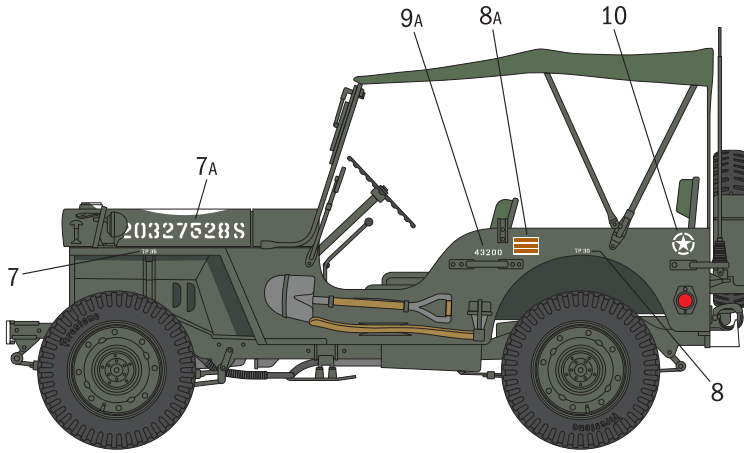

FLAT WHITE
F.S. 37875
ITALERI 4769AP

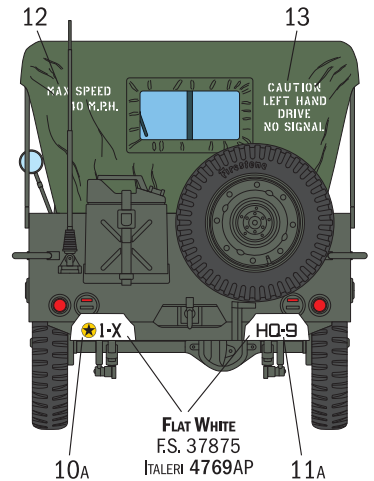
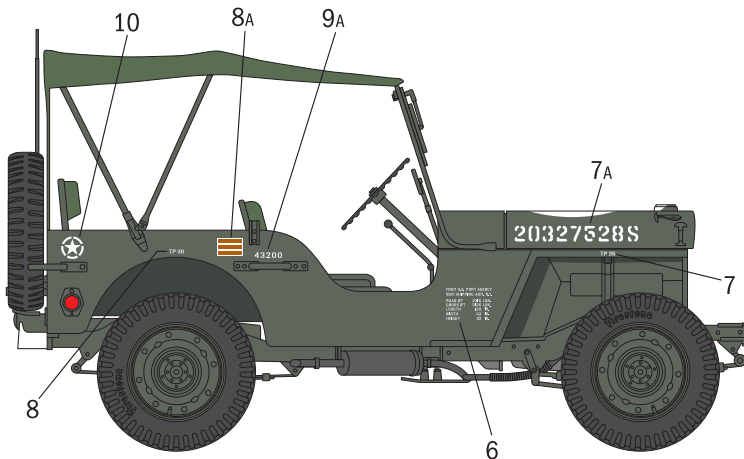

FLAT WHITE
F.S. 37875
ITALERI 4769AP

FLAT WHITE
F.S. 37875
ITALERI 4769AP

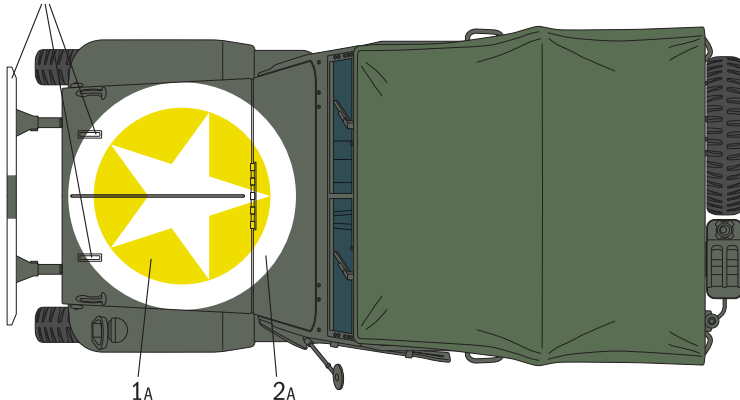

ALTERNATIVE RUBBER TYRES



OLIVE DRAB U.S. ARMY
F.S. 34084
ITALERI 4728AP

FIELD GREEN
F.S. 34097

VERSION B

WILLYS JEEP MB, U.S. ARMY, 2ND ARMORED DIVISION, 48TH MEDICAL BATTALION, NORMANDY, SUMMER 1944

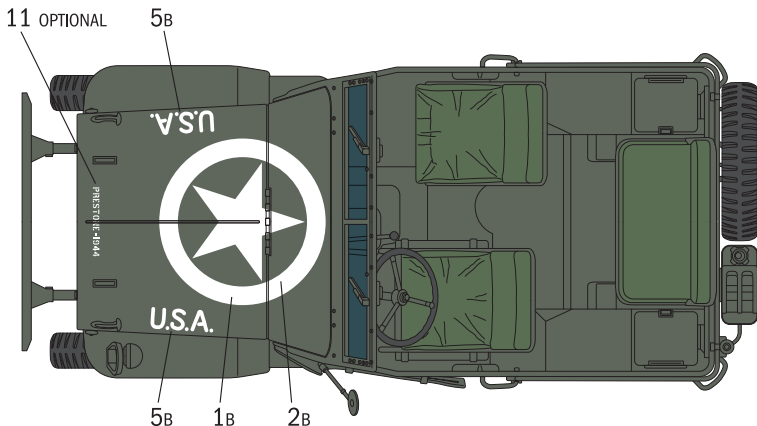
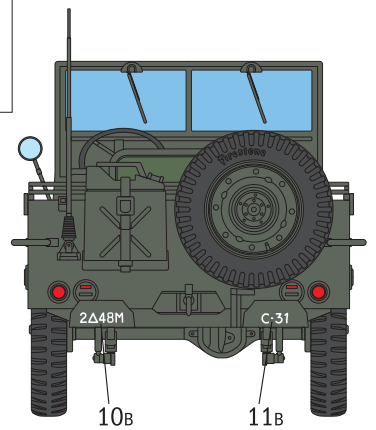
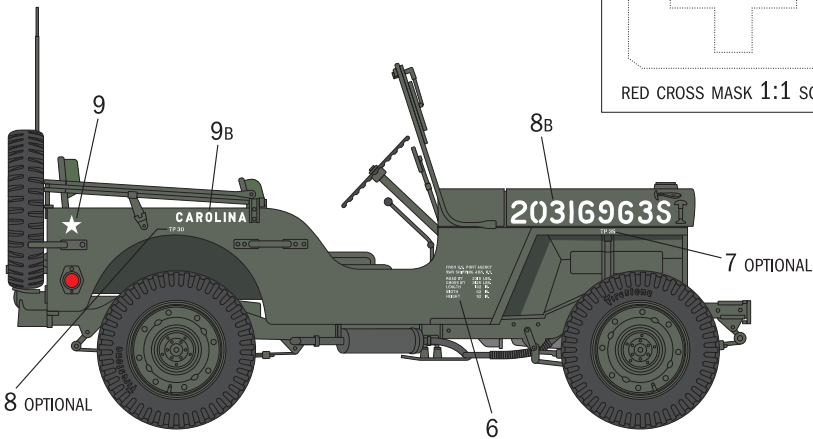
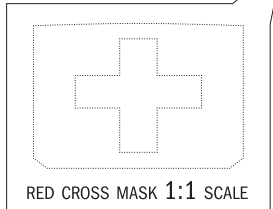
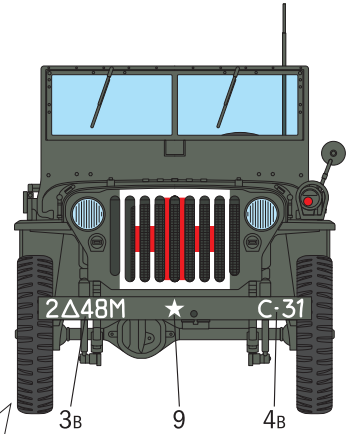
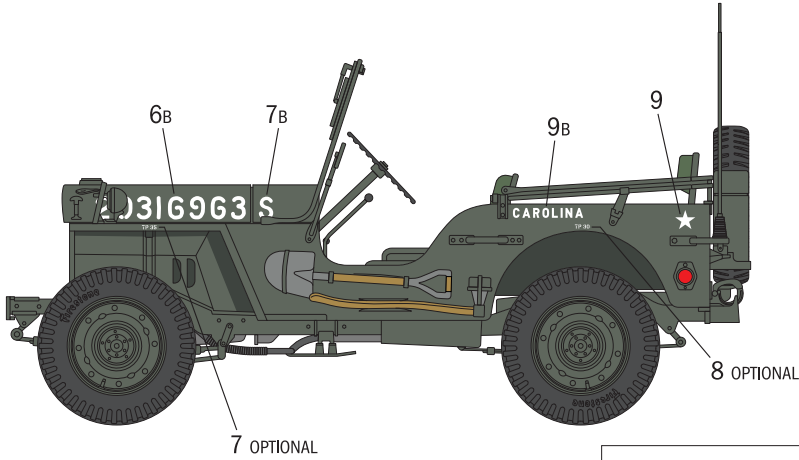

ALTERNATIVE RUBBER TYRES



OLIVE DRAB U.S. ARMY
F.S. 34084
ITALERI 4728AP

FIELD GREEN
F.S. 34097

VERSION C

WILLYS JEEP MB, U.S. ARMY, 101ST AIRBORNE DIVISION, 327TH GLIDER INFANTRY REGIMENT, BERCHTESGADEN, GERMANY, 1945

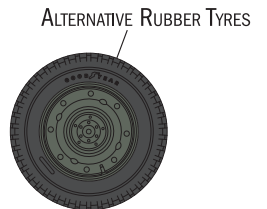
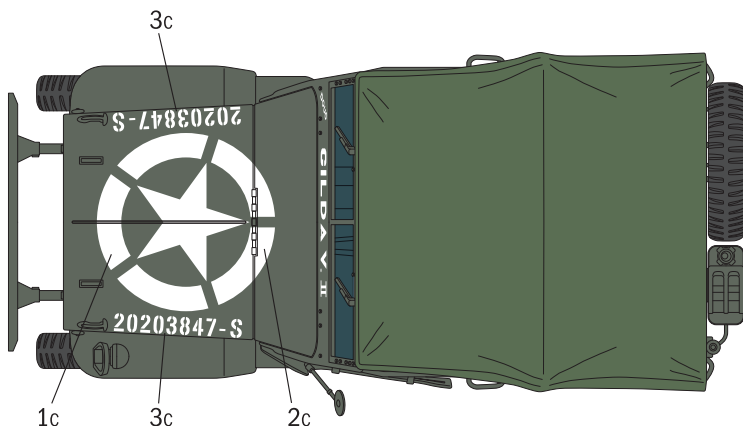
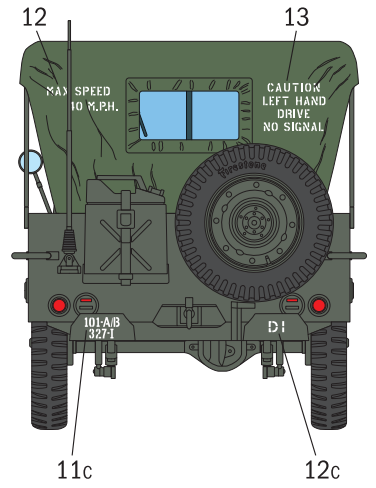
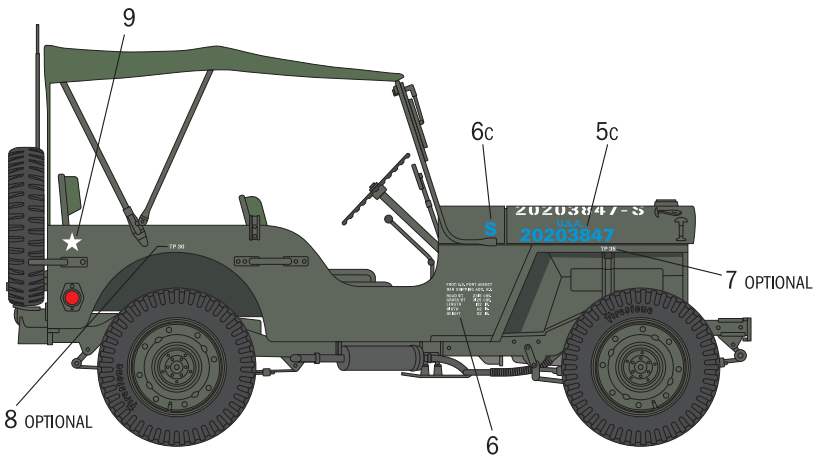
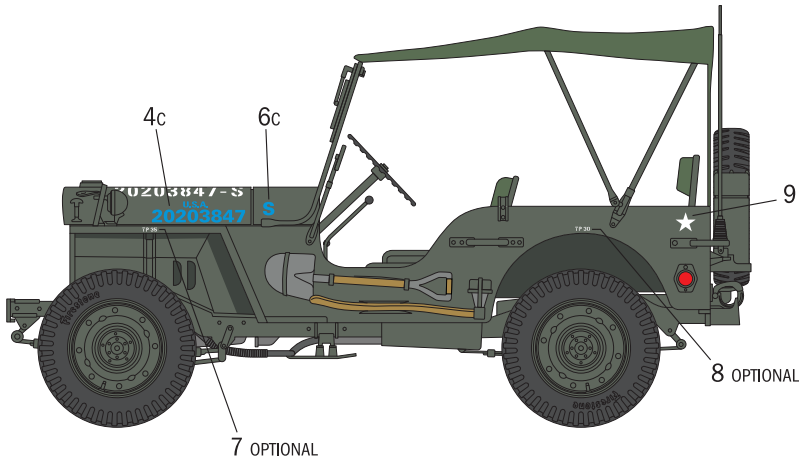

OLIVE DRAB U.S. ARMY
 F.S. 34084
 ITALERI 4728AP

FIELD GREEN
 F.S. 34097

VERSION D

WILLYS JEEP MB, U.S. ARMY, 6TH ARMORED DIVISION, 50TH ARMORED INFANTRY BATTALION, FRANCE, SUMMER 1944

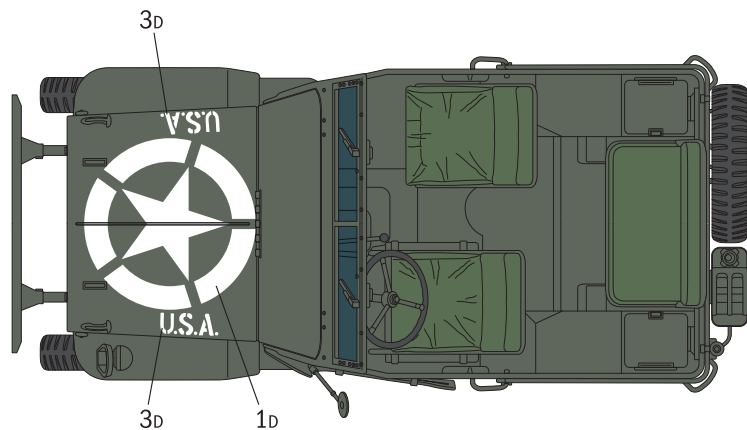
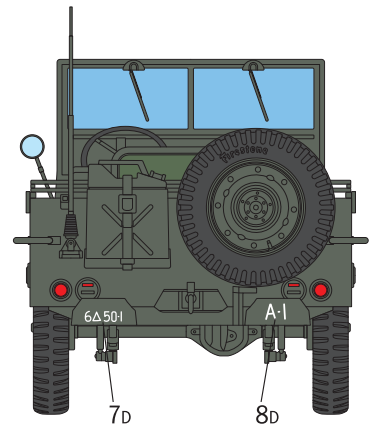
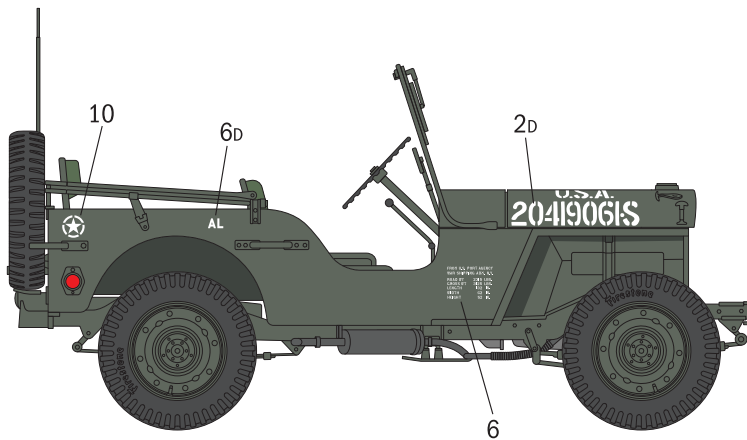
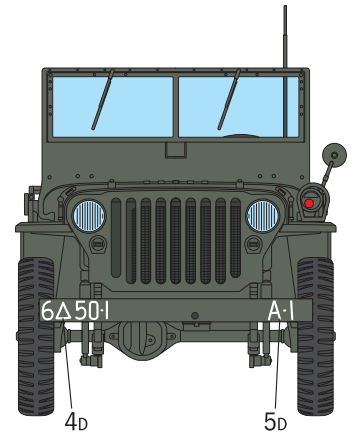
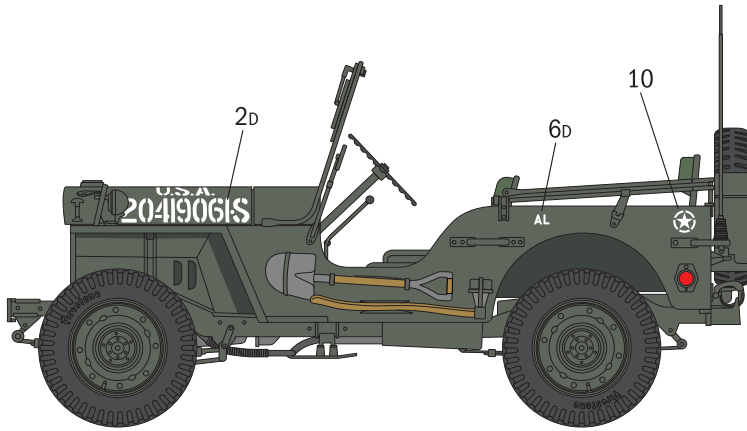

ALTERNATIVE RUBBER TYRES



OLIVE DRAB U.S. ARMY
F.S. 34084
ITALERI 4728AP

FIELD GREEN
F.S. 34097

VERSION E

WILLYS JEEP MB, BRAZILIAN EXPEDITIONARY FORCE (VTH ARMY), 1^{RO} REGIMIENTO DE FANTERIA, PELOTÃO DE POLICIA, NORTHERN ITALY, 1945

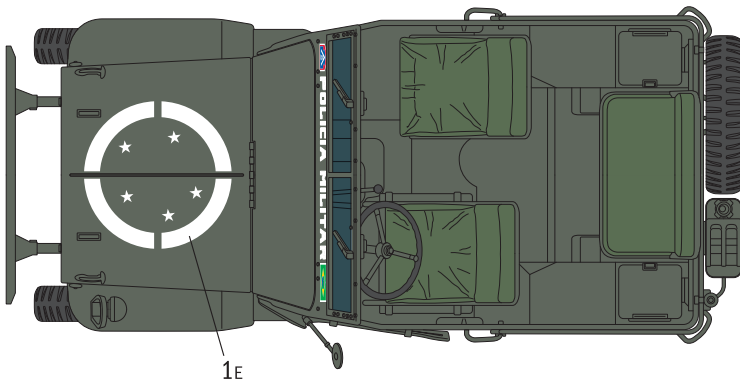
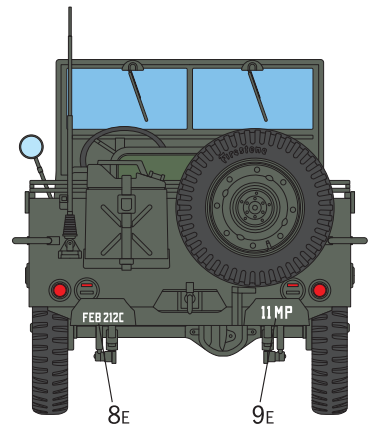
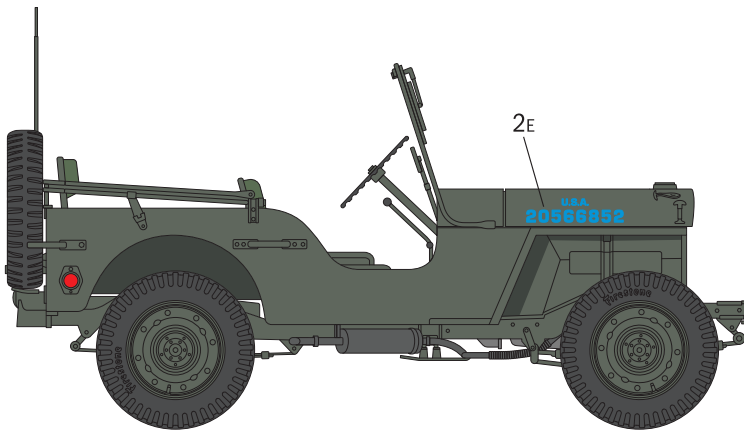
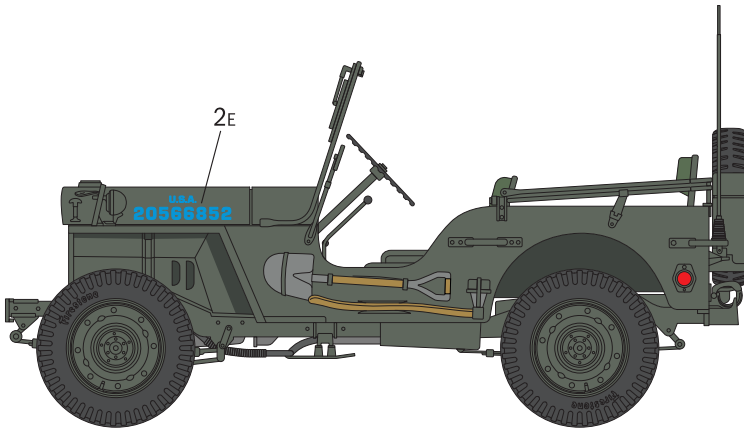

ALTERNATIVE RUBBER TYRES



OLIVE DRAB U.S. ARMY
F.S. 34084
ITALERI 4728AP

FIELD GREEN
F.S. 34097

VERSION F

WILLYS JEEP MB, U.S. NAVY SEABEES, MB NCB 6, GUADALCANAL, 1942

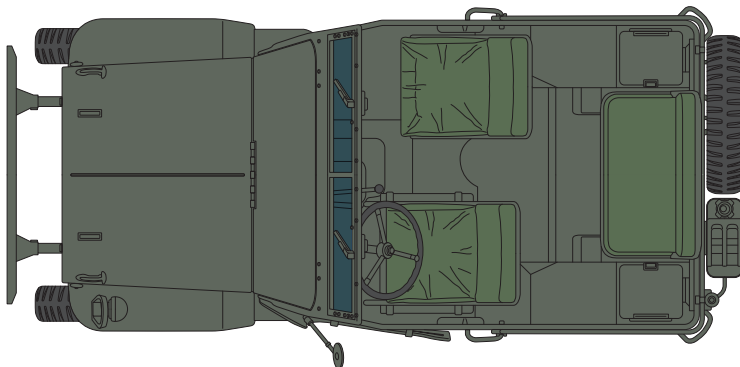
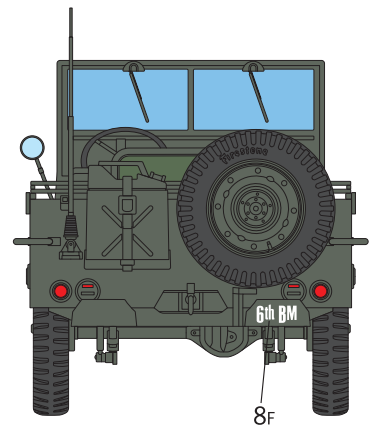
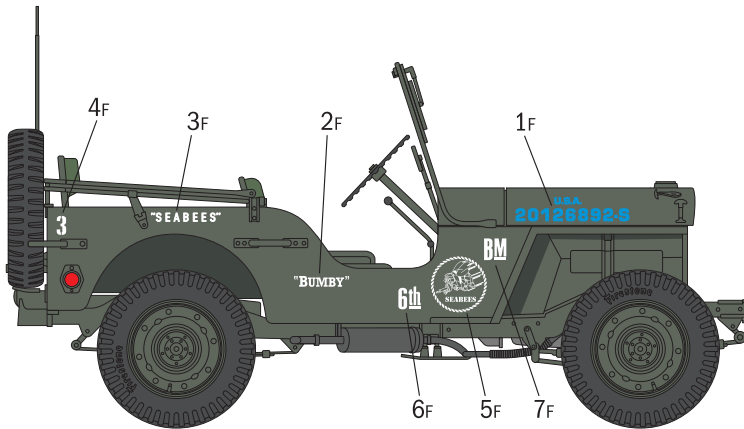
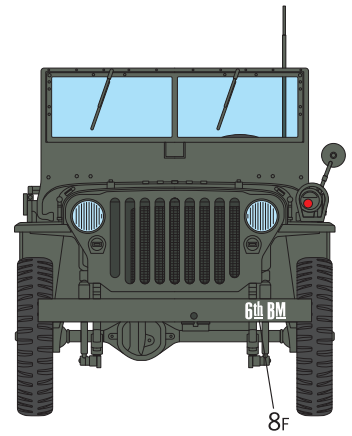
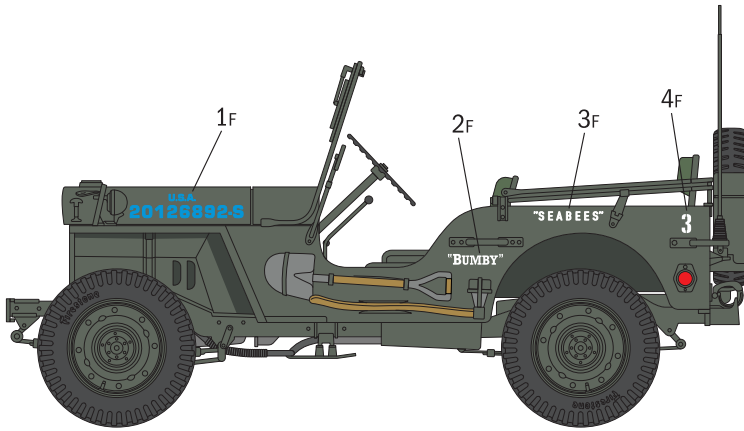

ALTERNATIVE RUBBER TYRES



OLIVE DRAB U.S. ARMY
F.S. 34084
ITALERI 4728AP

FIELD GREEN
F.S. 34097