

Made in Italy

1:48 scale

No 2826

# A-4E/F/G Skyhawk



EN

The Douglas A-4 Skyhawk was developed in the 1950s and was one of the most famous light attack aircraft in the aviation history. Its small and compact dimensions made it extremely maneuverable and ideal for use on the aircraft carriers. It was characterized by the low-mounted delta wing solution, the two small air intakes on the fuselage sides, and the adoption of the single Pratt & Whitney J52 turbojet engine. It was armed with two 20 mm. guns and, thanks to its hard points under the wings and under the fuselage the Skyhawk was able to support a wide variety of air-to-air missiles, air-to-surface missiles, rockets and bombs. Thanks to its operational capabilities, the A-4 scored a good commercial success and has been adopted by several air forces around the world. In addition to United States, it was used, among others, by Australia, New Zealand, Kuwait and Israel.

IT

Il Douglas A-4 Skyhawk venne sviluppato negli anni '50 e fu uno dei più celebri e diffusi aerei d'attacco leggero della Storia dell'aviazione. Le sue dimensioni piccole e compatte lo rendevano estremamente manovrabile e ideale per l'impiego sulle portaerei. Si caratterizzava per una design semplice, con le caratteristiche ali a delta basse e le piccole prese d'aria laterali, ma estremamente funzionale per gli impieghi operativi. Con l'adozione del motore turbogetto Pratt & Whitney J52 lo Skyhawk poteva raggiungere i 1.170 Km/h. Armato con due cannoni da 20 mm poteva trasportare un letale carico offensivo costituito da missili aria-aria, missili aria-superficie, razzi e bombe a caduta libera. Grazie alle sue caratteristiche operative, l'A-4 ebbe un notevole successo commerciale. Oltre che dagli Stati Uniti venne impiegato, tra gli altri, da Australia, Nuova Zelanda, Kuwait, Israele.

DE

Die Douglas A-4 Skyhawk wurde in den 1950er Jahren entwickelt und war eines der bekanntesten und beliebtesten leichten Angriffsflugzeuge der Luftfahrtgeschichte. Dank seiner kleinen und kompakten Größe war es äußerst wendig und ideal für den Einsatz auf Flugzeugträgern. Es zeichnete sich durch ein einfaches Design mit den charakteristischen niedrigen Deltaflügeln und kleinen seitlichen Lufteinlässen aus, war aber für den operationellen Einsatz äußerst funktionell. Durch den Einsatz des Pratt & Whitney J52-Turbotriebwerks konnte die Skyhawk 1.170 km/h erreichen. Bewaffnet mit zwei 20-mm-Kanonen konnte es eine tödliche Angriffslast tragen, die aus Luft-Luft-Raketen, Luft-Boden-Raketen, Raketen und frei fallenden Bomben bestand. Aufgrund ihrer Betriebseseigenschaften war A-4 ein beachtlicher kommerzieller Erfolg. Außer in den Vereinigten Staaten wurde es unter anderem auch in Australien, Neuseeland, Kuwait und Israel eingesetzt.

FR

Le Douglas A-4 Skyhawk a été développé dans les années 1950 et a été l'un des avions d'attaque légers les plus célèbres et les plus populaires de l'histoire de l'aviation. Sa petite taille et sa compacité le rendaient extrêmement maniable et idéal pour une utilisation sur les porte-avions. Il présentait une conception simple, avec ses ailes basses en forme de delta caractéristiques et ses petites prises d'air latérales, mais extrêmement fonctionnelle pour les utilisations opérationnelles. Avec l'adoption du moteur turbo-réacteur J52 de Pratt & Whitney, le Skyhawk pouvait atteindre 1 170 km/h. Armé de deux canons de 20 mm, il pouvait transporter une charge offensive létale composée de missiles air-air, de missiles air-surface, de roquettes et de bombes à chute libre. Grâce à ses caractéristiques opérationnelles, l'A-4 a connu un succès commercial considérable. Outre les États-Unis, il a été employé par l'Australie, la Nouvelle-Zélande, le Koweït et Israël, entre autres.

ES

El Douglas A-4 Skyhawk se desarrolló en la década de 1950 y fue uno de los aviones de ataque ligero más famosos y populares de la historia de la aviación. Su tamaño pequeño y compacto lo hacía extremadamente maniobrable e ideal para su uso en portaaviones. Presentaba un diseño sencillo, con sus características alas delta bajas y pequeñas tomas de aire laterales, pero era extremadamente funcional para su uso operativo. Con la adopción del motor turbo-reactor Pratt & Whitney J52, el Skyhawk podía alcanzar los 1.170 km/h. Armado con dos cañones de 20 mm, podía transportar una carga ofensiva letal consistente en misiles aire-aire, misiles aire-tierra, cohetes y bombas de caída libre. Debido a sus características operativas, el A-4 tuvo un considerable éxito comercial. Además de Estados Unidos, lo emplearon Australia, Nueva Zelanda, Kuwait e Israel, entre otros.

RU

Самолет Дуглас А-4 «Скайхок» был разработан в 1950-х годах и стал одним из самых известных и популярных легких штурмовиков в истории авиации. Небольшой и компактный размер сделал его чрезвычайно маневренным и идеальным для использования на авианосцах. Он отличался простой конструкцией с характерными низкими трёхлонжеронными крыльями и небольшими боковыми воздухозаборниками, но был чрезвычайно функциональным для оперативного использования. После принятия на вооружение турбореактивного двигателя «Прат энд Уитни» J52, «Скайхок» мог разогнаться до 1170 км/ч. Вооруженный двумя 20-мм пушками, он мог нести смертоносную боевую нагрузку, состоящую из ракет класса "воздух-воздух", "воздух-земля", ракет и бомб свободного падения. Благодаря своим эксплуатационным характеристикам А-4 имел значительный коммерческий успех. Помимо США штурмовик применялся в Австралии, Новой Зеландии, Кувейте, Израиле и в других странах.



- EN WARNING:** Model for adult modellers age 14 and over
- IT ATTENZIONE:** Modello per collezionisti adulti di età superiore ai 14 anni
- FR ATTENTION:** Modèle pour modélistes de 14 and et plus.
- DE ACHTUNG:** Modellbausatz für Modellbauer über 14 Jahre.
- NL WAARSCHWING:** Geschikt voor 14 jaar en ouder.
- ES ATENCION:** Modelo para modelistas mayores de 14 años.

## EN ATTENTION - Useful advice!

STUDY THE INSTRUCTIONS CAREFULLY PRIOR TO ASSEMBLY. REMOVE PARTS FROM FRAME WITH A SHARP KNIFE OR A PAIR OF SCISSOR AND TRIM AWAY EXCESS PLASTIC. DO NOT PULL OIL PARTS. ASSEMBLE THE PARTS IN NUMERICAL SEQUENCE. USE PLASTIC CEMENT ONLY AND USE CEMENT SPARINGLY TO AVOID DAMAGING THE MODEL. BLACK ARROWS INDICATE PARTS TO BE GLUED TOGETHER. WHITE ARROWS INDICATE ON WHICH FRAME THE PARTS MUST BE ASSEMBLED WITHOUT USING CEMENT. THESE LETTERS (A - B - C...) INDICATE ON WHICH FRAME THE PARTS WILL BE FOUND. PAINT SMALL PARTS BEFORE DETACHING THEM FROM FRAME. REMOVE PAINT WHERE PARTS ARE TO BE CEMENTED. CROSSED OUT PARTS MUST NOT BE USED.

## IT ATTENZIONE - Consigli utili!

PRIMA DI INIZIARE IL MONTAGGIO STUDIARE ATTENTAMENTE IL DISEGNO. STACCARE CON MOLTA CURA I PEZZI DALLE STAMPATE. USANDO UN TAGLIA-BALSA OPPURE UN PAIO DI FORBICI TOGLIERE CON UNA PICCOLA LAMA O CON CARTA VETRO FINE EVENTUALI SBARATURE. MA STOCARE I PEZZI CON LE MANI. MONTARLI SEGUENDO L'ORDINE DELLE NUMERAZIONI DELLE TAVOLE. ELIMINARE DALLA STAMPATA IL NUMERO DEL PEZZO APPENA MONTATO FACENDOLI SOPRA UNA CROCE. LE FRECCIE NERE INDICANO I PEZZI DA INCOLLARE. LE FRECCIE BIANCHE INDICANO I PEZZI DA MONTARE SENZA COLLA. USARE SOLO COLLA PER POLISTIROLO. LE LETTERE (A - B - C...) AI LATI DEI NUMERI INDICANO LA STAMPATA OVE SI TROVA IL PEZZO DA MONTARE. I PEZZI SBARRATI DA UNA CROCE NON SONO DA UTILIZZARE.

## DE ACHTUNG - Ein nützlicher Rat!

VOR DER MONTAGE DIE ZEICHNUNG AUFRÄHMIG STUDIERT. DIE EINZELNEN MONTAGETEILE MIT EINEM MESSER ODER EINER SCHERE VOM SPRITZLUNG SORFÄLIG ENTFERNEN. EVENTUELLE GRÄTE WERDEN MIT EINER KLINGE ODER FEINEM SCHMIRGELPAPIER BESEITIGT. KEINESFALLS DIE MONTAGETEILE MIT DEN HÄNDEN ENTFERNEN. BEI DER MONTAGE DER TAFELNUMERIERUNG FOLGEN. PFEILE ZEIGEN DIE ZU KLEBENDEN TEILE WÄHREND DIE WEISSEN PFEILE DIE OHNE LEIM ZU MONTIERENDEN TEILE ANZEIGEN. BITTE NUR PLASTIKLEBSTOFF VERWENDEN. DIE BUCHSTABEN (A - B - C...) NEBEN DEN NUMEREN ZEIGT AUF WELCHEM SPRITZLUNG DER ZU MONTIERENDE TEIL ZU FINDEN IST. DIE MIT EINEM KREUZ MARKIERTEN TEILE SIND NICHT ZU VERWENDEN.

## FR ATTENTION - Conseils utiles!

AVANT DE COMMENCER LE MONTAGE. ÉTUDIER ATTENTIVEMENT LE DESSIN. DÉTACHER AVEC BEAUCOUP DE SOIN LES MORCEAUX DES MOULDES EN USANT UN MASSICOT OU BIEN UN PAIR DE Ciseaux ET COUPER AVEC UNE PETITE LAME AVEC DE PAPIER DE VITRE FIN ÉBARBÉS ÉVENTUELS. JAMAIS DÉTACHER LES MORCEAUX AVEC LE MAINS MONTER LES EN SUIVANT L'ORDRE DE LA NUMÉRATION DES TABLES. ÉLIMINER DE LA MOULLE LE NUMÉRO DE LA PIÈCE QUI VIENT D'ÊTRE MONTÉE. EN LE BIFFANT AVEC UNE CROIX. LES FLÈCHES NOIRÉS INDIQUENT LES PIÈCES À COLLER. LES FLÈCHES BLANCHES INDIQUENT LES PIÈCES À MONTER SANS COLLE. EMPLOYER SEULEMENT DE LA COLLE POUR POLYSTYROL. LES LETTRES (A - B - C...) AUX CÔTÉS DES NUMÉROS INDIQUENT LA MOULLE OÙ SE TROUVE LA PIÈCES À MONTER. LES PIÈCES MARQUÉES PAR UNE CROIX NE SONT PAS À UTILISER.

## ES ATENCION - Consejos útiles!

ESTUDIAR LAS INSTRUCCIONES CUIDADOSAMENTE ANTES DE COMENZAR EL MONTAJE. SEPARAR LAS PIEZAS DE LAS BANDejas CON UN CUCHILLO AFILADO O UN PAIR DE TIJERAS Y RETIRAR EL EXCESO DE PLÁSTICO O REBADA. NO ARRANCAR LAS PIEZAS. MONTAR LAS PIEZAS EN ORDEN NUMÉRICO. UTILIZAR SOLAMENTE PEGAMENTO PARA PLÁSTICO Y EN POCA CANTIDAD PARA EVITAR QUE SE DANÉ EL MODELO. LAS FLECHAS NEGRAS INDICAN LAS PIEZAS QUE SE DEBEN PEGAR JUNTAS. LAS FLECHAS BLANCAS INDICAN LAS PIEZAS QUE DEBEN ENSAMBLARSE SIN USAR PEGAMENTO. LAS LETRAS (A - B - C...) INDICAN EN QUE BANDEJA SE ENCUENTRAN LAS PIEZAS. PINTAR LAS PIEZAS PEQUEÑAS ANTES DE SEPARARLAS DE LA BANDEJA. RETIRAR LA PINTURA DE LOS LUGARES POR DONDE SE DEBEN PEGAR LAS PIEZAS.

## RU ПРЕДУПРЕЖДЕНИЕ - важные!

ПЕРЕД ТЕМ, КАК ПРИСТУПИТЬ К СБОРКЕ, ВНИМАТЕЛЬНО ИЗУЧИТЬ ЧЕРТЕЖИ. ОЧЕНЬ ОСТОРОЖНО ОТСОЕДИНЯТЬ РАСТЕЧАЩИЕСЯ ЭЛЕМЕНТЫ. ИСПОЛЬЗОВАТЬ ДЛЯ ЭТОГО КАНЦЕЛЛАРСКИЙ НОЖ ИЛИ ПАРУ НОЖИЦ, СНЯТЬ НЕРОВНОСТИ С ПОМОЩЬЮ ТОНКОГО ЛЕЗВИЯ ИЛИ С ПОМОЩЬЮ АБРАЗИВНОЙ БУМАГИ. НЕ ОТСОЕДИНЯТЬ ЭЛЕМЕНТЫ РУКАМИ. ВЫПОЛНИТЬ СБОРКУ СОГЛАСНО ПОРЯДКУ НУМЕРАЦИИ ТАБЕЛИ. УДАЛИТЬ ИЗ ОТПЕКА ТОЛЬКО ТО СООБРАЖАЮЩАЯ ЕЕ. ЧЕРНЫЕ СТРЕЛКИ УКАЗЫВАЮТ ДЕТАЛИ ДЛЯ СБОРКИ, БЕЛЫЕ СТРЕЛКИ УКАЗЫВАЮТ ДЕТАЛИ, КОТОРЫЕ СОБИРАЮТСЯ БЕЗ КЛЕЯ. ИСПОЛЬЗОВАТЬ ТОЛЬКО КЛЕЙ ДЛЯ ПЕНОПЛАСТА. БУКВЫ (A - B - C...) НА ПРОНУМЕРОВАННЫХ СТОРОНАХ УКАЗЫВАЮТ АМТ, ГДЕ НАХОДИТСЯ ДЕТАЛЬ. ПЕРЕКРЫТЫЕ ДЕТАЛИ НЕ ИСПОЛЬЗОВАТЬ.

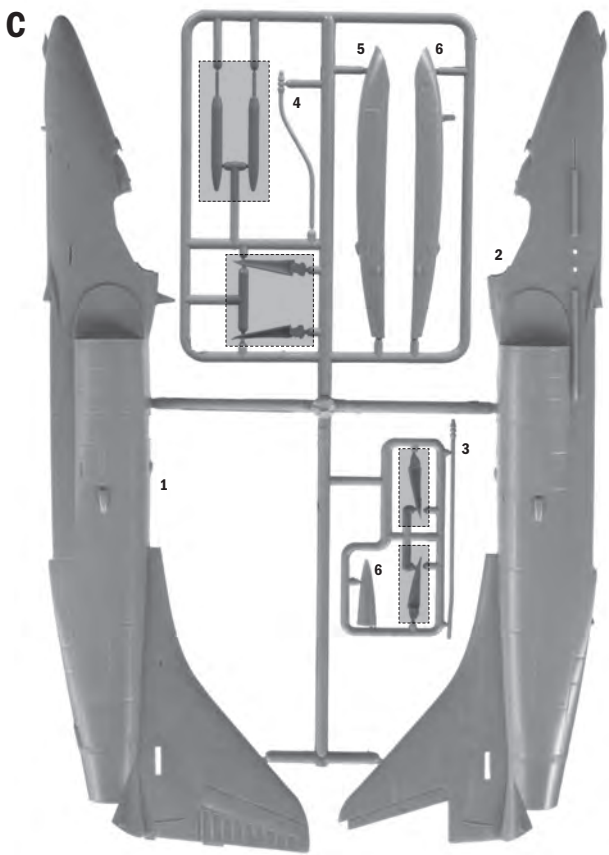
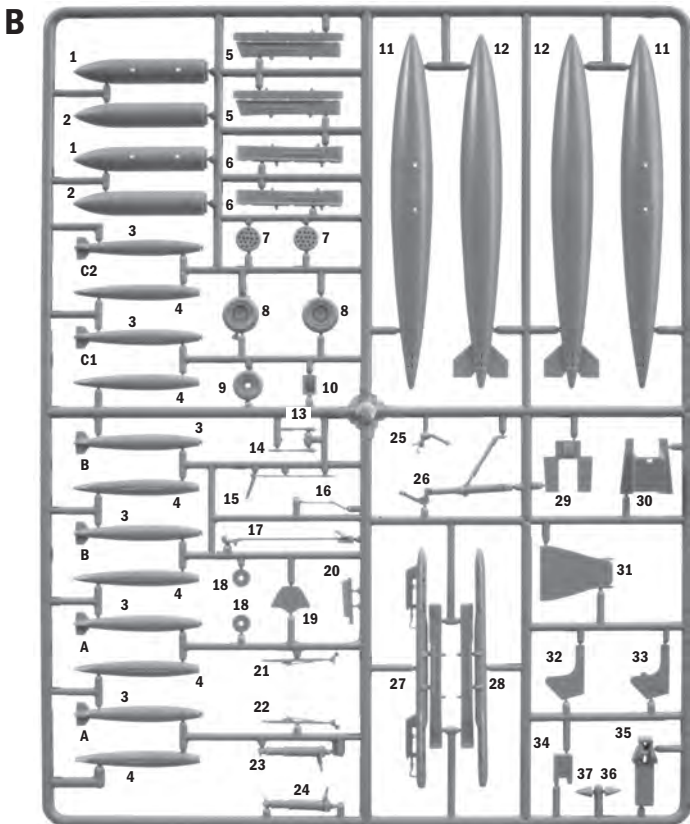
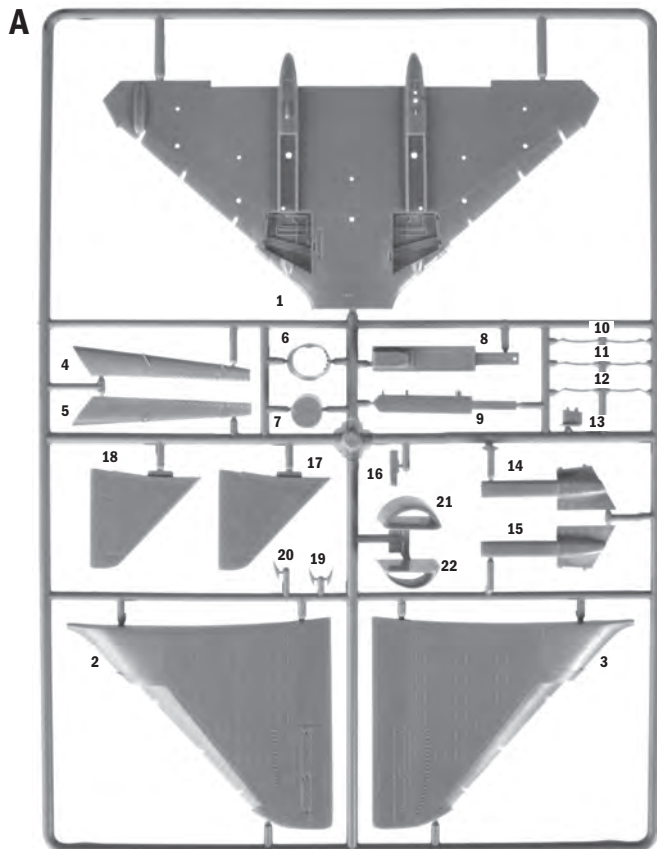

Aggiungere un peso  
Add a weight  
Ajouter un poids  
Fügen Sie ein Gewicht



Separare  
Cut  
Retirer  
Entfernen



Parti da non utilizzare  
Parts not for use  
Pièces à ne pas utiliser  
Telle werden nicht verwenden

## SUGGESTED COLORS

**A**

FLAT LIGHT GRAY  
F.S. 36495

ITALERI ACRYLICPAINT - 4763AP

**B**

FLAT MEDIUM GRAY  
F.S. 36270

ITALERI ACRYLICPAINT - 4755AP

**C**

FLAT BLACK  
F.S. 37038

ITALERI ACRYLICPAINT - 4768AP

**D**

FLAT WHITE  
F.S. 37875

ITALERI ACRYLICPAINT - 4769AP

**E**

FLAT OLIVE DRAB  
F.S. 37087

ITALERI ACRYLICPAINT - 4728AP

**F**

FLAT RED  
F.S. 31400

ITALERI ACRYLICPAINT - 4606AP

**G**

METAL FLAT ALUMINIUM  
F.S. 37178

ITALERI ACRYLICPAINT - 4677AP

**H**

FLAT GUN METAL  
F.S. 37200

ITALERI ACRYLICPAINT - 4681AP

**I**

GLOSS GREEN  
F.S. 14090

ITALERI ACRYLICPAINT - 4669AP

**1**

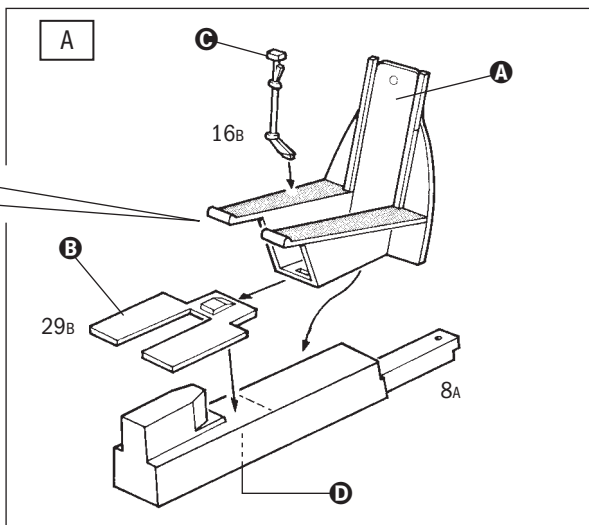
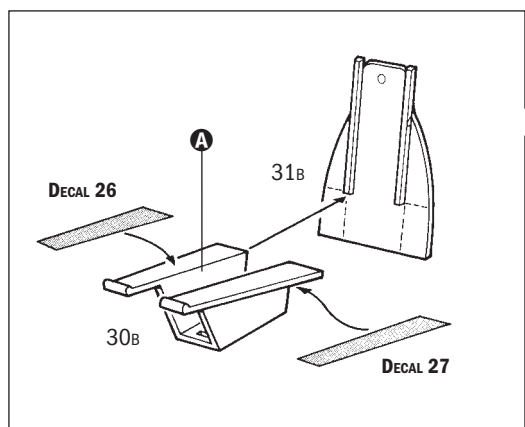

2

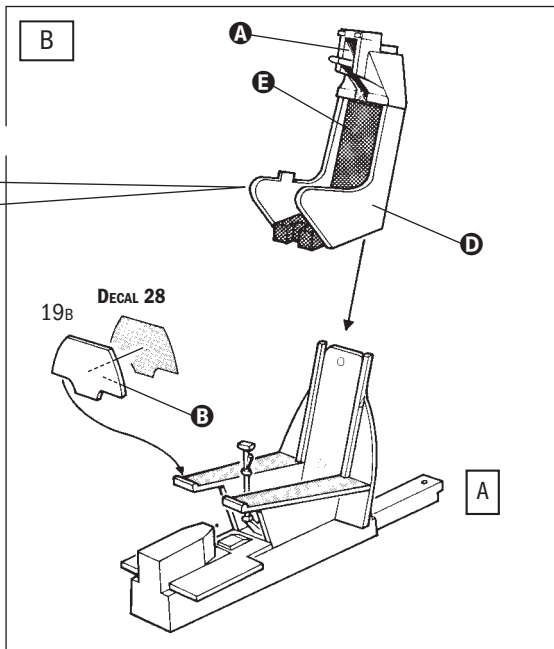
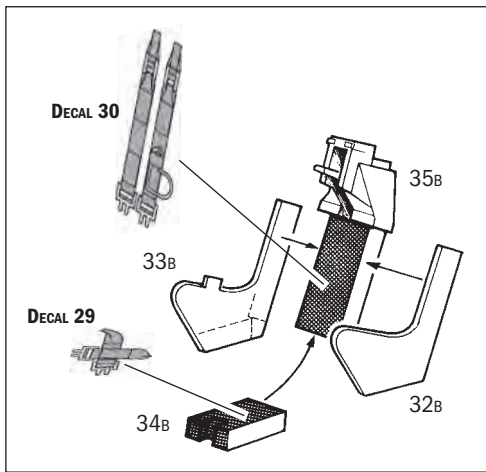

3

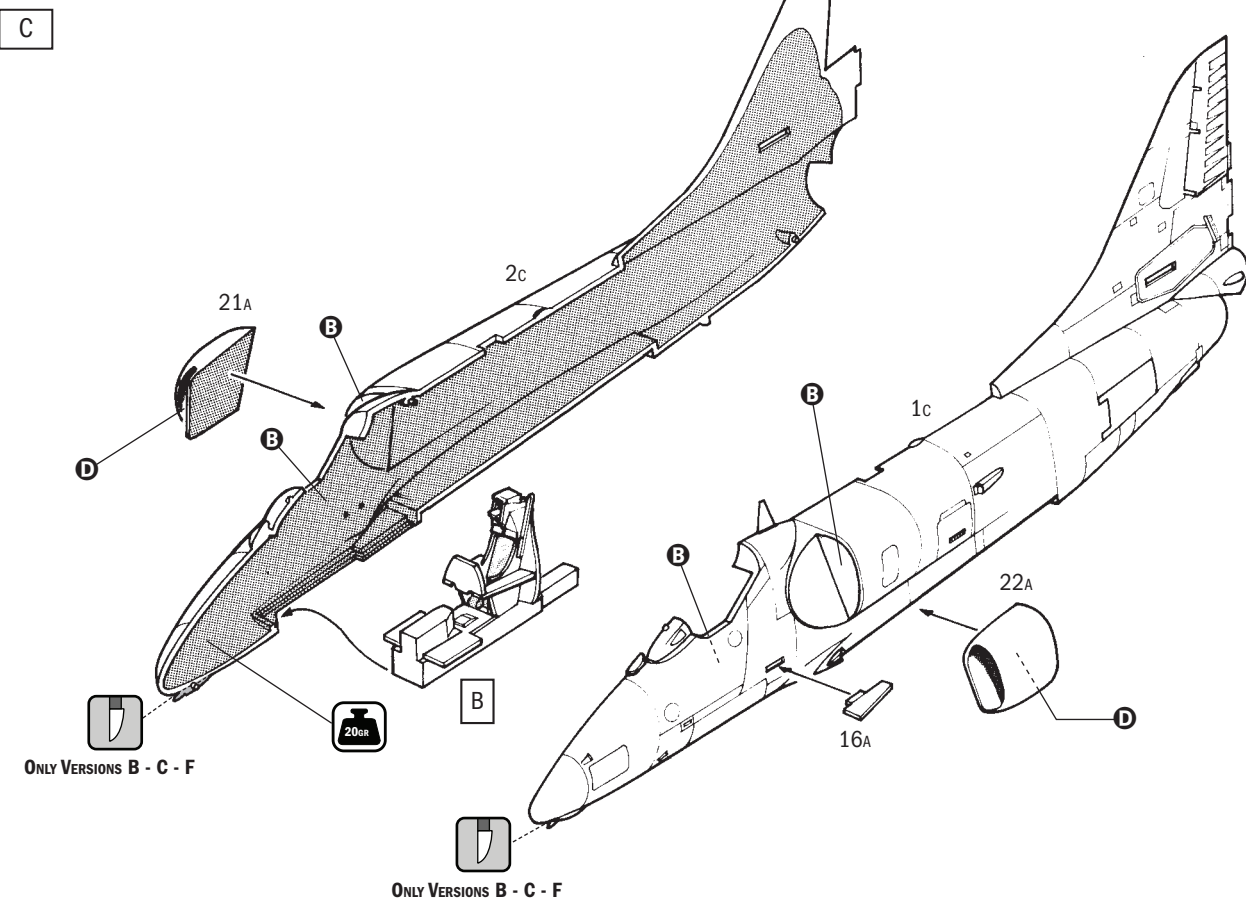

4

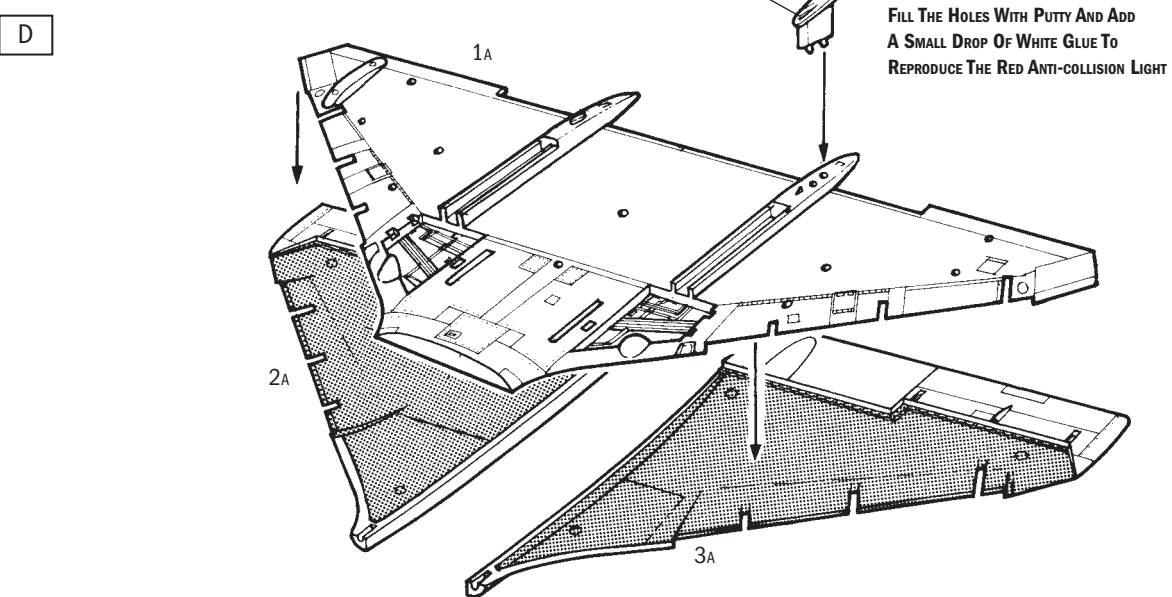

# 5

F

SUGGESTION:  
APPLY THE WING DECALS BEFORE  
ASSEMBLING THE OUTER PYLONS.  
SEE THE FINAL COLOR PLATE!

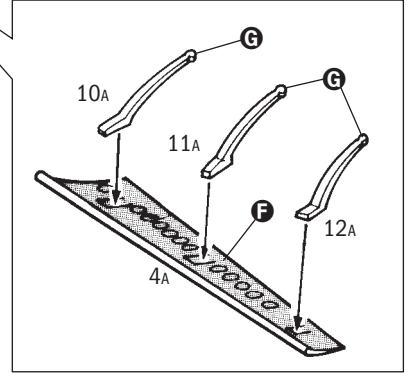
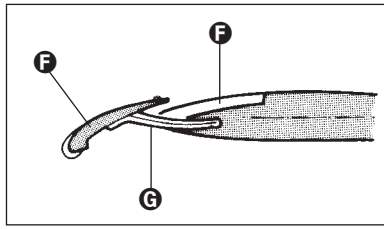
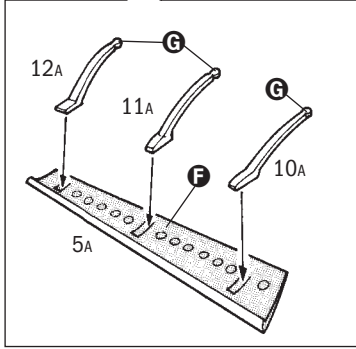
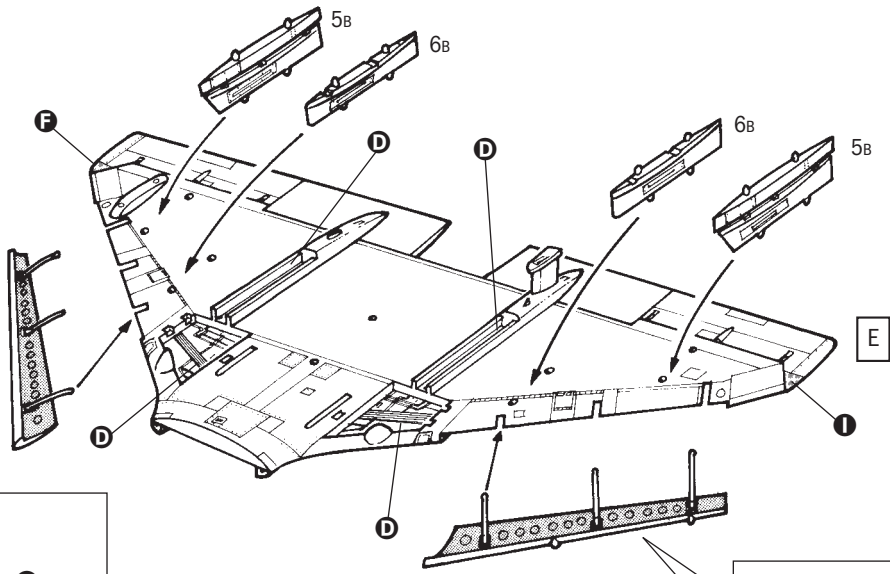

# 6

ONLY VERSIONS D - E

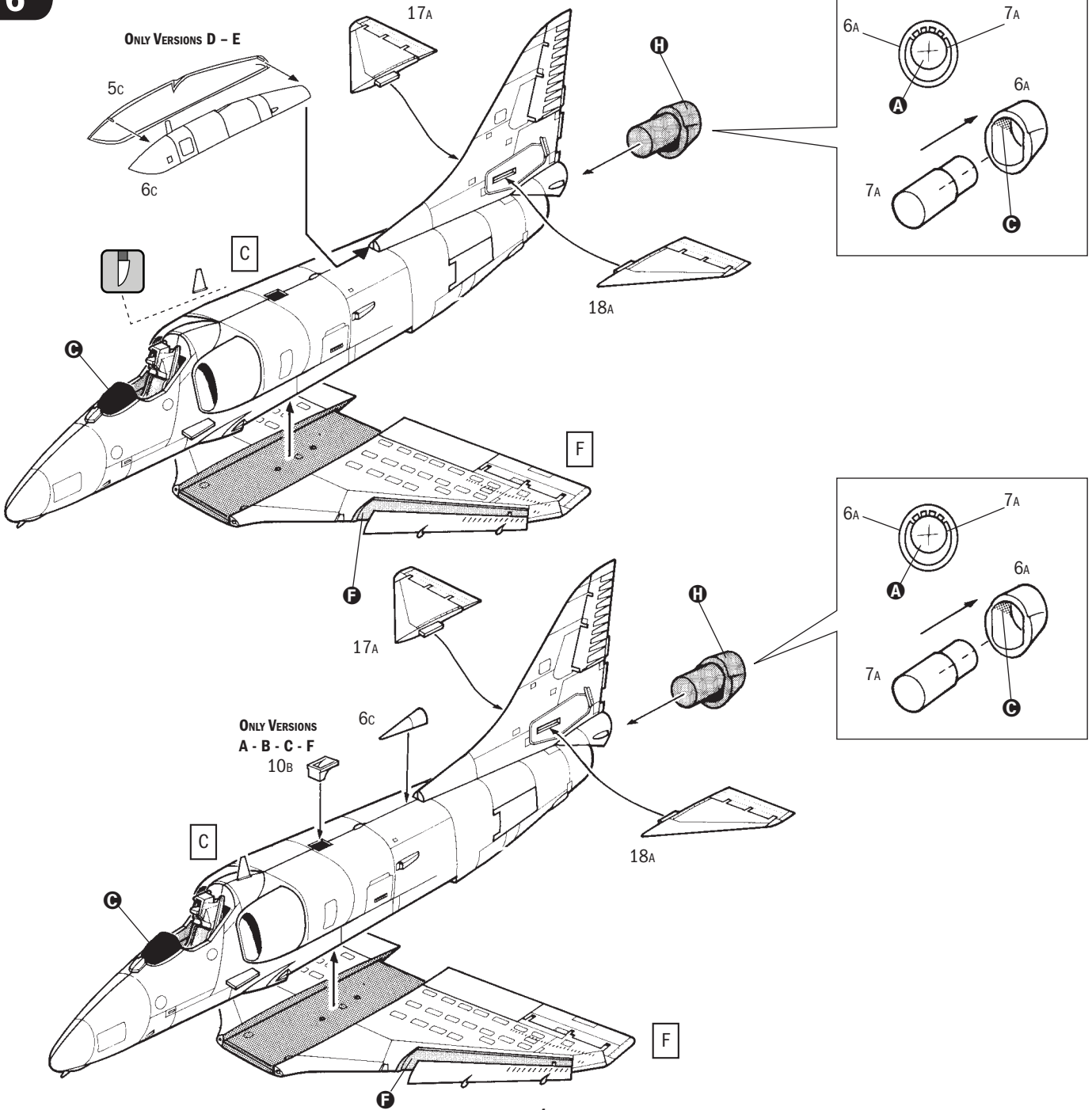

ONLY VERSIONS  
A - B - C - F  
10B



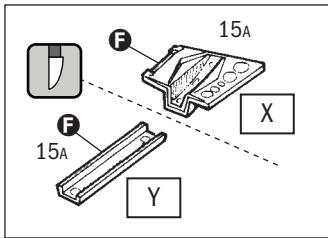
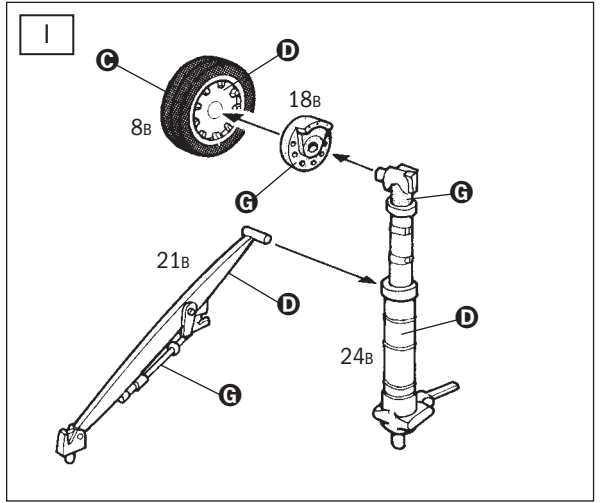
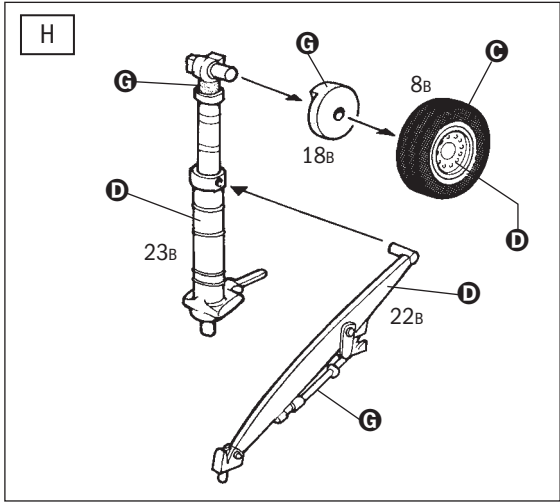
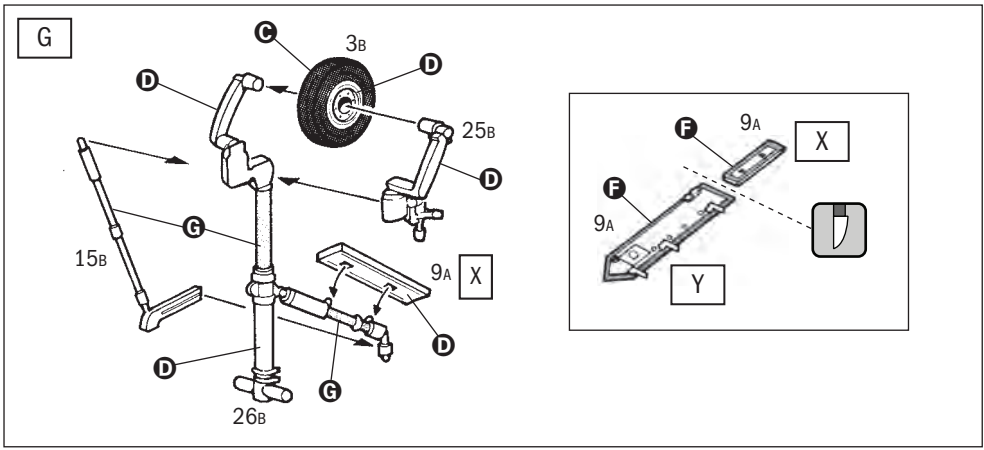

IN VERSIONS A - D PAINT THE EDGE OF LANDING GEAR DOORS IN FLAT RED

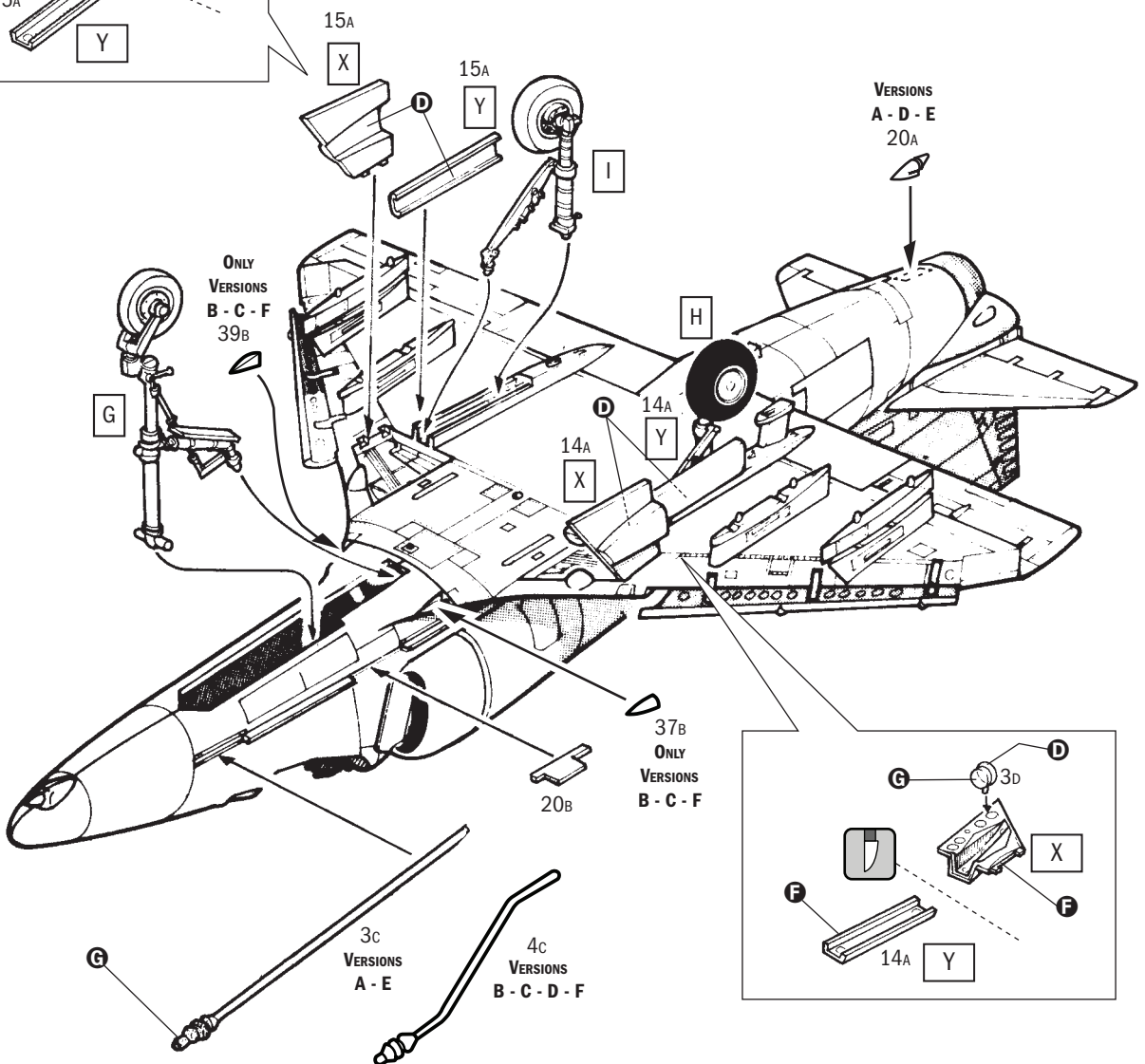

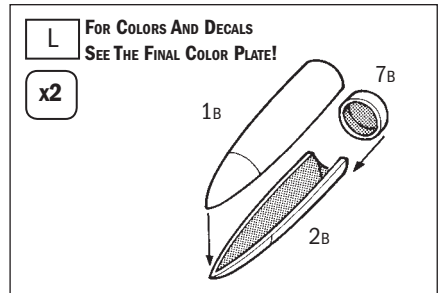
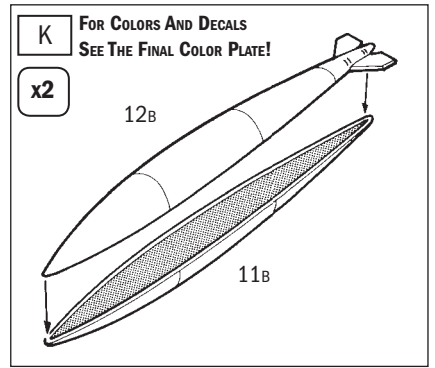
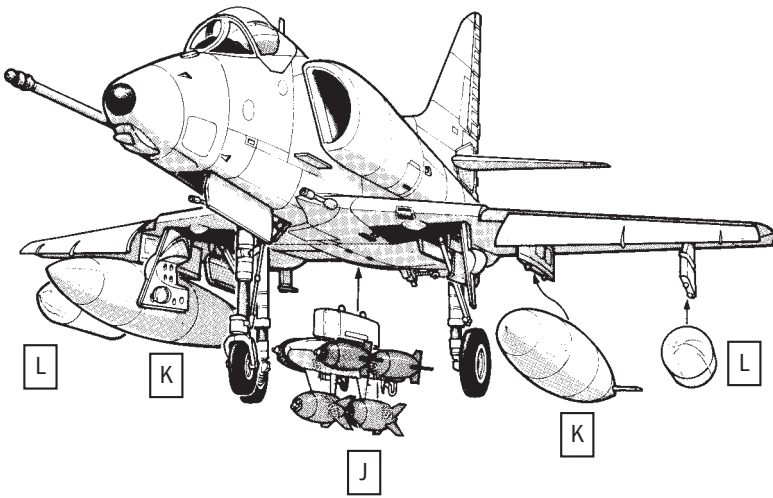
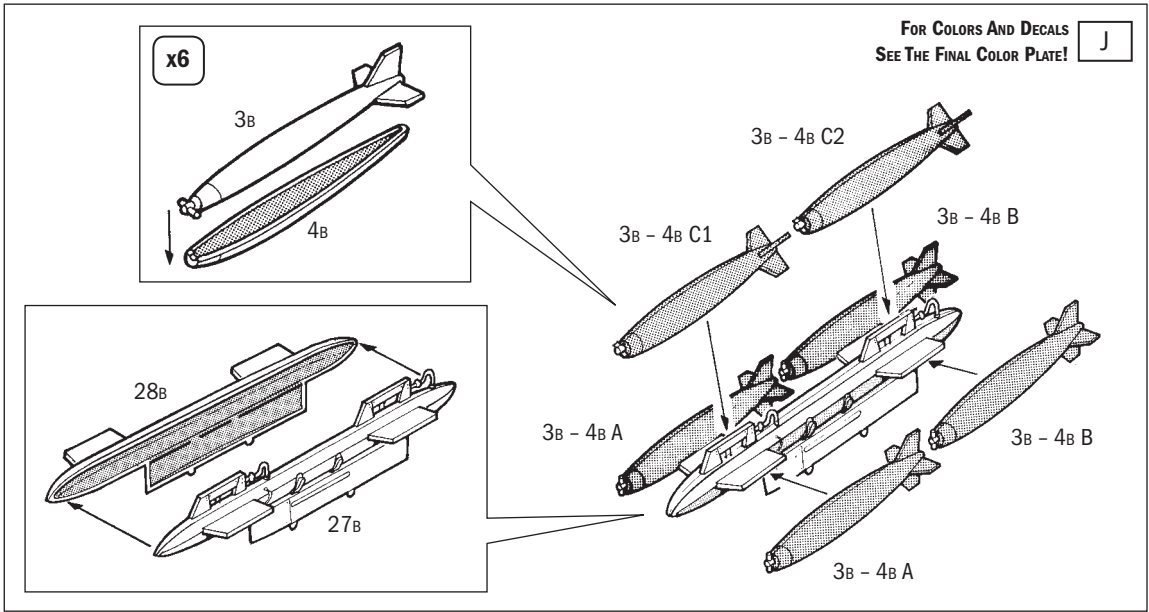
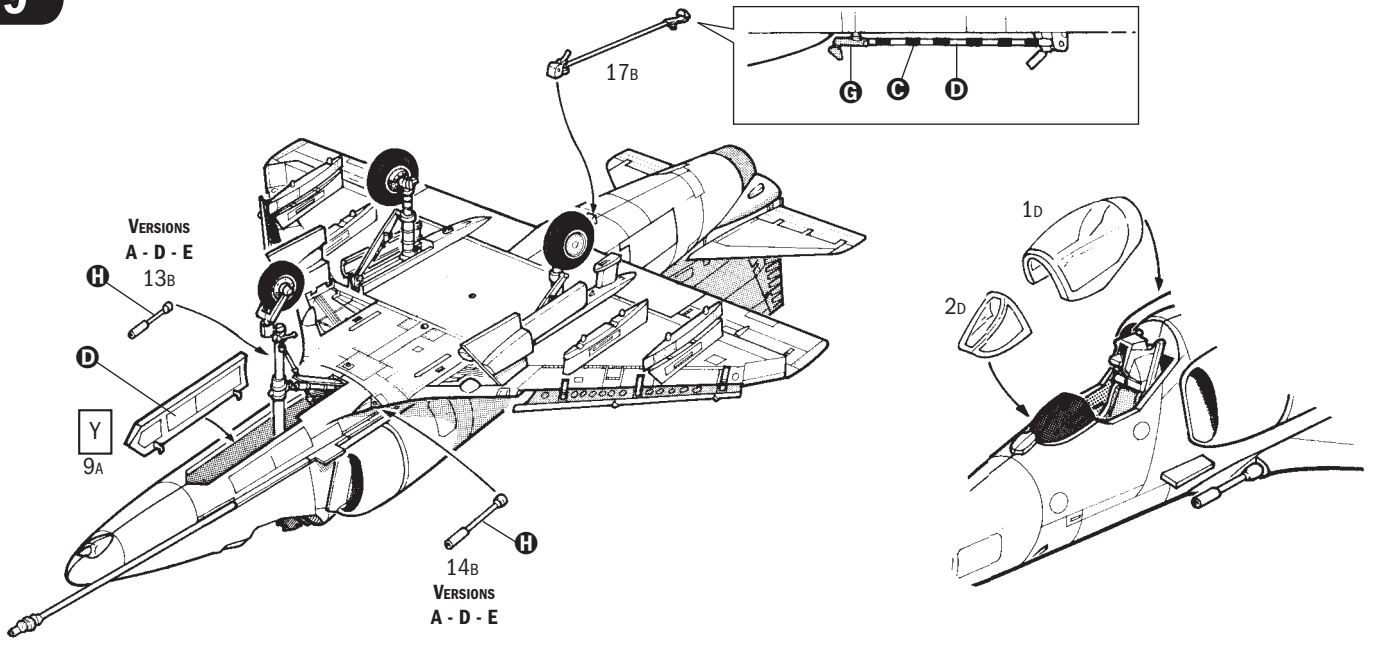

Istruzioni per l'applicazione delle decalcomanie. Ritagliare le decalcomanie occorrenti dal foglio, immergerle in un bicchiere di acqua pulita per circa 20", metterle in posizione sul modello e farle scivolare dalla carta: per una migliore aderenza comprimerle con una pezzuola pulita.

Direction for applying the decals: cut the required decals out of the sheet; dip the into a glass of clean water for about 20"; position the decals on the kit, letting them slide from the paper. For a better adhesion, press them by means of a clean rag.

Påläggning av decal: klipp ut den decal som skall användas och doppa den i ett glas vatten under en 20". Sätt decalen på plats på modellen och låt den sakta glida av pappret. För att den skall sitta ordentligt, tryck till med en torr duk.



Anweisungen für Abziehbilder-Anbringung: Die benötigten Abziehbilder vom Blatt abschneiden, in ein Glas reines Wasser für etwa 20" eintauchen, auf das Modell legen und dann vom Papierbogen abnehmen. Um eine bessere Haftung zu erzielen, die Abziehbilder mit einem reinen Tuch andrücken.

Instruction pour l'application des décalcomanies. Couper les décalcomanies choisies et les plonger environ 20" dans un peu d'eau propre. Les placer sur le modèle en les faisant glisser de leur feuille et presser avec un morceau de chiffon pour éliminer les bulles d'air.

Istrucciones Para la aplicación de las calcomanías: cortar las requeridas, sumergirlas en un recipiente de agua limpia durante 20", colocar las calcomanías sobre el modelo, haciéndolas deslizar sobre el papel. Para una mejor adherencia, presionarlas con un trapito limpio.

Transfers: knip het benodigde deel uit, dompel et ca. 20" onder water, duid het transfer tegen het model en schuif het vanaf het papier op zijn plaats. Met een schoon doekje aandrukken.

For application of the decals: cut the required decals out of the sheet, immerse them in a glass of clean water for about 20 minutes, position the decals on the model, letting them slide from the paper. For a better adhesion, press them with a clean rag.

Указания по применению декалей: Отрежьте нужную вам часть декалей от общего листа, поместите ее на 20" минуты в чистую воду, затем, выждав необходимое время, переведите туда необходимые, сдвигая его с бумажной основы. Для лучшего прилипания промокните декаль чистой тряпочкой.



VERSION A: A-4E, S/N 149996, U.S. Navy, VA-46  
 LCDR John Mc Cain  
 U.S.S. Forrestal, July 1969

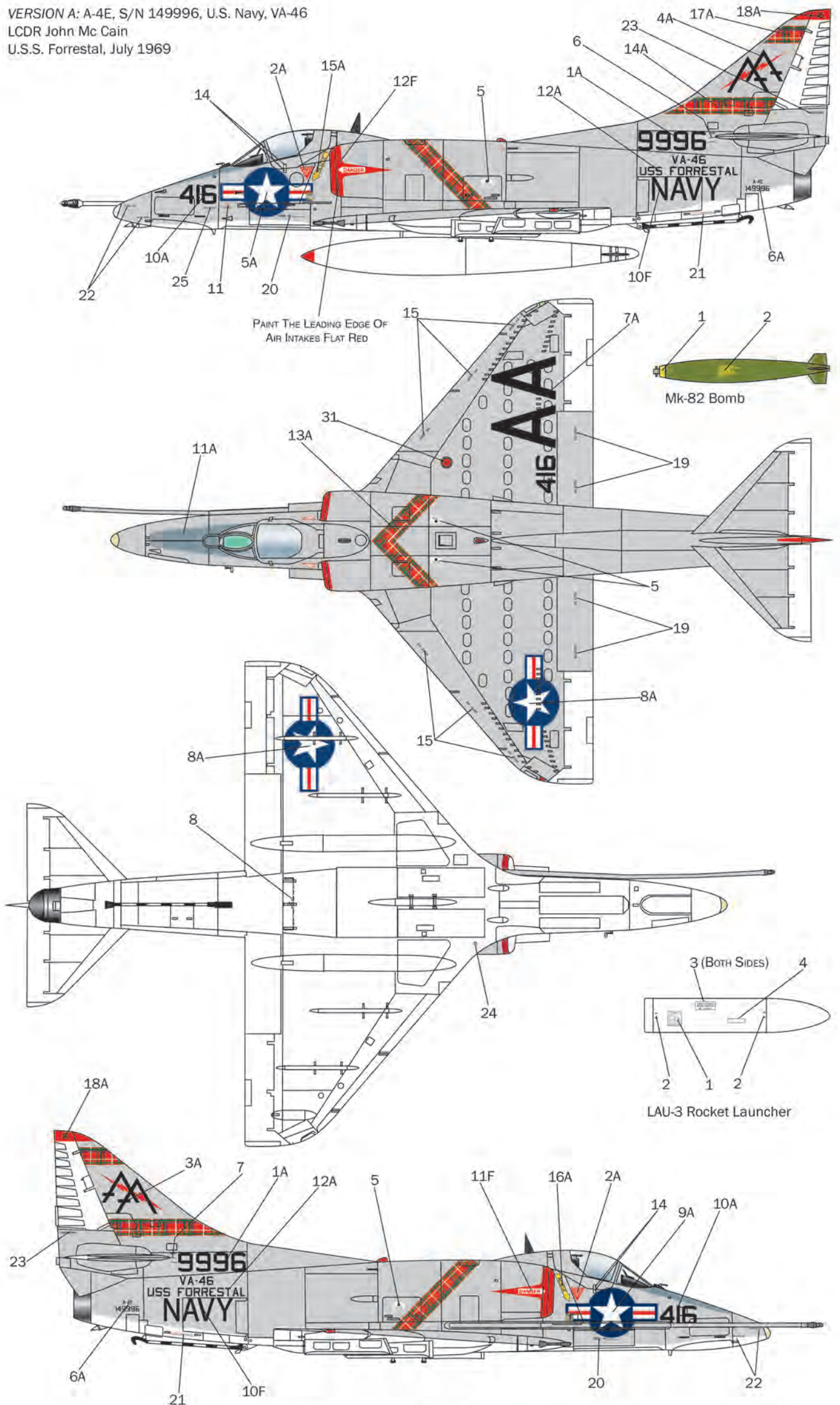

 Light Gull Gray F.S. 36440	 Flat White 4769AP F.S.37875	 Radome Tan F.S. 33613	 F Red 4606AP F.S. 31400	 F Gun Metal 4681AP F.S. 37200
---	---	--	---	---



VERSION B: A-4E, S/N 154183, U.S. Navy, VF-126 "Bandits"  
 S. Diego-Miramar MCAS, 1992

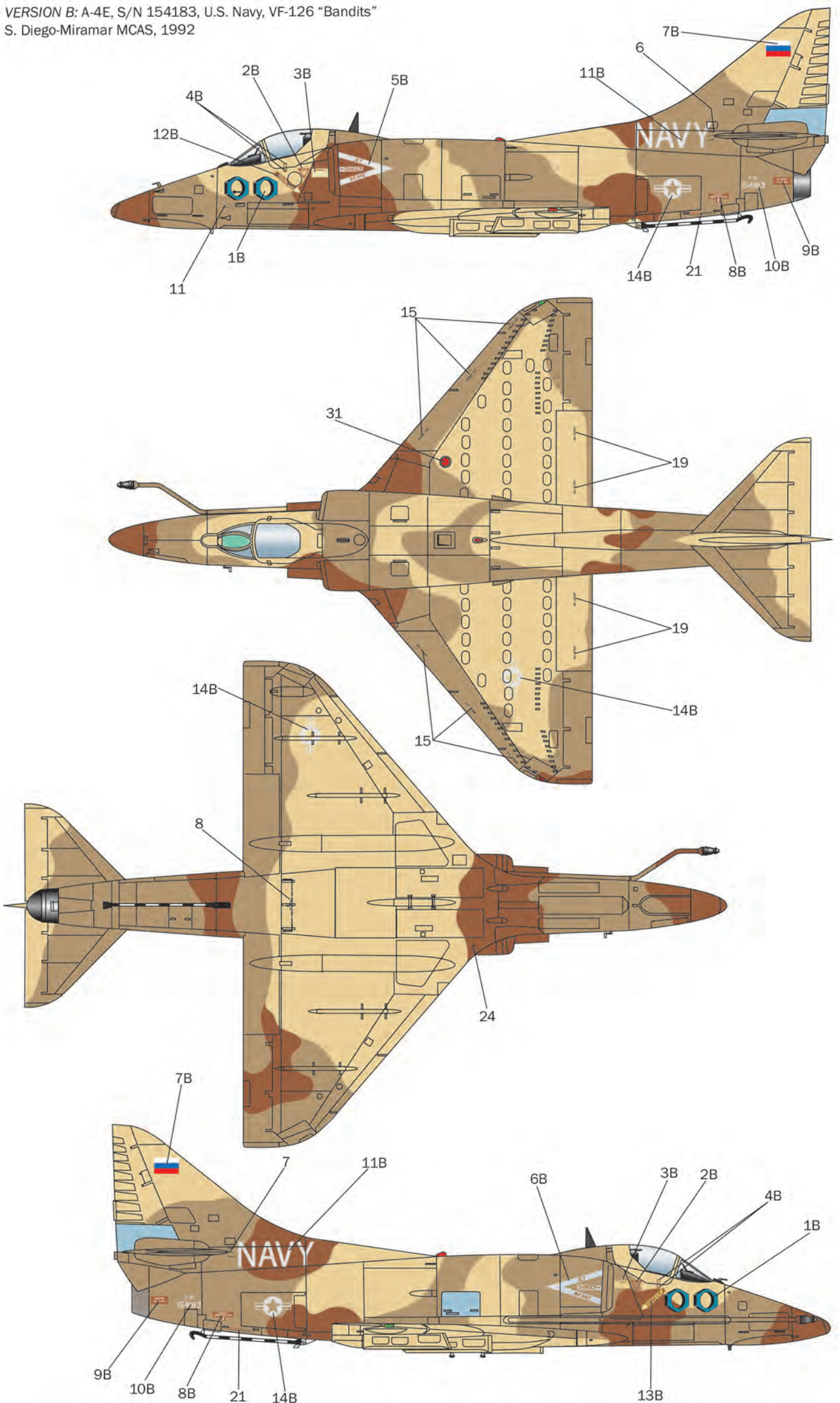

 Light Compass Ghost Gray F.S. 33531	 Middle Stone F.S. 33531	 F Dark Earth F.S. 30118	 F Dark Tan 4709AP F.S. 30219	 F Gun Metal 4681AP F.S. 37200
---	--	--	--	---



VERSION C: A-4E, S/N 154183, U.S. Navy, VF-126 "Bandits"  
 S. Diego-Miramar MCAS, december 1992

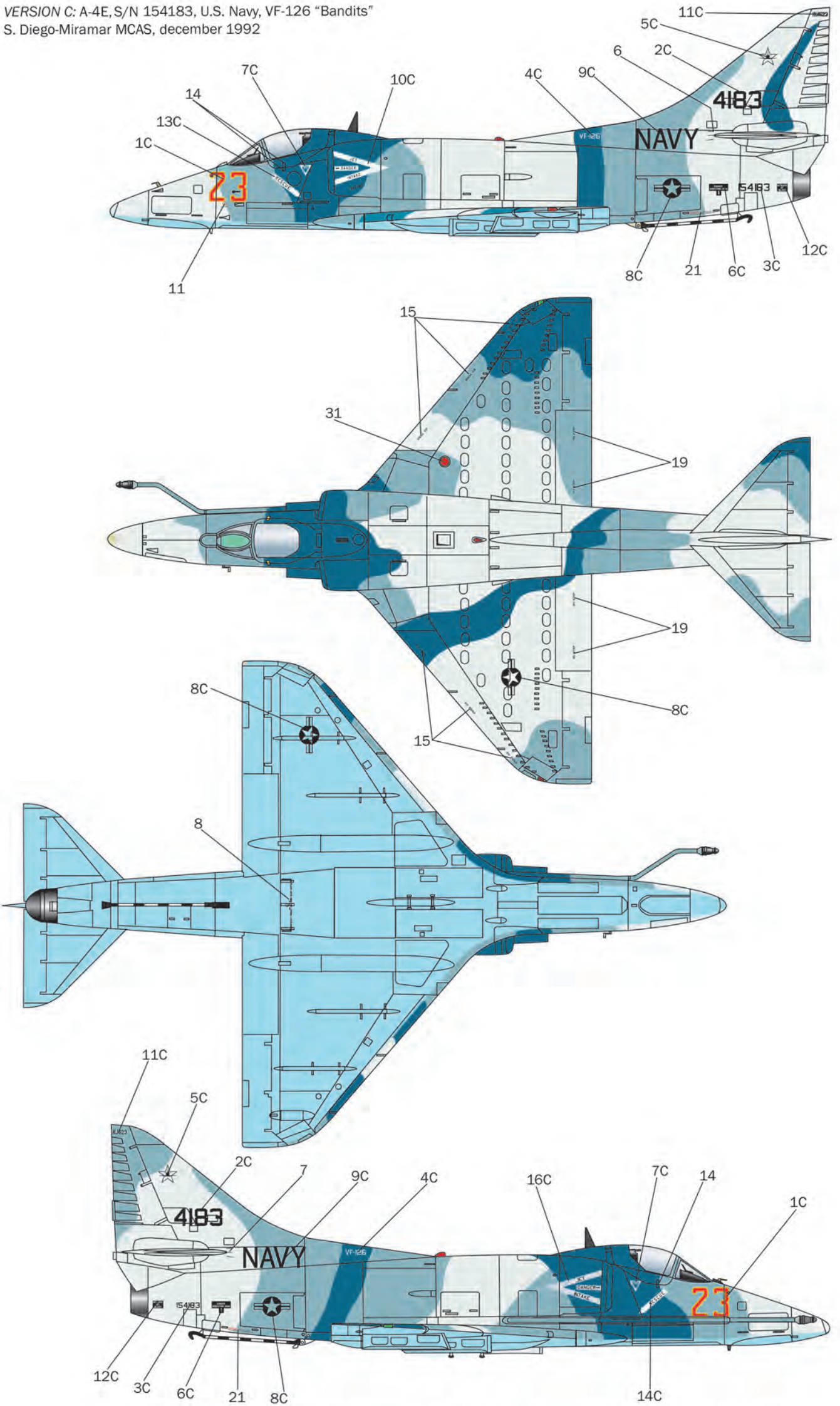

Light Gray 4765AP F.S. 36495	Air Superiority Blue F.S. 35450	Dark Gost Gray 4761AP F.S. 35237	Dark Blue F.S. 35109	F Gun Metal 4681AP F.S. 37200
------------------------------------	------------------------------------	--	-------------------------	-------------------------------------



VERSION D: A-4F, S/N 151087, U.S.M.C. VMA-124  
 NAS Memphis, Tennessee 1970.

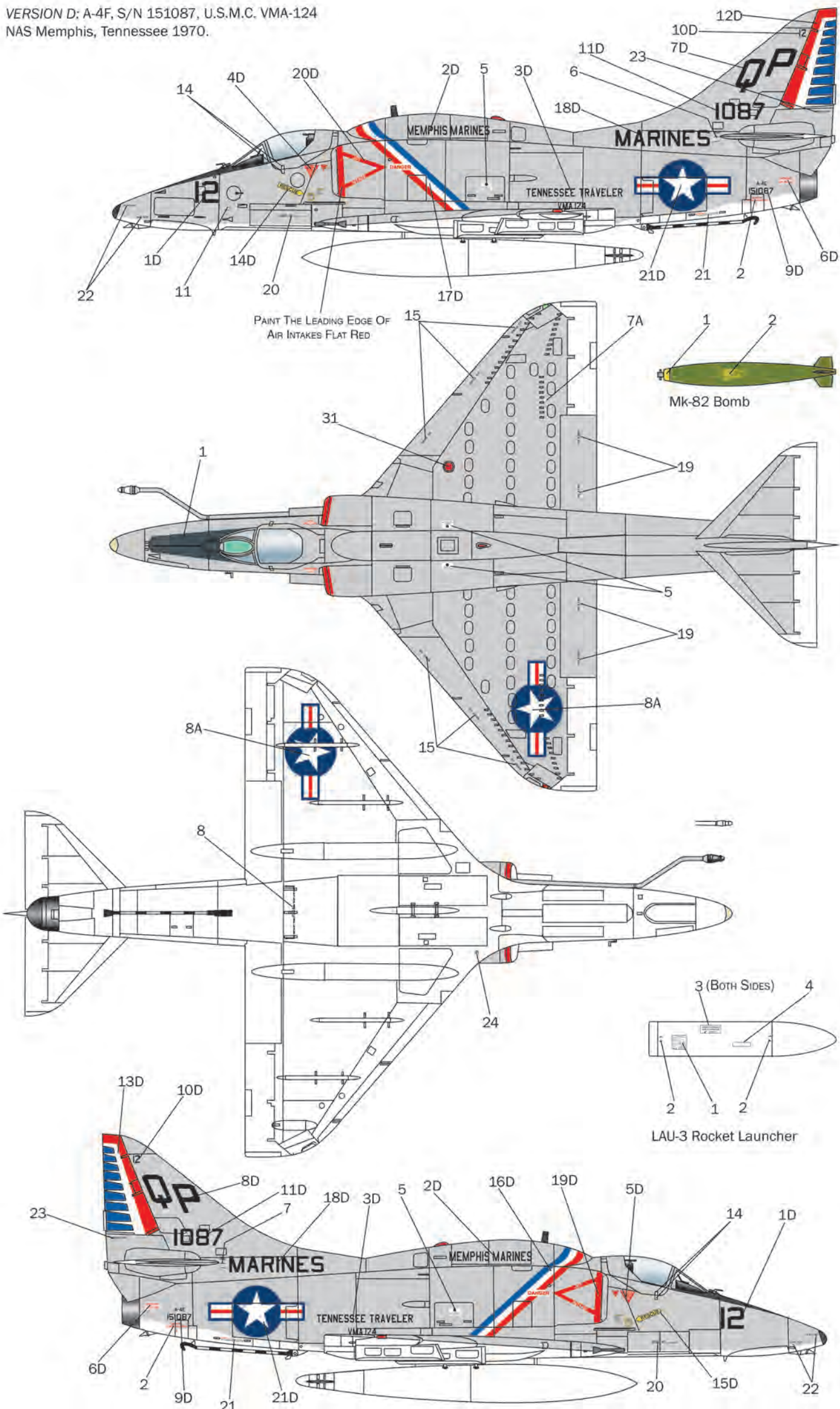

<table border="0"> <tr> <td style="background-color: #cccccc; width: 30px; height: 20px; display: inline-block;"></td> <td>Light Gull Gray F.S. 36440</td> <td style="vertical-align: top;"> <table border="0"> <tr> <td style="background-color: #ffffff; width: 30px; height: 20px; display: inline-block;"></td> <td>Flat White 4769AP F.S.37875</td> <td style="vertical-align: top;"> <table border="0"> <tr> <td style="background-color: #ff0000; width: 30px; height: 20px; display: inline-block;"></td> <td>F Red 4606AP F.S. 31400</td> <td style="vertical-align: top;"> <table border="0"> <tr> <td style="background-color: #000000; width: 30px; height: 20px; display: inline-block;"></td> <td>F Black 4768AP F.S. 37038</td> <td style="vertical-align: top;"> <table border="0"> <tr> <td style="background-color: #808080; width: 30px; height: 20px; display: inline-block;"></td> <td>F Gun Metal 4681AP F.S. 37200</td> </tr> </table> </td> </tr> </table> </td> </tr> </table> </td> </tr> </table> </td> </tr> </table>		Light Gull Gray F.S. 36440	<table border="0"> <tr> <td style="background-color: #ffffff; width: 30px; height: 20px; display: inline-block;"></td> <td>Flat White 4769AP F.S.37875</td> <td style="vertical-align: top;"> <table border="0"> <tr> <td style="background-color: #ff0000; width: 30px; height: 20px; display: inline-block;"></td> <td>F Red 4606AP F.S. 31400</td> <td style="vertical-align: top;"> <table border="0"> <tr> <td style="background-color: #000000; width: 30px; height: 20px; display: inline-block;"></td> <td>F Black 4768AP F.S. 37038</td> <td style="vertical-align: top;"> <table border="0"> <tr> <td style="background-color: #808080; width: 30px; height: 20px; display: inline-block;"></td> <td>F Gun Metal 4681AP F.S. 37200</td> </tr> </table> </td> </tr> </table> </td> </tr> </table> </td> </tr> </table>		Flat White 4769AP F.S.37875	<table border="0"> <tr> <td style="background-color: #ff0000; width: 30px; height: 20px; display: inline-block;"></td> <td>F Red 4606AP F.S. 31400</td> <td style="vertical-align: top;"> <table border="0"> <tr> <td style="background-color: #000000; width: 30px; height: 20px; display: inline-block;"></td> <td>F Black 4768AP F.S. 37038</td> <td style="vertical-align: top;"> <table border="0"> <tr> <td style="background-color: #808080; width: 30px; height: 20px; display: inline-block;"></td> <td>F Gun Metal 4681AP F.S. 37200</td> </tr> </table> </td> </tr> </table> </td> </tr> </table>		F Red 4606AP F.S. 31400	<table border="0"> <tr> <td style="background-color: #000000; width: 30px; height: 20px; display: inline-block;"></td> <td>F Black 4768AP F.S. 37038</td> <td style="vertical-align: top;"> <table border="0"> <tr> <td style="background-color: #808080; width: 30px; height: 20px; display: inline-block;"></td> <td>F Gun Metal 4681AP F.S. 37200</td> </tr> </table> </td> </tr> </table>		F Black 4768AP F.S. 37038	<table border="0"> <tr> <td style="background-color: #808080; width: 30px; height: 20px; display: inline-block;"></td> <td>F Gun Metal 4681AP F.S. 37200</td> </tr> </table>		F Gun Metal 4681AP F.S. 37200
	Light Gull Gray F.S. 36440	<table border="0"> <tr> <td style="background-color: #ffffff; width: 30px; height: 20px; display: inline-block;"></td> <td>Flat White 4769AP F.S.37875</td> <td style="vertical-align: top;"> <table border="0"> <tr> <td style="background-color: #ff0000; width: 30px; height: 20px; display: inline-block;"></td> <td>F Red 4606AP F.S. 31400</td> <td style="vertical-align: top;"> <table border="0"> <tr> <td style="background-color: #000000; width: 30px; height: 20px; display: inline-block;"></td> <td>F Black 4768AP F.S. 37038</td> <td style="vertical-align: top;"> <table border="0"> <tr> <td style="background-color: #808080; width: 30px; height: 20px; display: inline-block;"></td> <td>F Gun Metal 4681AP F.S. 37200</td> </tr> </table> </td> </tr> </table> </td> </tr> </table> </td> </tr> </table>		Flat White 4769AP F.S.37875	<table border="0"> <tr> <td style="background-color: #ff0000; width: 30px; height: 20px; display: inline-block;"></td> <td>F Red 4606AP F.S. 31400</td> <td style="vertical-align: top;"> <table border="0"> <tr> <td style="background-color: #000000; width: 30px; height: 20px; display: inline-block;"></td> <td>F Black 4768AP F.S. 37038</td> <td style="vertical-align: top;"> <table border="0"> <tr> <td style="background-color: #808080; width: 30px; height: 20px; display: inline-block;"></td> <td>F Gun Metal 4681AP F.S. 37200</td> </tr> </table> </td> </tr> </table> </td> </tr> </table>		F Red 4606AP F.S. 31400	<table border="0"> <tr> <td style="background-color: #000000; width: 30px; height: 20px; display: inline-block;"></td> <td>F Black 4768AP F.S. 37038</td> <td style="vertical-align: top;"> <table border="0"> <tr> <td style="background-color: #808080; width: 30px; height: 20px; display: inline-block;"></td> <td>F Gun Metal 4681AP F.S. 37200</td> </tr> </table> </td> </tr> </table>		F Black 4768AP F.S. 37038	<table border="0"> <tr> <td style="background-color: #808080; width: 30px; height: 20px; display: inline-block;"></td> <td>F Gun Metal 4681AP F.S. 37200</td> </tr> </table>		F Gun Metal 4681AP F.S. 37200	
	Flat White 4769AP F.S.37875	<table border="0"> <tr> <td style="background-color: #ff0000; width: 30px; height: 20px; display: inline-block;"></td> <td>F Red 4606AP F.S. 31400</td> <td style="vertical-align: top;"> <table border="0"> <tr> <td style="background-color: #000000; width: 30px; height: 20px; display: inline-block;"></td> <td>F Black 4768AP F.S. 37038</td> <td style="vertical-align: top;"> <table border="0"> <tr> <td style="background-color: #808080; width: 30px; height: 20px; display: inline-block;"></td> <td>F Gun Metal 4681AP F.S. 37200</td> </tr> </table> </td> </tr> </table> </td> </tr> </table>		F Red 4606AP F.S. 31400	<table border="0"> <tr> <td style="background-color: #000000; width: 30px; height: 20px; display: inline-block;"></td> <td>F Black 4768AP F.S. 37038</td> <td style="vertical-align: top;"> <table border="0"> <tr> <td style="background-color: #808080; width: 30px; height: 20px; display: inline-block;"></td> <td>F Gun Metal 4681AP F.S. 37200</td> </tr> </table> </td> </tr> </table>		F Black 4768AP F.S. 37038	<table border="0"> <tr> <td style="background-color: #808080; width: 30px; height: 20px; display: inline-block;"></td> <td>F Gun Metal 4681AP F.S. 37200</td> </tr> </table>		F Gun Metal 4681AP F.S. 37200				
	F Red 4606AP F.S. 31400	<table border="0"> <tr> <td style="background-color: #000000; width: 30px; height: 20px; display: inline-block;"></td> <td>F Black 4768AP F.S. 37038</td> <td style="vertical-align: top;"> <table border="0"> <tr> <td style="background-color: #808080; width: 30px; height: 20px; display: inline-block;"></td> <td>F Gun Metal 4681AP F.S. 37200</td> </tr> </table> </td> </tr> </table>		F Black 4768AP F.S. 37038	<table border="0"> <tr> <td style="background-color: #808080; width: 30px; height: 20px; display: inline-block;"></td> <td>F Gun Metal 4681AP F.S. 37200</td> </tr> </table>		F Gun Metal 4681AP F.S. 37200							
	F Black 4768AP F.S. 37038	<table border="0"> <tr> <td style="background-color: #808080; width: 30px; height: 20px; display: inline-block;"></td> <td>F Gun Metal 4681AP F.S. 37200</td> </tr> </table>		F Gun Metal 4681AP F.S. 37200										
	F Gun Metal 4681AP F.S. 37200													



VERSION A: A-4F, Israeli Air Force, "Knight of the North"  
 Hatzor AB, 1970.

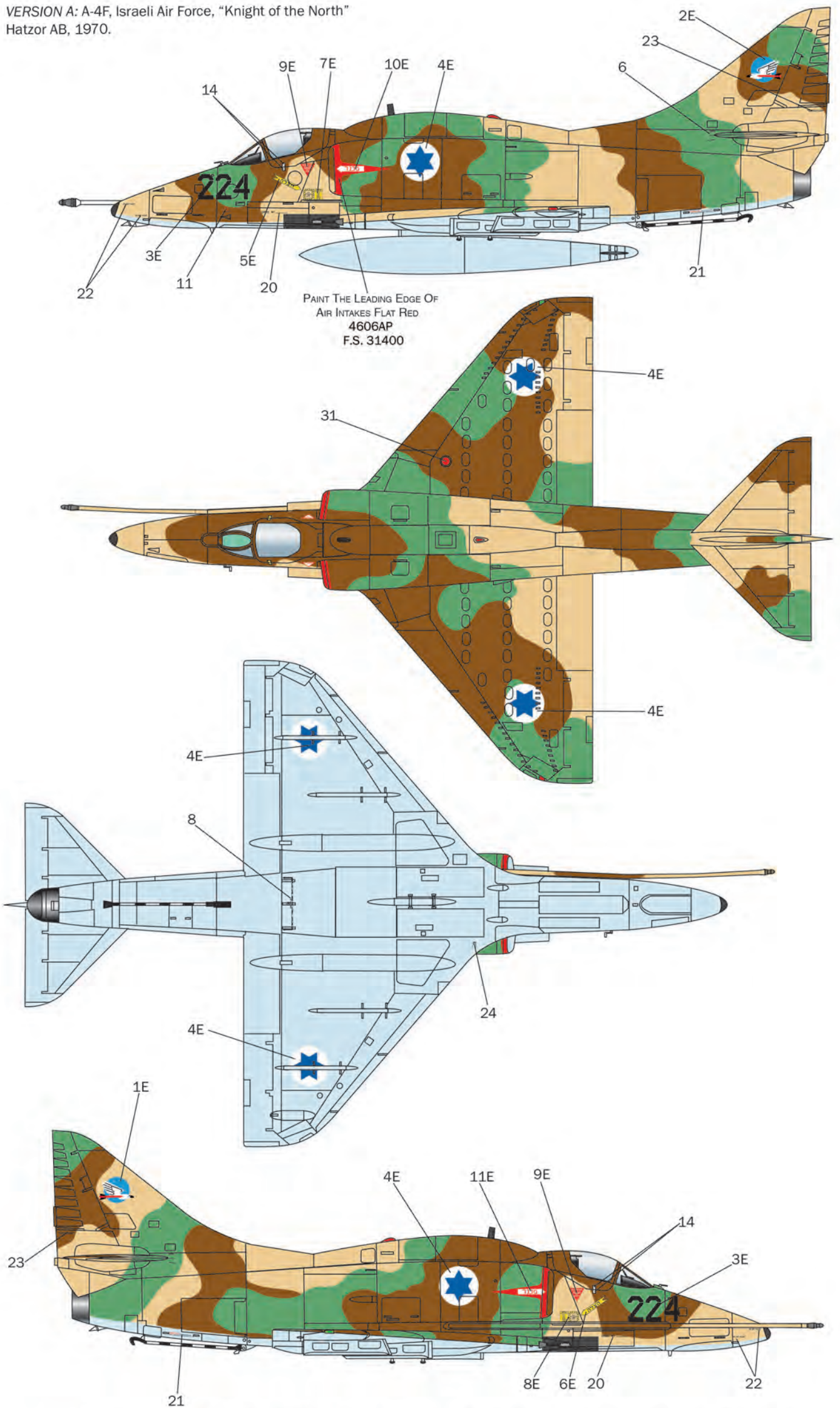

 F Sand	 F Dark Tan	 F Light Green	 F Light Blue	 F Black	 F Gun Metal
F.S. 33531	F.S. 4709AP F.S. 30219	F.S. 34227	F.S. 35622	F.S. 4768AP F.S. 37038	F.S. 4681AP F.S. 37200



VERSION F: Douglas A-4G Skyhawk, BuNo 154906  
 Royal Australian Navy, 805th Squadron  
 HMAS Melbourne 1980

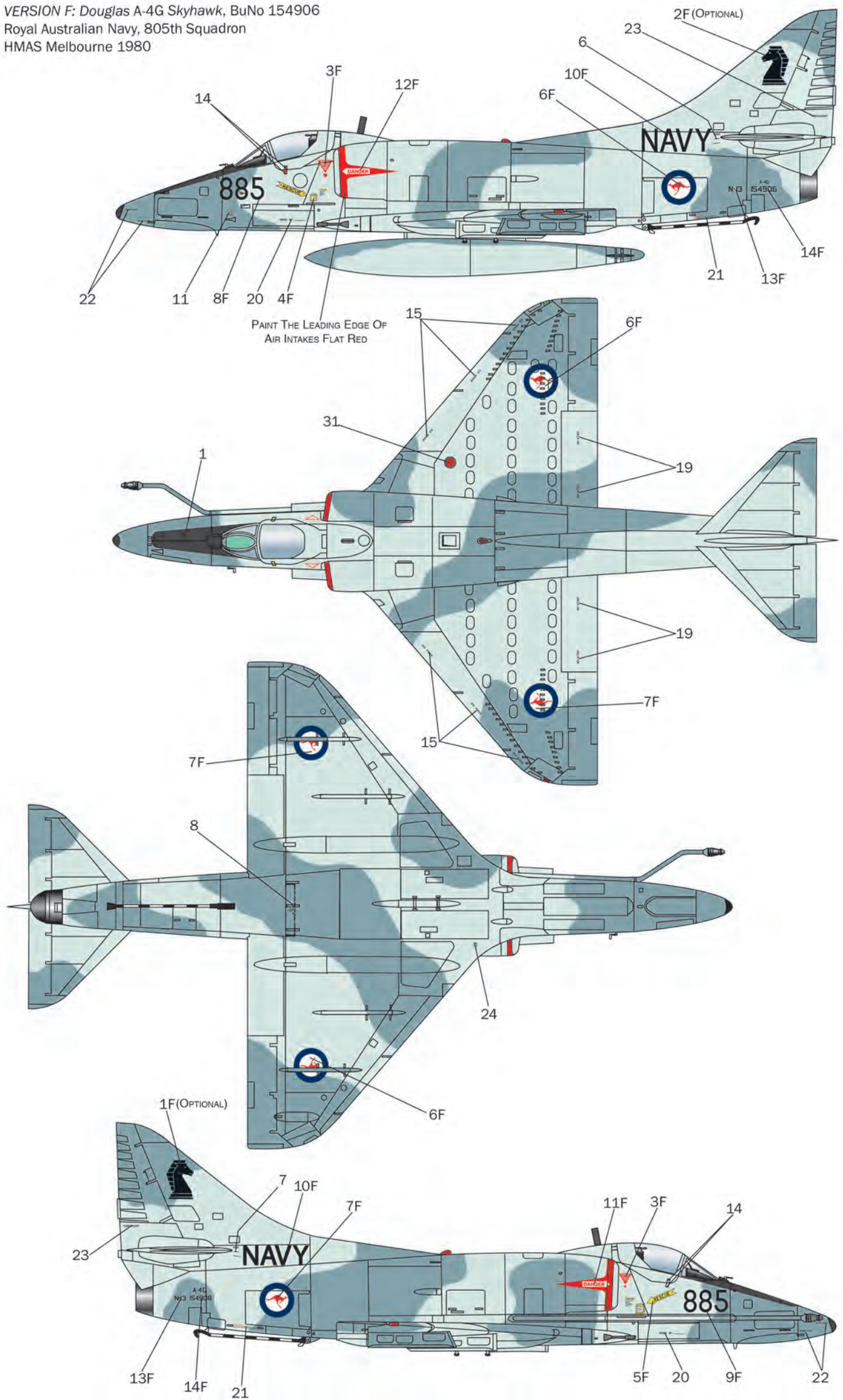

PAINT THE LEADING EDGE OF AIR INTAKES FLAT RED

 F Light Blue F.S. 35622	 F Dark Ghost Gray 4761AP F.S. 35237	 F Red 4606AP F.S. 31400	 F Black 4768AP F.S. 37038	 F Gun Metal 4681AP F.S. 37200
--	---	---	--	---