

| | | |
|--|-----------------------------|----------------------------|
| ITEM 46020 | PARTS NAME #00000000 | PREPARED BY: A.AOKI |
| NAME QDT Trail Master REWORKING | Unpacking | |

Protective board

Thin paper

Transparent window (top)

Transparent window (side)

Cut tape

Open this side

Be careful not to lose bag with instructions manual.

Bag with instructions manual

Thin paper is for protecting window and will be reused (do NOT throw out).

!
IMPORTANT:
Number on bag corresponds with band frequency number. Make sure not to misplace.

Remove Trail Master from packaging with Styrofoam still attached.

ITEM **46020**

PARTS NAME #00000000

PREPARED BY: **A.AOKI**

NAME **QDT Trail Master REWORKING**

Removing the motor

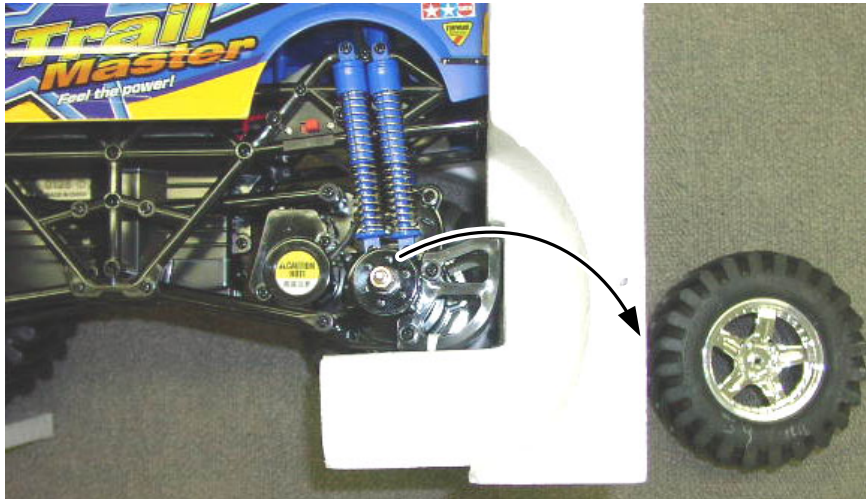

Use box wrench to remove central nut of right-rear wheel. Remove wheel.

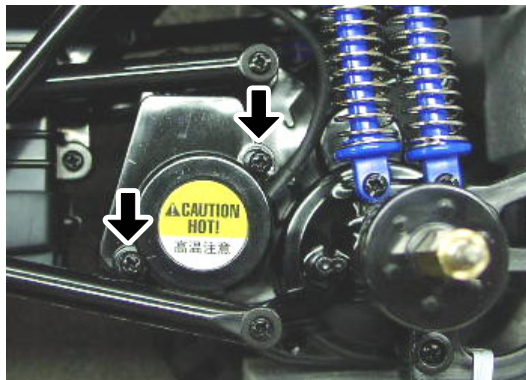

Take off motor cover by removing screws marked by arrows.

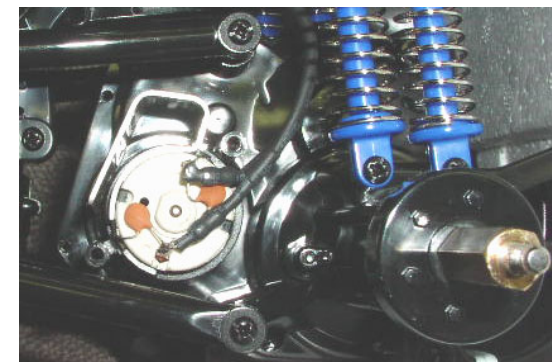

Take out motor by pulling straight back.

| | | |
|--|-----------------------------|----------------------------|
| ITEM 46020 | PARTS NAME #00000000 | PREPARED BY: A.AOKI |
| NAME QDT Trail Master REWORKING | Cable treatment | |

Cut cable at this line (1cm above from point where two cables join into one)

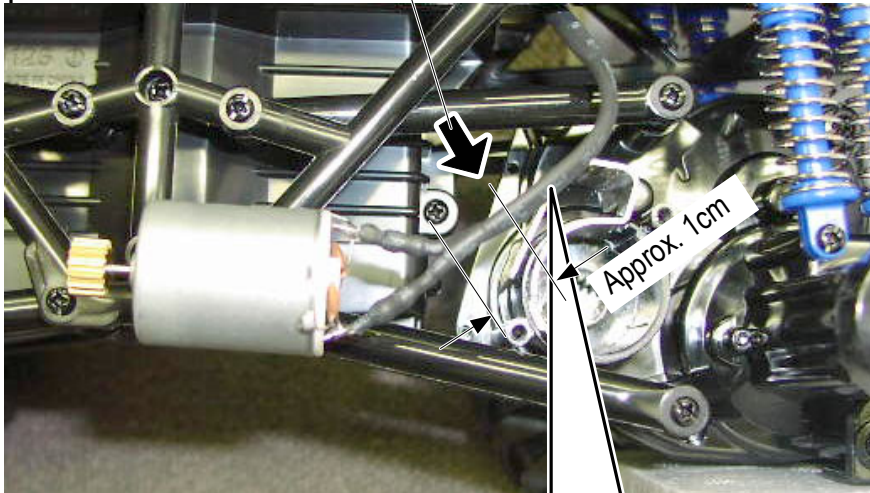

Treat the replacement motor cable as shown.

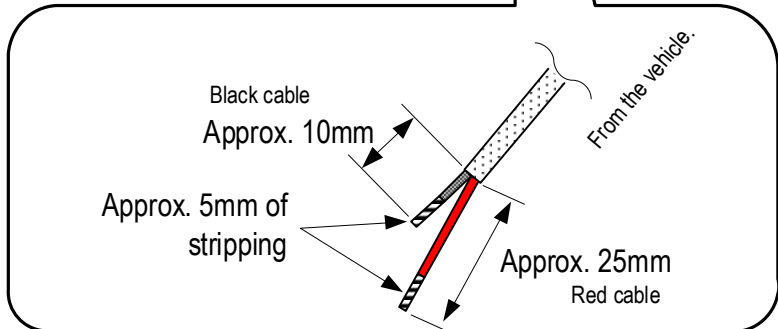
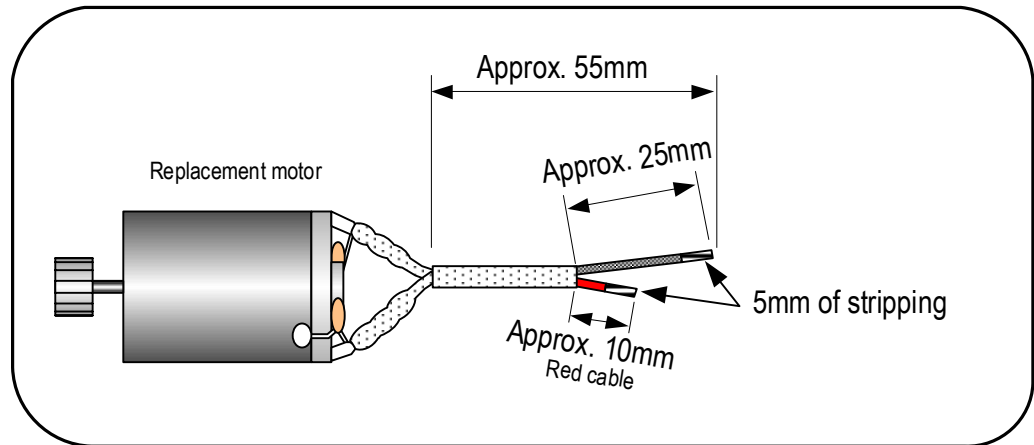

Strip the sleeve off from the cable as shown.

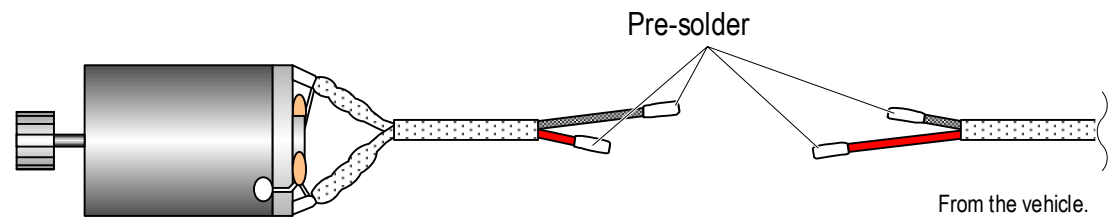

ITEM **46020**

PARTS NAME #00000000

PREPARED BY: **A.AOKI**

NAME **QDT Trail Master REWORKING**

Connecting the cables

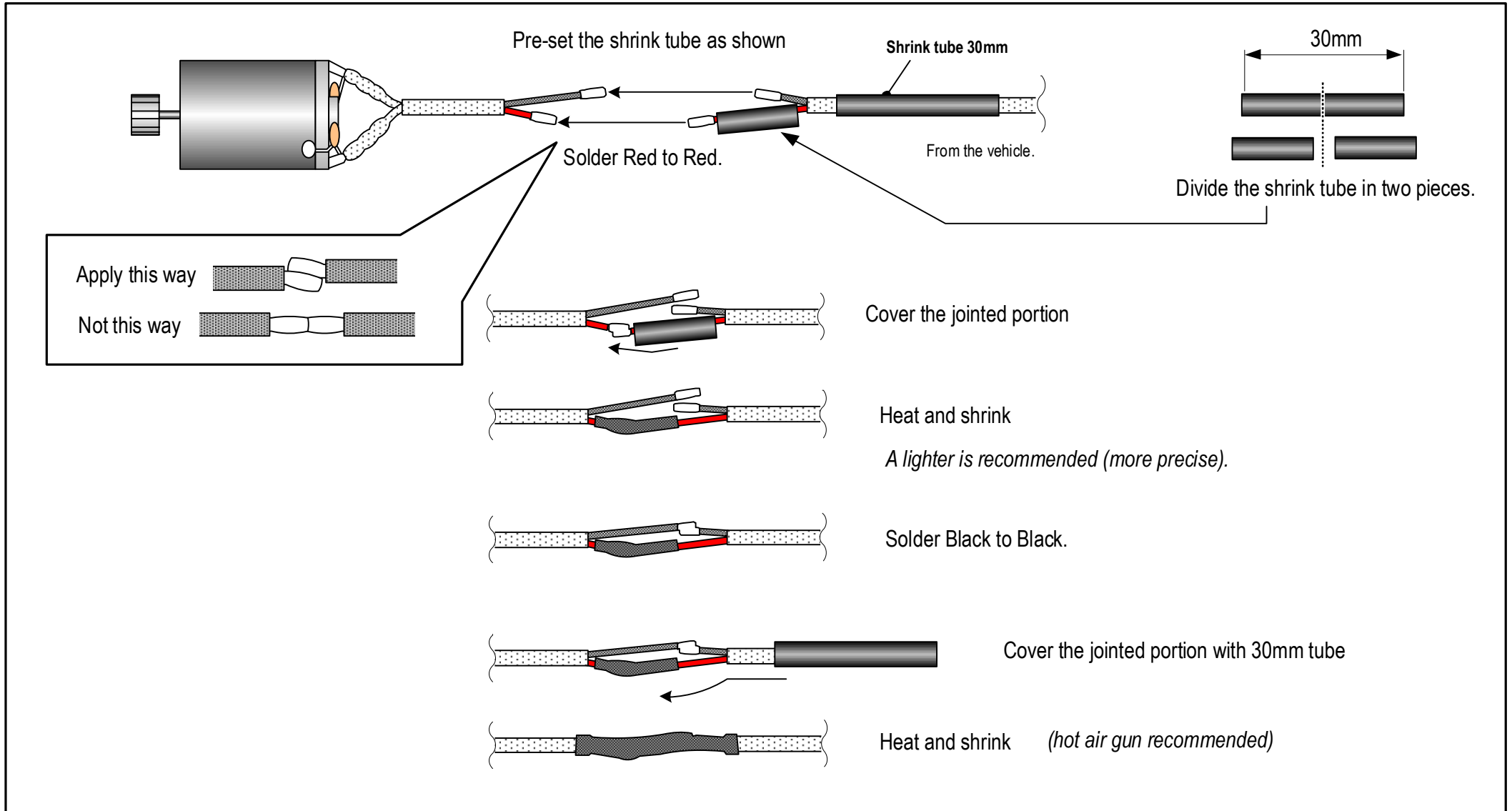

| | | |
|--|----------------------|----------------------------------|
| ITEM 46020 | PARTS NAME #00000000 | PREPARED BY: A.AOKI |
| NAME QDT Trail Master REWORKING | | Attaching the motor, and packing |

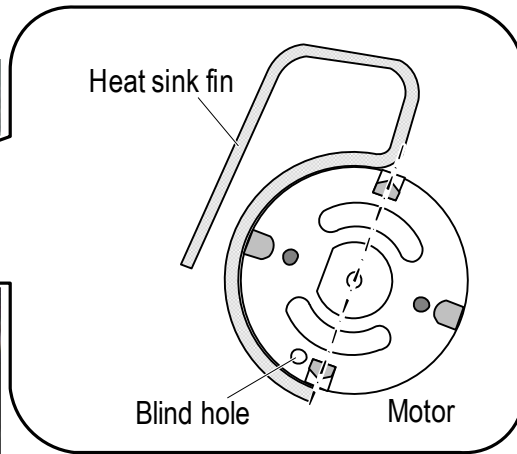
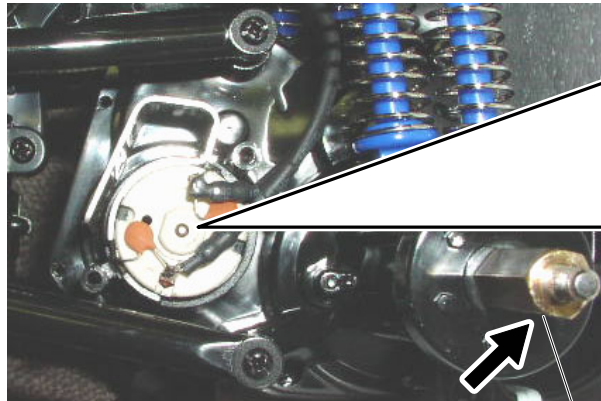

Install the motor, aligning openings as shown in illustration.

Turn axle so that motor pinion fits properly.



Axle

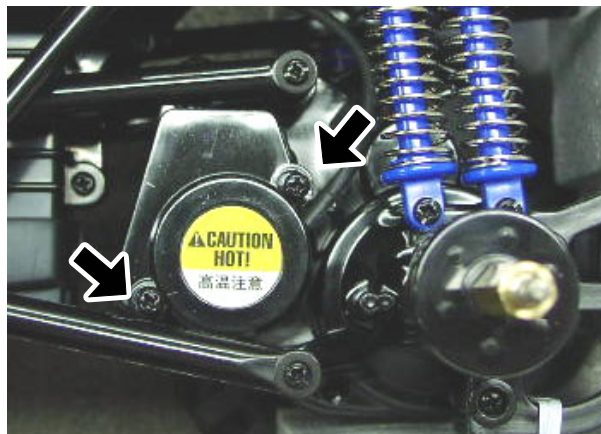

Attach motor cover with 2 screws.

Please confirm that there are no gaps between motor cover and gear case.

Attach the tire

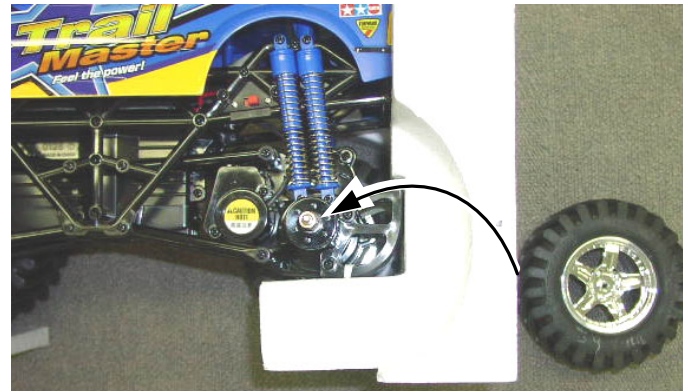

| | | |
|--|-----------------------------|----------------------------|
| ITEM 46020 | PARTS NAME #00000000 | PREPARED BY: A.AOKI |
| NAME QDT Trail Master REWORKING | Inspection | |

Inspection (before packaging, keep mounted on Styrofoam)

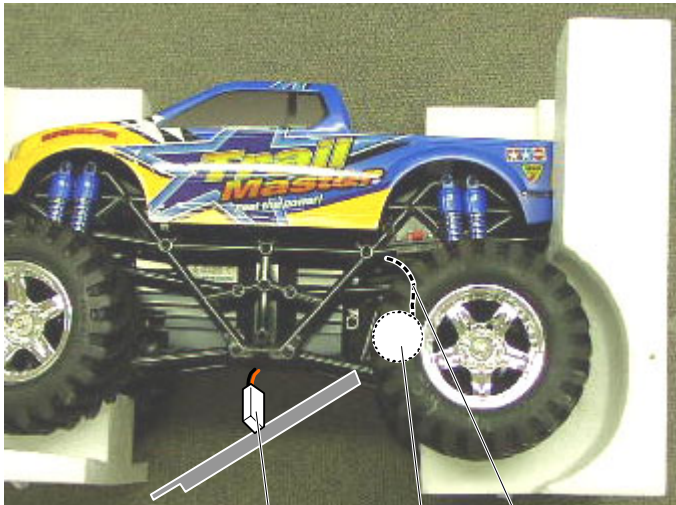

motor
wiring
Connect battery to this plug

Insert battery on underside of chassis, operate transmitter and check rotation of back wheels.

Grasp wiring and shake (check that wires are properly soldered.)

(Have transmitter bands 1-6, and battery ready)

| | | |
|--|----------------------|----------------------------|
| ITEM 46020 | PARTS NAME #00000000 | PREPARED BY: A.AOKI |
| NAME QDT Trail Master REWORKING | Repacking | |

Return the Trail Master and instruction manual to the package.

Please do not forget to re-pack instruction manual bag.

Make sure parts do not come loose from Styrofoam frame by inserting into box sideways, in the direction of the arrow.

Make sure frequency band number written on Trail Master corresponds with band number written on instruction manual and band number sticker on the box.



Sticker (denotes band number)

Transparent window (top)

Transparent window (side)

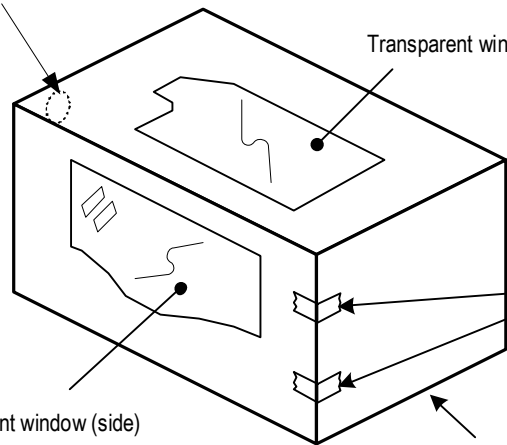

Fasten two areas with scotch (transparent) tape.

Insert through this side

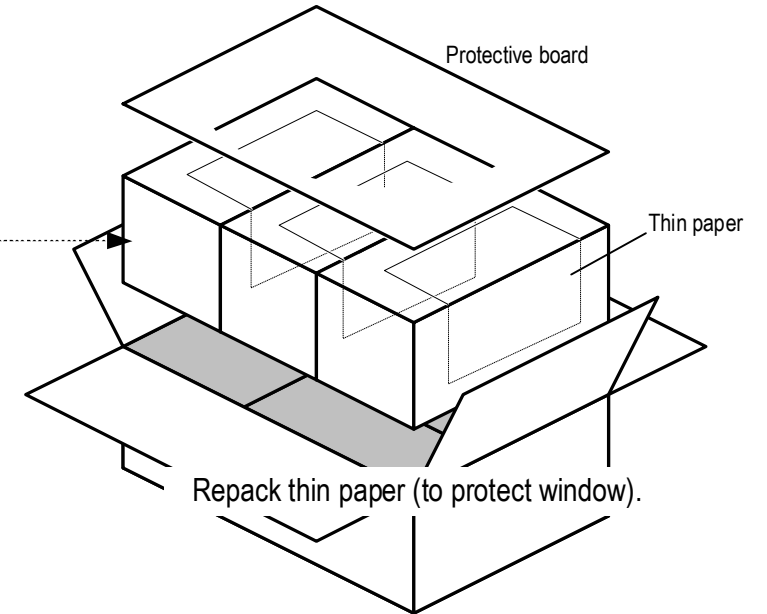

Repack thin paper (to protect window).

Re-cover with protective board and close box. Seal lid of package shut with carton sealing tape.