

M48A3 PATTON

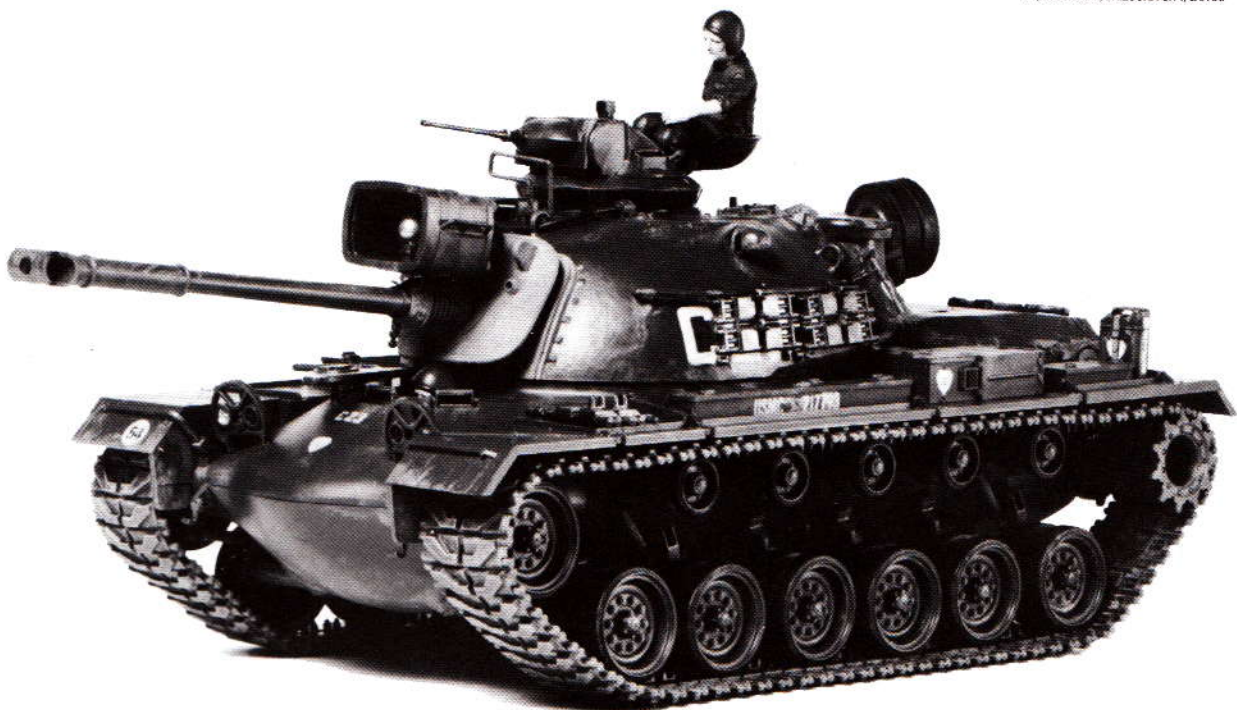

Design of the M48 series of medium tanks commenced in October 1950, with the Chrysler Corporation commissioned to do the design work and provide six prototypes. Due to the Korean war, production of the M48 was authorized prior to the completion of any prototype or testing. Ford and General Motors were awarded production contracts, in addition to Chrysler, and the first M48 was delivered in early 1953. Numerous technical problems with the new tank delayed its deployment in significant numbers until 1958. There are numerous variations and modifications of the M48 in existence all over the world today, and this kit depicts an M48A3 "Patton" as it appeared during the Viet Nam conflict when employed by the U.S. Forces. Using a cast elliptical hull which has high structural rigidity and excellent ballistic protection, this 47.5 ton tank has proven its worth in the field of combat against like opposition. The major improvement of the M48 over the M47 was the superior shape of the "Turtleback" cast steel turret, which provided a greater internal volume and much better ballistic protection. Armed with a 90mm M41 gun and one 7.62 coaxial machine gun and a 12.7 machine gun in the commanders cupola, and powered by a Continental V-12 AV-1790 petrol engine of 865 hp, this fine tank has a top road speed of 48 km/h. It is crewed by a Commander, Gunner, Radio operator/loader and a driver. The M48 series of medium tanks is or has been used by a great number of nations around the world, and is ex-

pected to remain a first line battle tank for many years to come.

The A3 series of the M-48 was the first to introduce the new AVDS-1790-2 diesel engine, which was a major improvement, and since its introduction many of the earlier Pattons have also been retrofitted with it. When used in Viet Nam, secondary armament was often boosted by adding a .50 calibre machine gun above the cupola; a 7.62 mm machine gun in front of the loaders hatch, and another 7.62mm MG in the mantlet in lieu of the telescopic sight. Early in its production the M-48 was fitted with a snorkeling kit which enables it to ford water obstacles up to 4.1 meters in depth. The M-48A3 uses a coincidence-type range finder for sighting its main 90mm gun. Range data from this sight is fed into a ballistic computer for very accurate and speedy target acquisition. Maximum road speed of the M-48A3 was 48km/h. Maximum range was 460 km, and the maximum road gradient was 60%. The A3 carried 62 rounds of 90mm ammunition, and up to 5900 rounds for the 7.62 MG's. The A-3 model can be seen with either 3 or 5 wheel track bogies, and the majority used in Viet Nam had five bogies, due to the jungle type of terrain encountered. Tank crew members often built up the sides of the turret with extra padding and equipment for additional protection from hostile fire. A great many of the existing M-48 tanks around the world are now being up graded to M-60 standards with the addition of the 105 mm gun in place of the 90mm main unit.

Im Oktober 1950 wurde die Chrysler Corporation beauftragt, Entwürfe für die M48 Serie und sechs Prototypen herzustellen. Durch den Korea-Krieg erhielten ausser Chrysler, Ford und General Motors Produktionsaufträge und der erste M48 konnte Anfangs 1953 ausgeliefert werden. Verschiedene technische Probleme mit dem neuen Tank verzögerten die Herstellung grösserer Mengen bis 1958. Es gibt verschiedene Abarten und Verbesserungen des M48 heute auf der ganzen Welt.

Dieser Kit zeigt den M48A3 "Patton," wie er in Vietnam eingesetzt wurde. Die gegossene Wanne hat eine strukturelle Starrheit und Härte mit hervorragendem Schutz. Gegenüber gleichstarken Gegnern zeigt dieser 47,5 to schwere Panzer seinen Wert.

Die Hauptverbesserung des M48 gegenüber dem M47 ist auch der gegossene Turm aus Stahl mit seinem grossen Innenraum und Schutzvermögen gegen feindliche Geschosse.

Die Bewaffnung besteht aus einer 90 mm M41 Kanone, einem koaxialen 7.62 MG und einem 12,7 MG auf der Kommandantenkuppel.

Der Antrieb erfolgt durch einen Continental V-12 AV-1790 Motor mit 865 PS. die Geschwindigkeit auf der Strasse liegt bei 48 km/Std. Die Crew besteht aus 4 Mann: Kommandant, Schütze, Fahrer und Funker/Ladeschütze.

Der M48 ist bei vielen Nationen auf der Welt im Dienst und wird der Kampfpanzer—in vorderster Linie—für viele Jahre bleiben.



READ BEFORE ASSEMBLY.
ERST LESEN — DANN BAUEN.

- ★ Study the instructions and photographs before commencing assembly.
- ★ You will need a sharp knife, a pair of tweezers, a pair of side cutters and an awl (1.2mm diam.)

🗨 This mark denotes the colour.
Overall painting shown on page 6.

★ Vor Beginn die Bauanleitung studieren und den Nummern nach die Elemente zusammensetzen.

★ Bauteile nicht vom Spritzling abbrechen, vorsichtig abschneiden oder abwicken, Teile vor Kleben zusammenhalten, auf genauen Sitz achten. Nicht zuviel Klebstoff verwenden. Kleine Teile hält man mit Pinzette fest.

★ Abziehbilder vorsichtig von der Unterlage im Wasser abschieben, auf richtigen Sitz achten und gut trocknen lassen.

🗨 Zeichen für Bemalung.

2

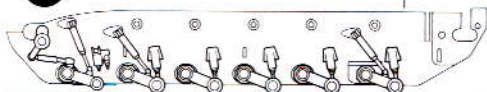

Adjust all suspension arms so they are parallel as shown.
Alle Schwingarme müssen auf gerader Ebene parallel stehen.

4

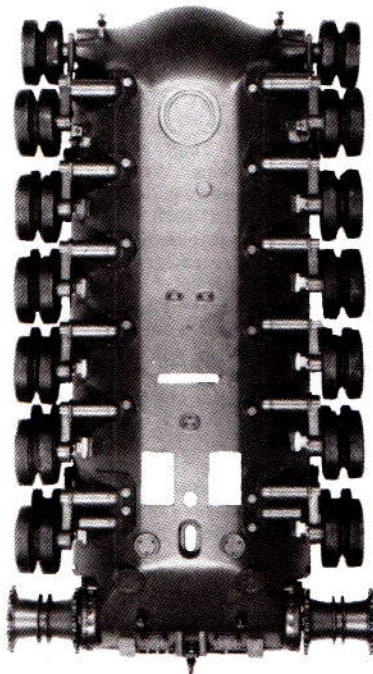

1 Wheels Räder

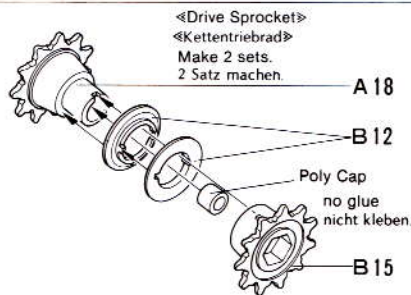
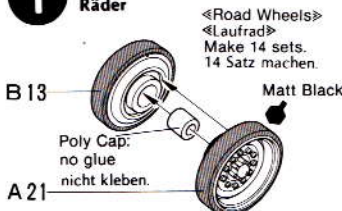

2 Suspension Arm Schwingarm

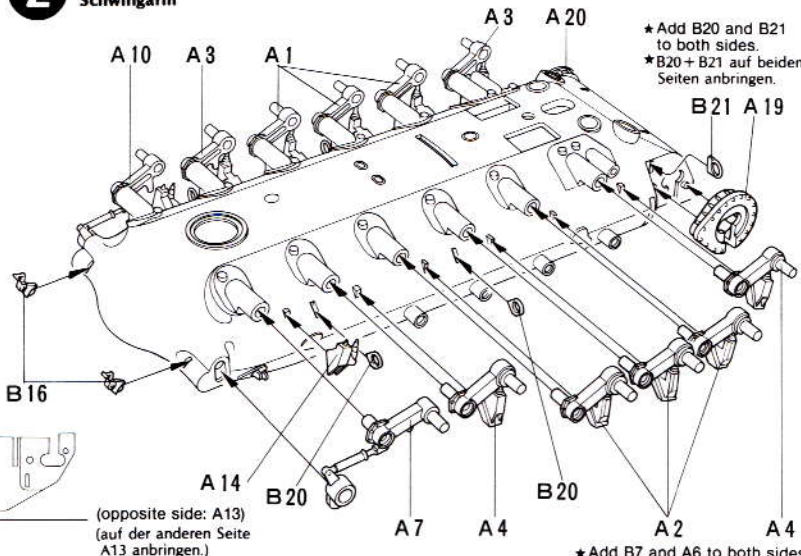

3 Assembly of Upper Wheels obere Kettenlaufräder

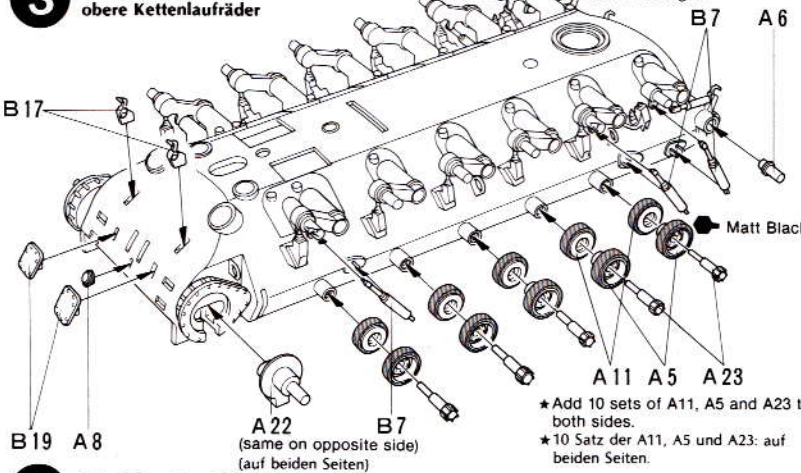

4 Attaching Road Wheels Einbau der Räder

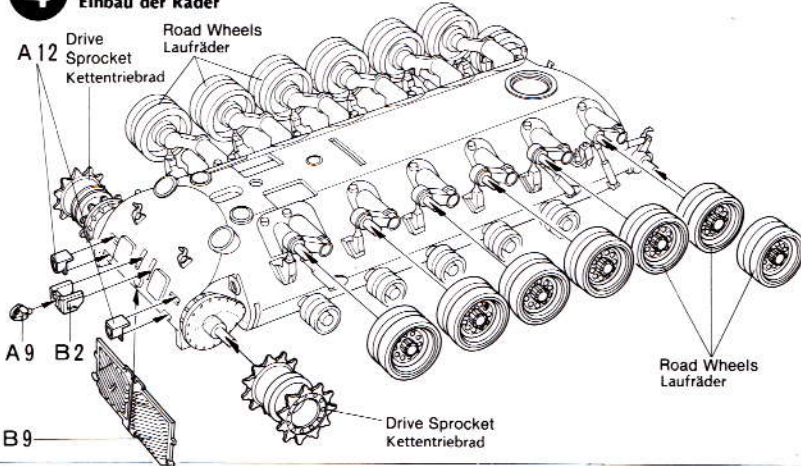

7 «Air Cleaners»
«Luftfilter»

«right»
«rechts»

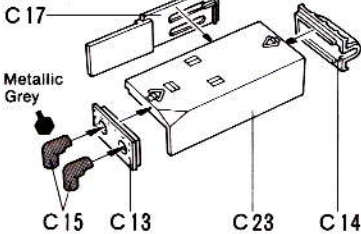

«left»
«links»

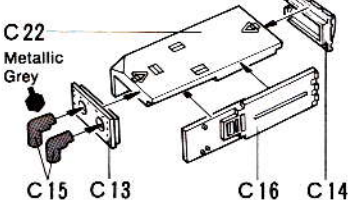

«Head Light: left»
«Scheinwerfer: links»

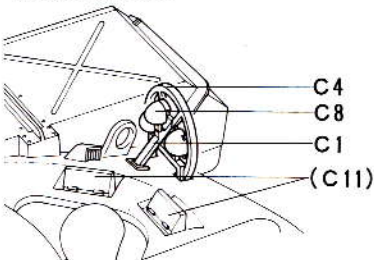

«Head Light: right»
«Scheinwerfer: rechts»

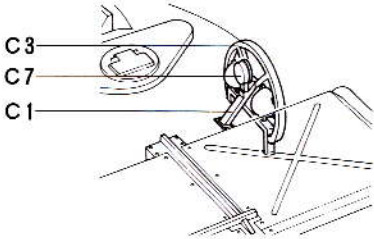

8

Cut transparent glass as shown below.
Transparent Teile wie angegeben schneiden.

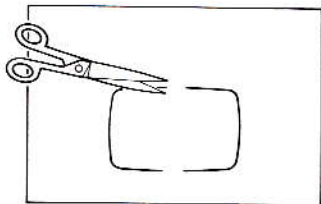

5

Inner Parts of Upper Body
Einbau der Innenteile

«Driver Figure»
«Fahrer Figur»

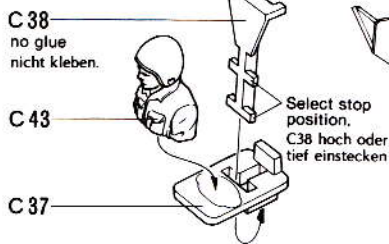

Poly Cap, large
(grosse)

See the diagram
at left.
Siehe links.

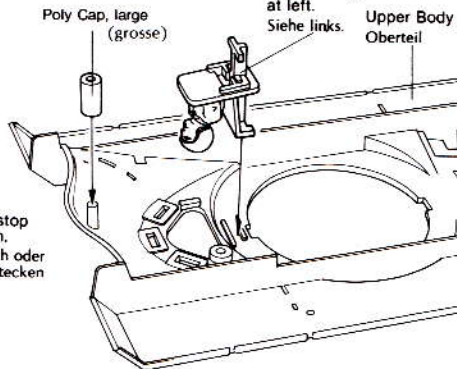

6

Attaching Fender Parts
Einbau der Kettenabdeckungteile

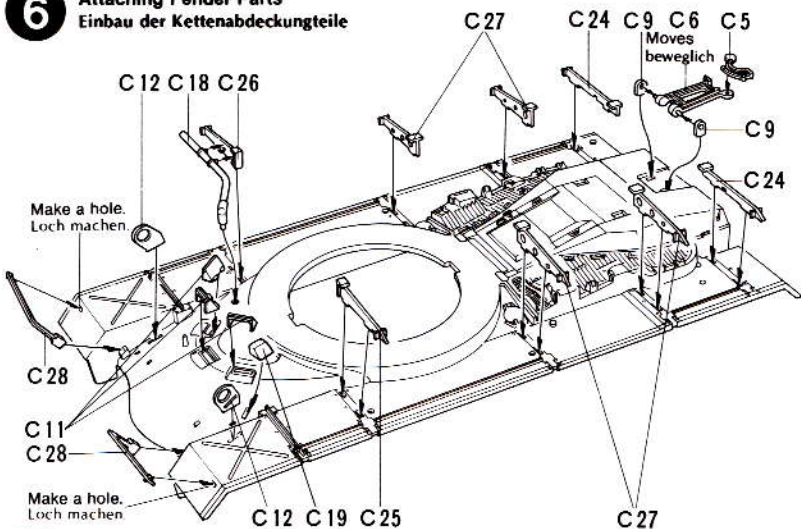

7

Adding Air Cleaner
Einbau der Luftfilter

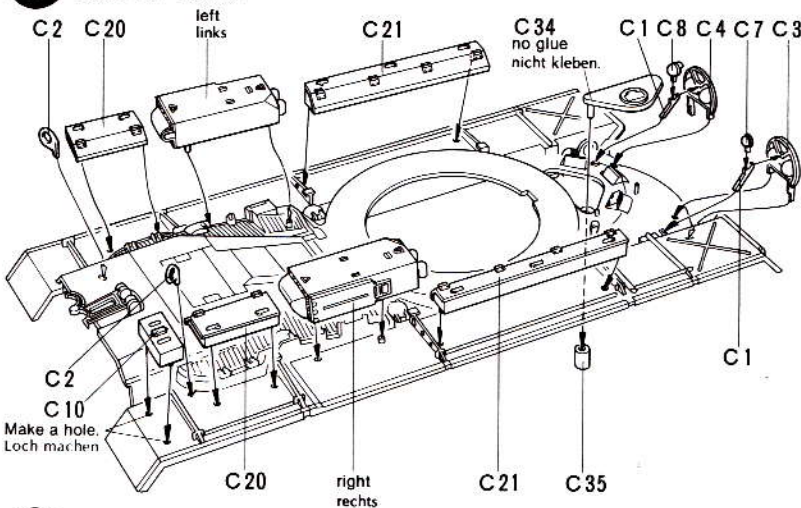

8

Gun-Barrel Construction
Kanonenrohrbau

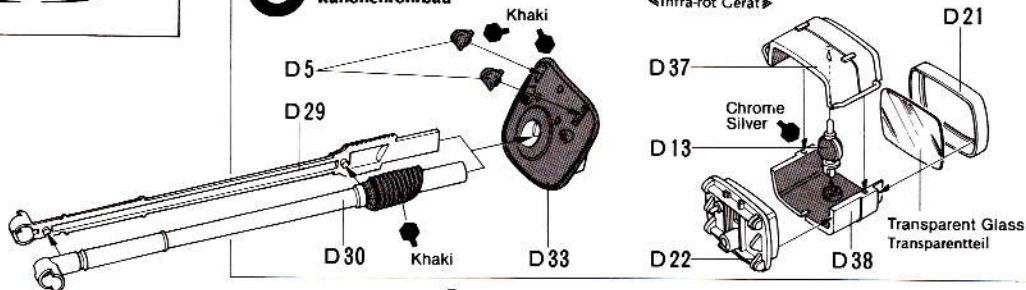

9

Firstly, make hand hold holes as shown.
Erst Löcher für Handgriffe bohren

«Left Side»
«Linke Seite»

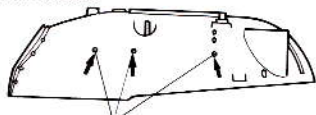

Bore 1.2mm diam. holes with an awl.
Löcher 1,2 mm mit Ahle bohren.

«Right Side»
«Rechte Seite»

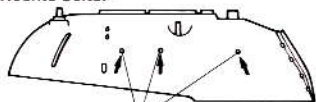

Bore 1.2mm diam. holes with an awl.
Löcher 1,2 mm mit Ahle bohren

11

«12.7mm MG»

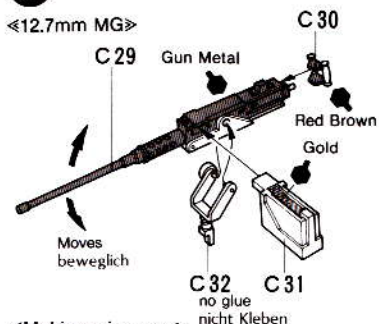

«Making wire rope»
«Schleppseil»

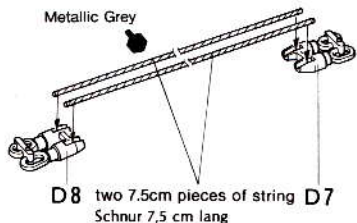

Apply cement to string to simulate rope.
Mit etwas Klebstoff auf der Schnur wird diese wie ein Seil aussehen.

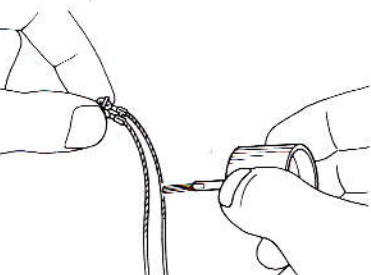

«Attached wire rope»
«Eingebautes Schleppseil»

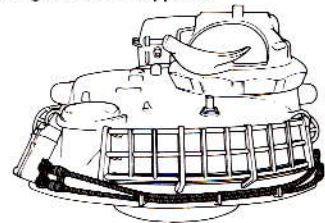
**9**

Mounting Gun-Barrel Einbau der Kanonenrohr

«Jerry Can A»
«Kanister A»

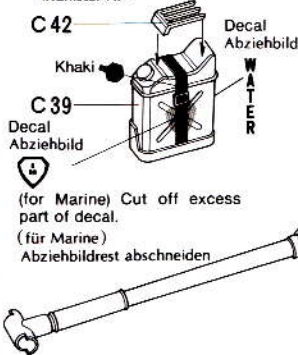

(for Marine) Cut off excess part of decal.
(für Marine) Abziehbildrest abschneiden

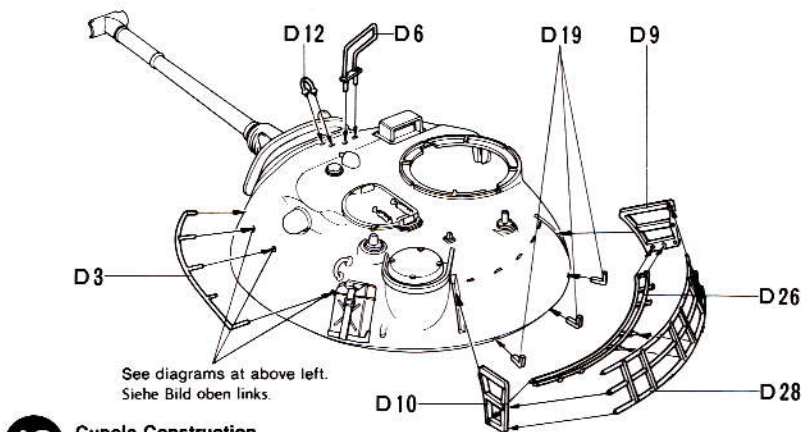

See diagrams at above left.
Siehe Bild oben links.

10

Cupola Construction Kuppelmontage

«Upper Part»
«Oberteil»

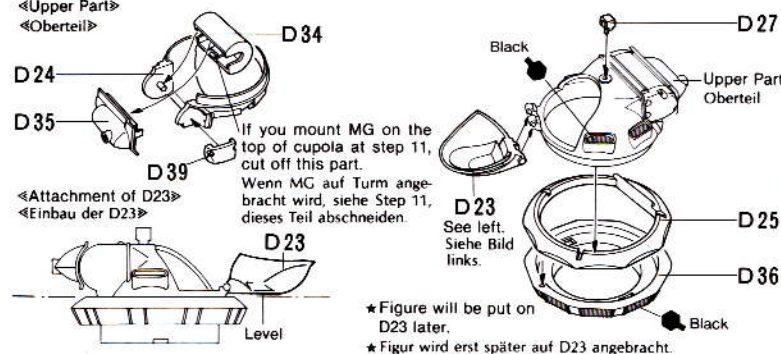

«Attachment of D23»
«Einbau der D23»

If you mount MG on the top of cupola at step 11, cut off this part.
Wenn MG auf Turm angebracht wird, siehe Step 11, dieses Teil abschneiden.

* Figure will be put on D23 later.

* Figur wird erst später auf D23 angebracht.

11

Mounting Cupola Einbau der Kuppel

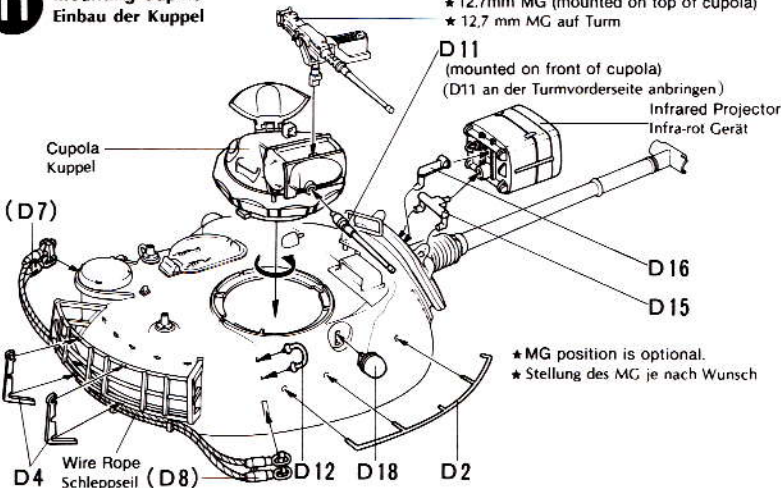

* 12.7mm MG (mounted on top of cupola)
* 12.7 mm MG auf Turm

D 11 (mounted on front of cupola)
(D11 an der Turmvorderseite anbringen)
Infrared Projector
Infra-rot Gerät

* MG position is optional.
* Stellung des MG je nach Wunsch

12 «Commander Figure»
«Kommandant Figur»



«Track Construction» Make 2 sets.
«Kettenmontage» 2 Satz machen.

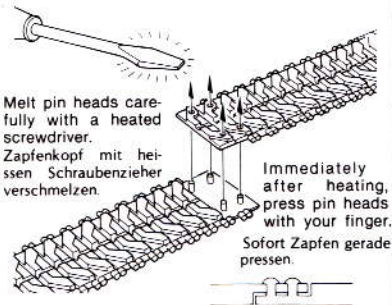

«Jerry Can B» Make 2 sets.
«Kanister B» 2 Satz machen.

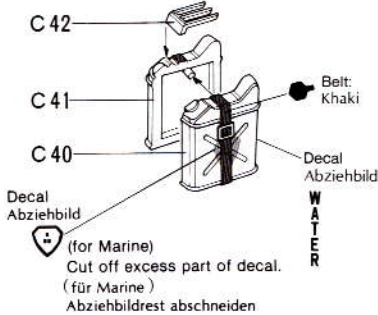

12 Final Assembly
Endmontage

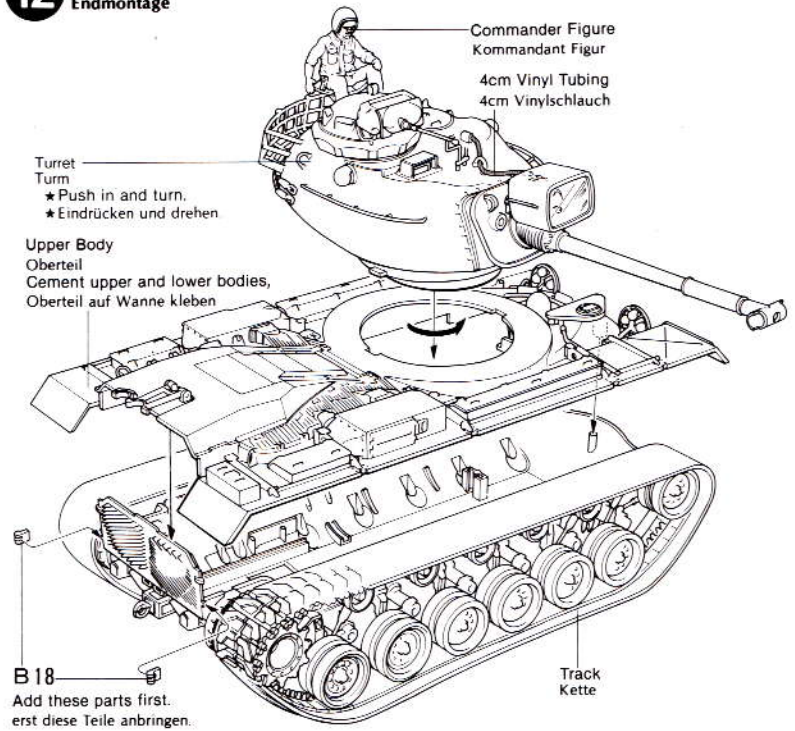

«Snockel»
«Schnorchelrohr»

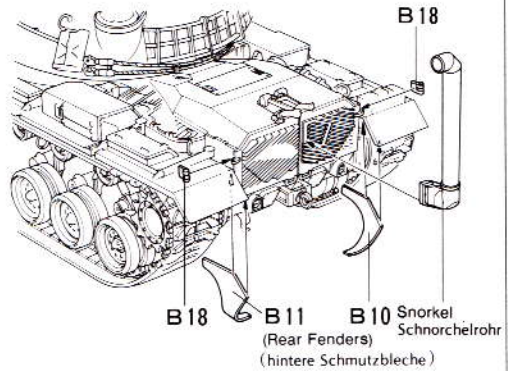
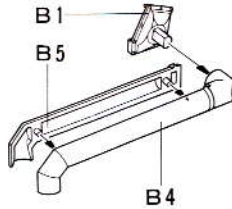

13 Accessory Parts
Zubehörteile

★ Position of accessory parts can vary. Shown below is an example. Use this as a guide and add parts to suit your tastes.
★ Die Zubehörteile wie unten gezeigt sind nur ein Beispiel und können je nach Wunsch angebracht werden.

Not used A15,16,17,C36

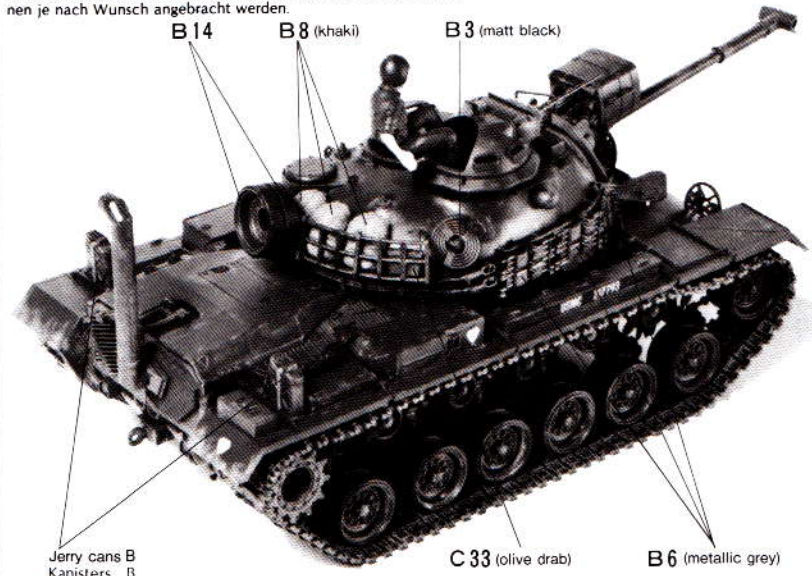

Tamiya Acrylic Paints
Need precise colour matching?
Try the new Tamiya acrylic paints. Engineered by modelers for modeler's use. The final cover for the finest modelers. Insist on Tamiya for perfect results.



TAMIYA COLOR CATALOGUE
The latest in cars, boats, tanks and ships. Motorized, radio controlled and museum quality models are all shown in full color in Tamiya's latest catalogue. At your nearest hobby supply house.

PAINTING



APPLYING DECALS

Standard colour of M48 is olive drab all over. Your model will, however, have greater realism if you give it the appearance of an original tank, i.e.: mudsplashed parts, soot dirtied exhaust pipes, bare iron surfaces where paint has been scratched and knocked. In addition, you can also add "Shark Mouth" referring to box side drawing.

Der Panzer M48 ist olive drab bemalt. Mit russgeschwärztem Auspuff und etwas verreckten Teilen wirkt das Modell eindrucksvoller.

«Required Colours»

«Benötigter Bemalung»

- Olive Drab
- Gun Metal
- Gold
- Chrome Silver
- Matt Black
- Flesh
- Khaki
- Dark Green

«U.S. Army's Marks»

IIACR	11th Armored Cavalry Regiment
I-TK2	2nd Tank Platoon, 1st Tank Company
9-2Δ77	2nd Tank Battalion, 77th Mechanized Regiment
B12	Tank 2 belonging to 1st Platoon, B Company

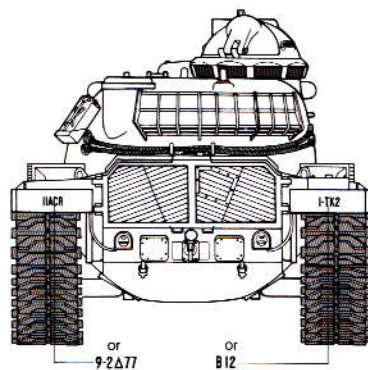
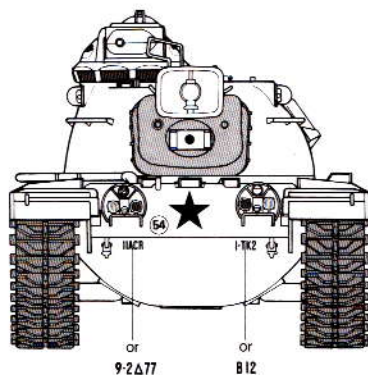

U.S. Marine's Marks

Some tanks wore this mark.
Einige Panzer trugen diese Zeichen.

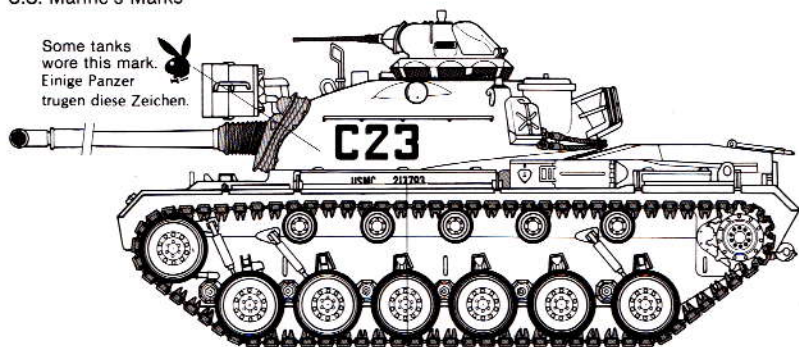

USMC 217793 or USMC 202078

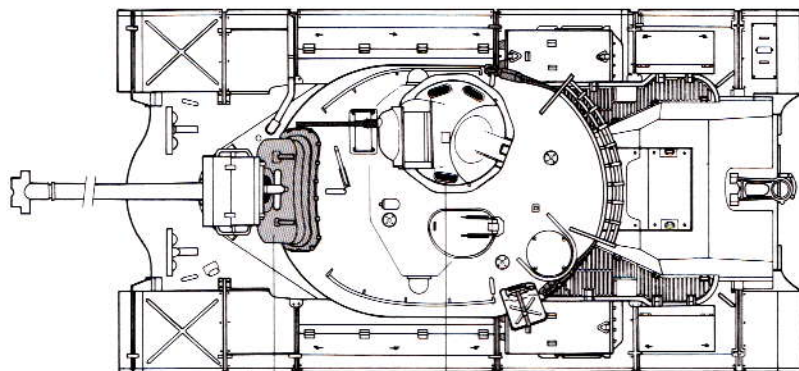

Khaki Black Chrome Silver

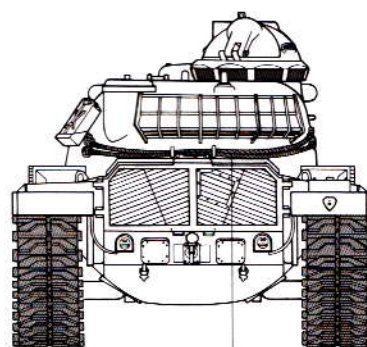
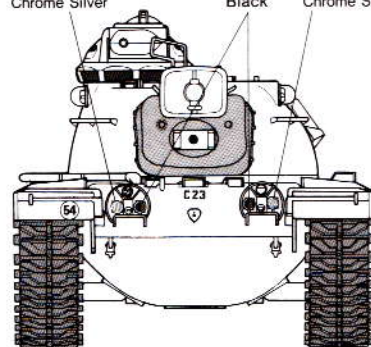

Metallic Grey

U.S. Army's Marks

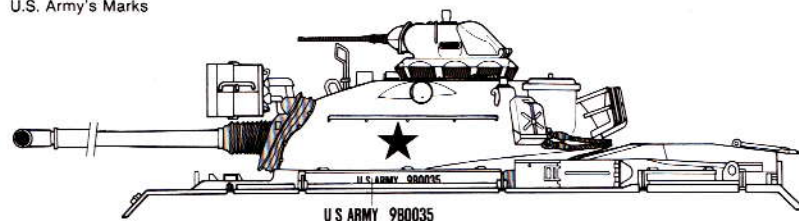

U.S. ARMY 980035

