

MARDER II TANK DESTROYER

Sd.kfz.131

1/35 MILITARY MINIATURE SERIES NO.60

KIT NO. MM-160



TAMIYA
TAMIYA PLASTIC MODEL CO.
628, Ushika, Shizuoka-City, Japan.



The Marder II

In the summer of 1941, German forces on the eastern front were elated with victory but, as they advanced east, ominous signs increased little by little. That is, they came to be confronted by the partisan guerilla tactics of Russian people and strong Russian tanks typified by the T-34. The ominous signs were illustrated by official reports and communications sent in rapid succession from field forces, which said that German weapons then in actual use had already become outdated.

The periodical report No.156 from the tactical staff of the 3rd Tank Division said about the toughness of T-34 tank's armour as follows:

"We had Second Lieutenant Steup shoot a T-34 tank with his 50 mm tank gun, one time at a distance of 20 metres and four times at a distance of 50 metres. As a result, we have found that even the armour piercing shell model 40 is not effective at all against the T-34. This is really worth noticing."

This report meant that even the 50 mm anti-tank gun model 38 — the best anti-tank gun then used by German tank troops and anti-tank gun troops — was no match for Russian main tanks.

The German Army ordered the Ordnance Bureau to develop new anti-tank guns in haste and at the same time studied how to fill up immediate needs. It was necessary to help infantry division's anti-tank gun battalions, then equipped mainly with 37 mm anti-tank guns, out of their miserable condition.

To meet the crying needs, the German Army paid attention to the Russian 76.2 mm multi-purpose field gun. The Germans already captured a large number of guns of this type and their ammunition in the initial stage of the war against the Soviet Union. The 76.2 mm field gun with 54 length calibre, muzzle brake, high muzzle velocity and low trajectory was powerful enough to harass the Germans. It was called "ratch bumm" by German soldiers.

The German Army Ordnance Bureau decided to mount the Russian 76.2 mm gun on the chassis (open top body) of the PzKpfw II Ausf D and E by way of a makeshift until the 75 mm anti-tank gun PaK 40, which was steadily nearing completion, was put to production. The 76.2 mm self-propelled anti-tank gun II types D and E (Sd.Kfz-132) was nicknamed "Marder II" ("Marten" is the English equivalent of the German "Marder".) and 150 were manufactured from December 1941 to June 1942.

Early in 1942, German weapons and tactics against Russian tanks saw a beam of hope on the horizon. The production of the 75 mm anti-tank gun got fairly under way and guns of this type came to be delivered in succession to anti-tank gun battalions. In addition, the main gun of the PzKpfw IV was reinforced.

Encouraged by the great popularity of the Marder II, the Ordnance Bureau ordered on 18th May 1942 to mass-produce the self-propelled anti-tank gun II equipped with the new 75 mm gun PaK 40/2 instead of the Russian 76.2 mm gun. In those days, the PzKpfw II already became outdated in fighting power and could not be used in missions other than reconnaissance and communication. Thus was born the 75 mm self-propelled anti-tank gun II types A, B, C and F (Sd.Kfz-131) — also called "Marder II" — based on the chassis of the PzKpfw II Ausf A, B, C and F. The body was remodelled by Alkett of Spandau and the 75 mm gun was modified by Rheinmetall AG.

The 75 mm anti-tank gun PaK 40/2 — its wheels, legs and suspension were removed but shield and sight remained as they were — was mounted on the centre of the PzKpfw II whose body top was completely removed. Large 10 mm armour plates were fixed to the body sides. The armour plates were designed to protect the crew from bullets and shell fragments but slightly reduced the angle of traverse from 65° to 57° i.e. left 32° and right 25°. To protect the gun barrel from

vibration in running, large barrel stays were fixed to the front of the body.

The Marder II carried a crew of three, commander, driver and loader. The commander had to grasp the situation of battle and also fire the gun. The driver had to serve also as signal man. The loader was also kept busy during fighting. He had to bring and load all by himself firstly 7 shells kept on the rack over the engine cover, secondly 24 shells on the left-hand rack and thirdly 6 shells on the right-hand rack.

Some changes based on battle experience were seen in vehicles manufactured from the end of 1942 onward. The handle for starting the engine was moved to the rear of the body and the wireless apparatus originally mounted beside the driver was shifted to the right of the loader in the fighting compartment. These changes were made because the driver served as the feeder of shells in fighting and also probably because the Marder II self-propelled anti-tank gun showed itself at its best in defensive action of attacking the enemy from ambush rather than in offensive action. Employed at about the same time were new headlights and anti-aircraft machine gun MG42, which were standard equipment of German tanks in those days.

The production of the Marder II self-propelled anti-tank gun was started in June 1942 but stopped in February 1943 by order of Adolf Hitler who intended to concentrate efforts on the manufacture of the "Wespe" self-propelled howitzer. In these months, 531 were manufactured.

The Marder II was one of the valuable vehicles that served as makeshifts for about two years from the beginning of the German-Soviet war to the appearance of typical tank destroyers on the eastern front. The Marder II self-propelled anti-tank gun delivered to poorly equipped anti-tank gun companies in infantry divisions rendered distinguished service as an important weapon to protect infantrymen from Russian heavy tanks.

PARTS

A PARTS

1. Cylinder Plug
2. Breech Part
3. Breech
4. Cylinder
5. Traverse Handwheel Shaft
6. Guide Rail
7. Balance Damper A
8. Balance Damper B
9. Gun Barrel (Right)
10. Gun Barrel (Left)
11. Shells
12. Empty Cartridges
13. Recoil Mechanism (Right)
14. Recoil Mechanism (Left)
15. Rack Cover
16. Sight A
17. Sight B
18. Elevation Handwheel Shaft
19. Recoil Mechanism Cover
20. Breech Operating Lever
21. Saddle (Right)
22. Loading Section (Upper)
23. Protection Plate (Rear)
24. Saddle (Left)
25. Protection Plate (Front) A
26. Protection Plate (Front) B
27. Loading Section (Rear)
28. Recoil Mechanism (Front)
29. Cam
30. Movable Gun Shield
31. Sight Case
32. Case A
33. Case B
34. Protection Plate Stays
35. Case C
36. Elevation Handwheel
37. Traverse Handwheel

B PARTS

1. Radio Rack A
2. Radio Rack B
3. Gun Base
4. Gun Travel Lock A
5. Gun Travel Lock B
6. Support
7. Case D
8. Case E
9. Shovel
10. MG 34
11. Schmeisser
12. MG 34 Magazine
13. Light
14. Periscope
15. Case F
16. Radio Rack C
17. Gun Travel Lock C
18. Protection Plate (Right)
19. Rear Hinge
20. Shell Case A
21. Shell Case B
22. Shell Case C
23. Inside Panel A
24. Wire Rope
25. Protection Plate (Left)
26. Hull Upper Peep Hole
27. Support Shield (Left) A
28. Support Shield (Right) A
29. Shell Case A Lid
30. Antenna Stay
31. Support Shield (Left) B
32. Support Shield (Right) B
33. Front Hook
34. Inside Panel
35. Front Armour Plate
36. Inside Panel C
37. Protection Plate (Right) Stay
38. Gun Travel Lock D
39. Shell Case Inside Plate
40. Saw
41. Pick Ax
42. Upper Hull

C PARTS

1. Spare Track Links
2. Figure A (Left Arm)
3. Figure A (Upper Half)
4. Figure A (Right Arm)
5. Figure A (Lower Half)
6. Rear Bulkhead
7. Rear Panel
8. Figure B (Body)
9. Figure B (Left Arm)
10. Figure B (Right Arm)
11. Wood Case (B 1)
12. Wood Case (B 2)
13. Wood Case (B 3)
14. Wood Case (B 4)
15. Helmet
16. Tail Pipe
17. Driver's Seat
18. Transmission Housing
19. Transmission
20. Floor Panel
21. Road Wheels
22. Drive Shaft A
23. Drive Shaft B
24. Support Plate
25. Air Cleaner B
26. Air Cleaner C
27. Rear Wheels
28. Sprocket Wheels
29. Silencer
30. Wood Case (A 1)
31. Wood Case (A 2)
32. Spare Wheel
33. Wood Case (A 3)
34. Air Cleaner Mount
35. Rear Hook
36. Idler Wheels
37. Wheel Cap Stopper
38. Rear Wheel Cover
39. Sprocket Wheel Covers

A PARTS

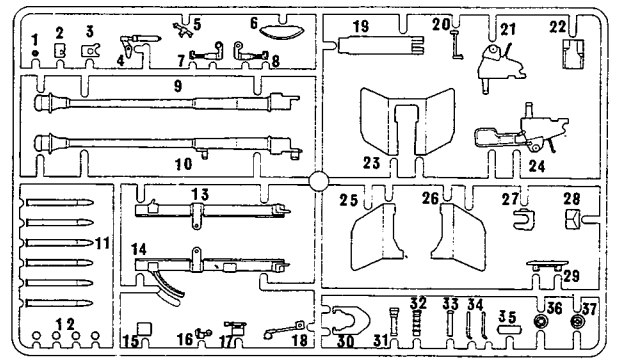

B PARTS

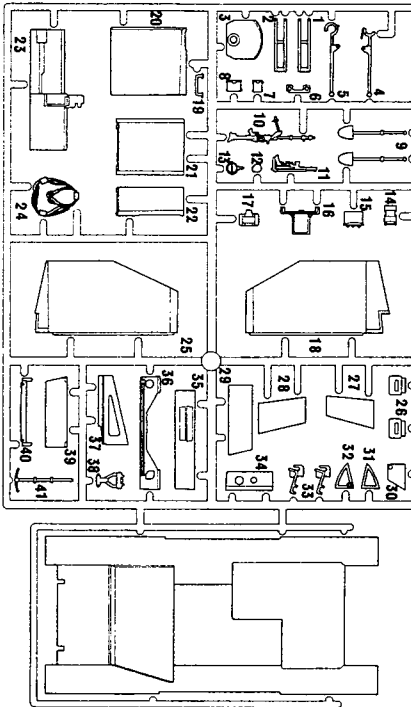

C PARTS

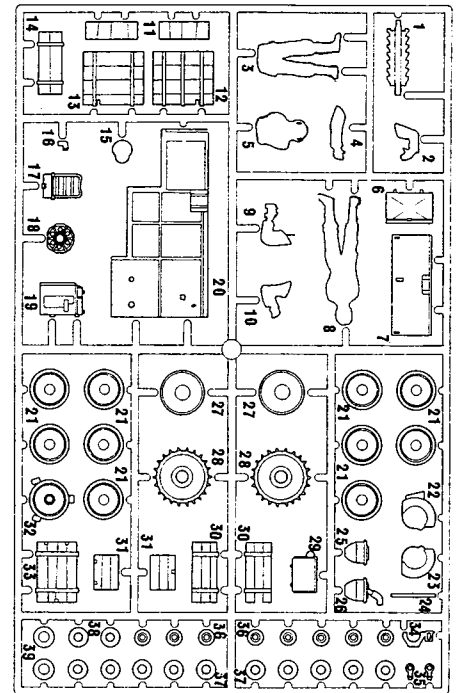



- ★Study the instructions and photographs before commencing assembly.
- ★You will need a sharp knife, a pair of tweezers, a file, and a pair of pliers.
- ★Do not break parts away from sprue, but cut off carefully with a knife or a pair of pliers.
- ★Use glue sparingly. Use only enough to make a good bond.
- ★Paint the overall hull after completion.

1 (Construction of Gun Barrel)

Breech Block A2 and A3 can be slid. This was moved to right and left to load a shell and to get an empty cartridge out. Besides the horizontal type breech of 75mm Gun, there were the vertical slide type and screw type breeches.

3 (Construction of Saddles)

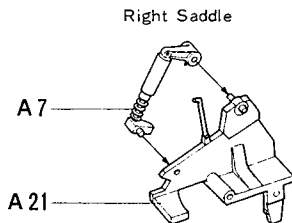

Right Saddle

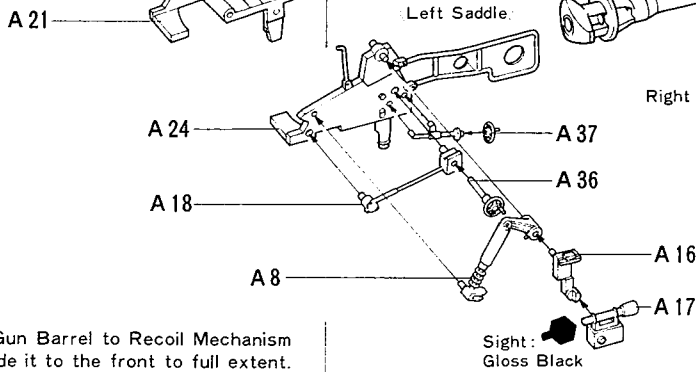

Left Saddle

★Fit Gun Barrel to Recoil Mechanism and slide it to the front to full extent. This state is a normal position of Gun Barrel.

4 (Construction of Gun Shield)

Shield A30 can be moved up and down, interlocking with the Gun Barrel. Do not cement and assemble to make this part movable.

1 Construction of Gun Barrel

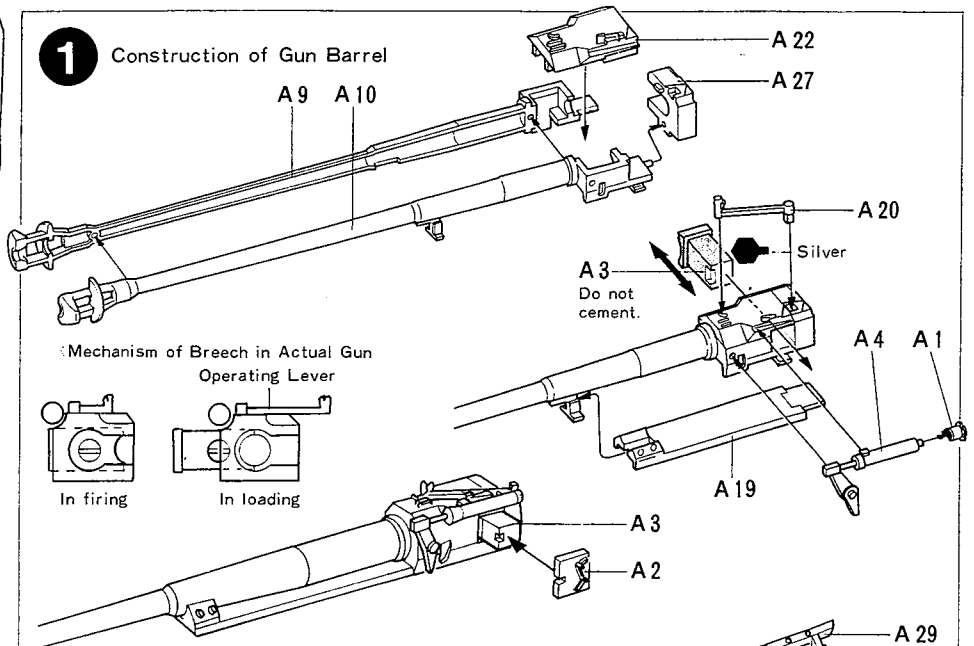

2 Construction of Recoil Mechanism

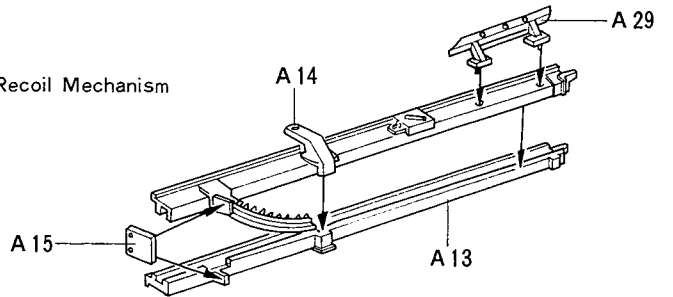

3 Construction of Saddles

★The gun barrel is at the normal position when slided inside Recoil Mechanism forward to full extent.

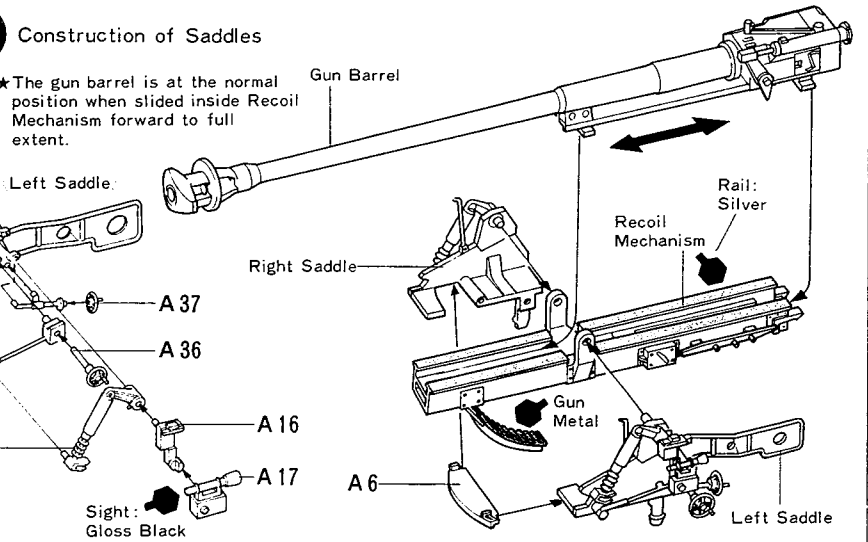

4 Construction of Gun Shield

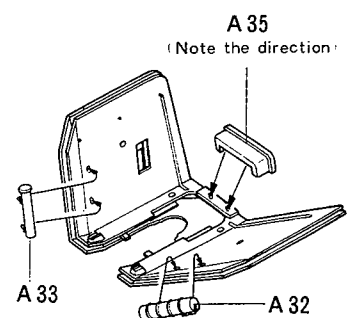
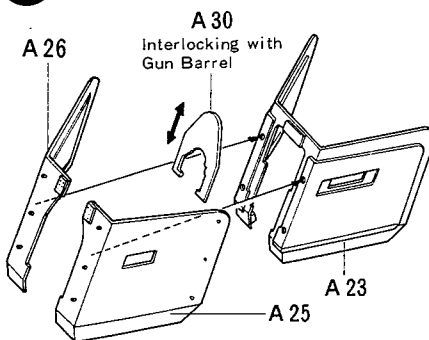

8 Construction and Fixing of Wheels

Construct 2 Sprocket Wheels, 10 Road Wheels and 2 Idler Wheels. Poly Cap which is put between each wheel is designed to rotate. Do not cement.

Construction of Tracks

★① Firstly, fasten one end of track onto a desk with tape and insert pins into respective holes. Then, lightly warm the pinheads with either a nail head or the end of a screwdriver that has been previously heated by a candle fire or the like.

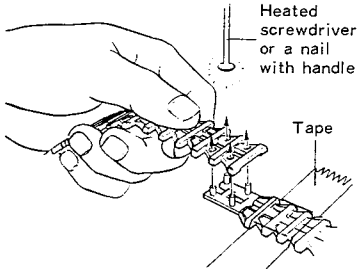

★② Flatten the pinheads immediately with your finger to connect track.

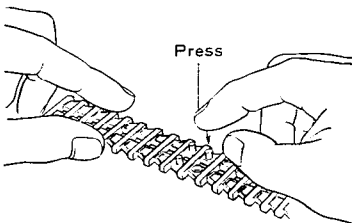

★In case track break or is unfastened due to ineffective flattening, re-fix it with sewing using a black thread or with a stapler as shown in the figure.

★To join the tracks, a heating device such as a candle is needed. Take care in handling such device. Avoid injury or fire.

9 Construction of Inside Panel

Make sure of the parts to be cemented and then fix.

10 Construction of Splash Protection Plates

Construct left and right Splash Protection Plates. B18 should be fixed to the right side, and B25 to the left.



8 Construction and Fixing of Wheels

Sprocket Wheel

Make 2 sets.

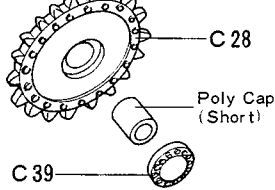

Road Wheel

Make 10 sets.

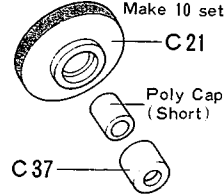

Idler Wheel

Make 2 sets.

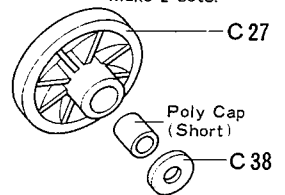

★Do not apply cement to Poly Caps.

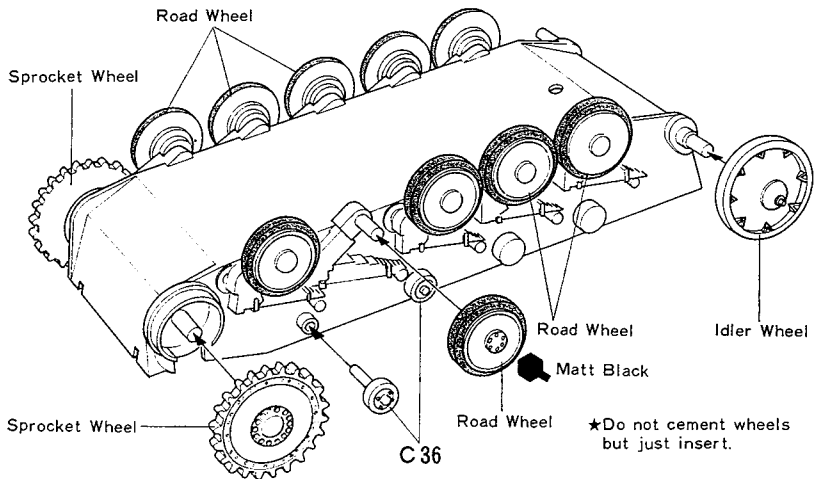

★Do not cement wheels but just insert.

9 Construction of Inside Panel

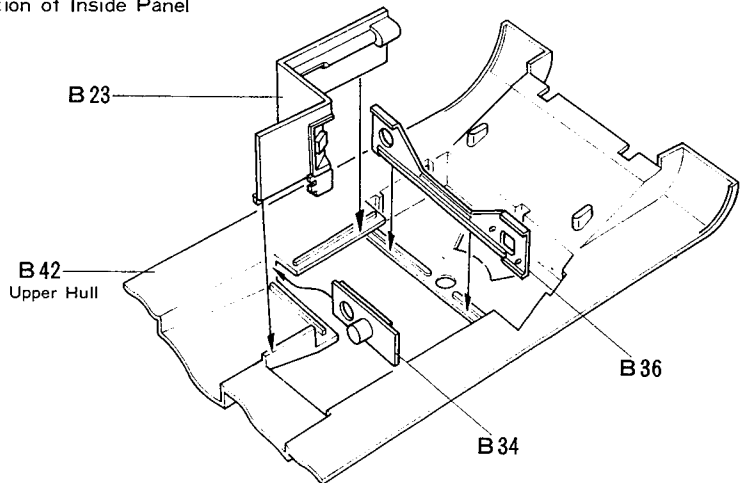

10 Construction of Splash Protection Plate

Right Protection Plate

Inside: Same as body colour

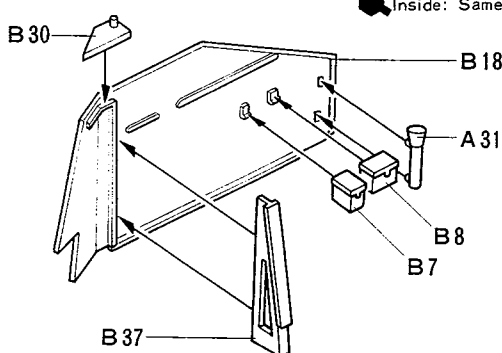

Left Protection Plate

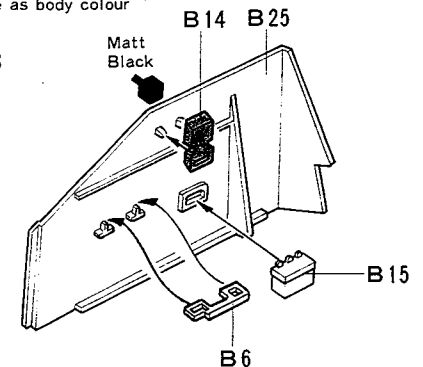

11 Fixing of Hull Parts

Cement Splash Protection Plates and Air Cleaner etc. to Upper Hull. Gun Travel Lock B38 is movable. Hold this in position with B17.

(Construction of Air Cleaner)

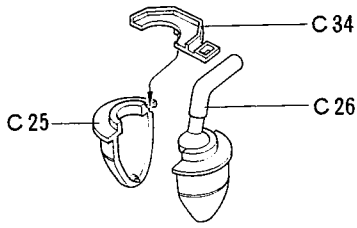

12 Fixing of Ammunition Box

Ammunition Box A can be constructed in two ways, in action or in running. Choose either one you prefer. Cement B19 and B41 to Ammunition Box A (B20).

Construction of Ammunition Box A
In running

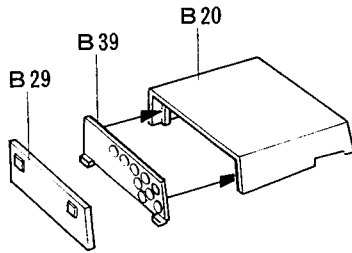

In action

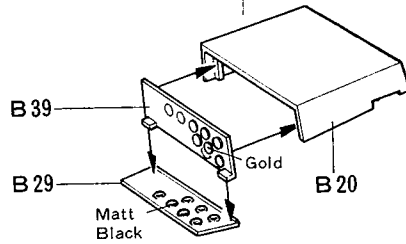

13 Fixing of Upper Hull Parts

Choose either Wire Rope B24 or Spare Wheel C32 and fix.

How to Make Antenna

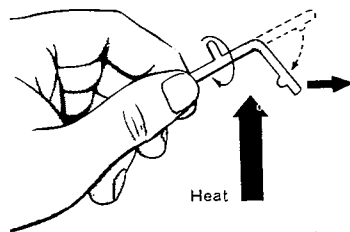

When the runner hangs down, as shown in the figure, take it away from the heating device. Then, slowly stretch it both ways until it becomes long and slender. Keep it still for about 15 seconds to cool. Lastly, cut it to a piece of 4 cm.

Be careful in Handling fire.

11 Fixing of Hull Parts

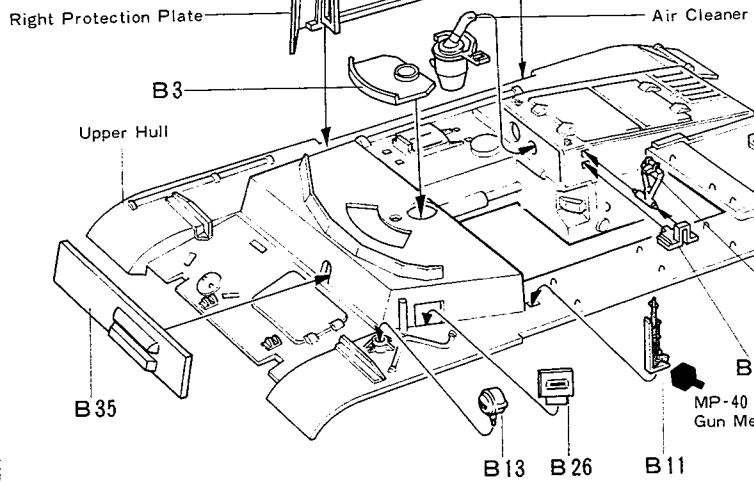

12 Fixing of Ammunition Box

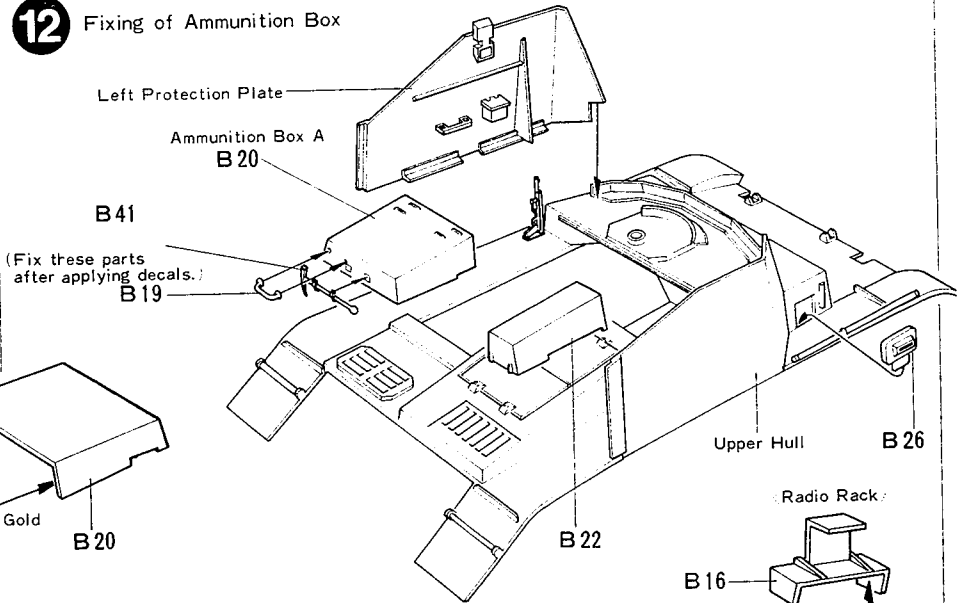

13 Fixing of Upper Hull Parts

Choose either B24 or C32 and cement.

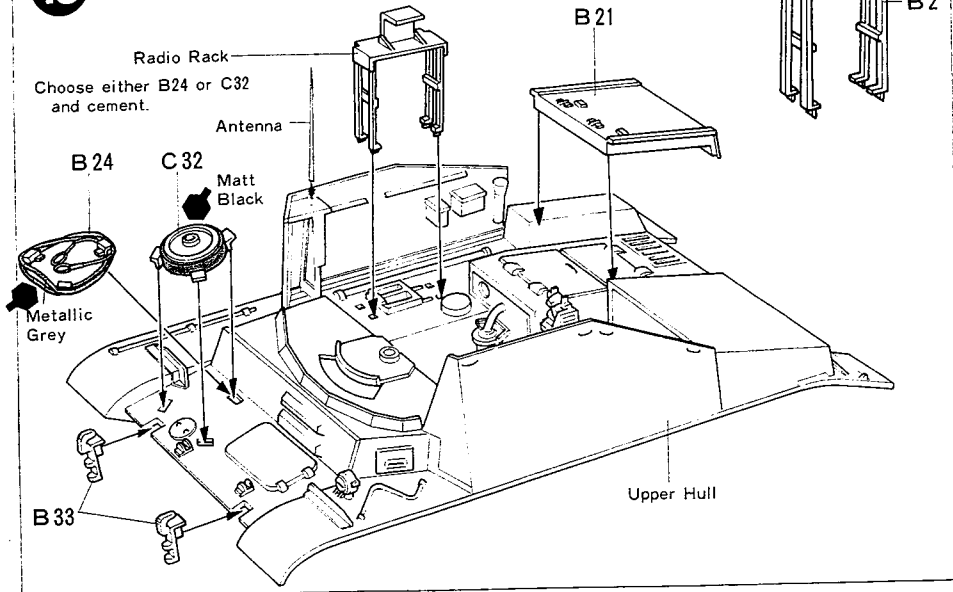

14 Mounting of Gun

B5 and B4 can be constructed in either in action or in running. When you construct the running state, refer to 16 and the photo below.

Construction of Wood Case:

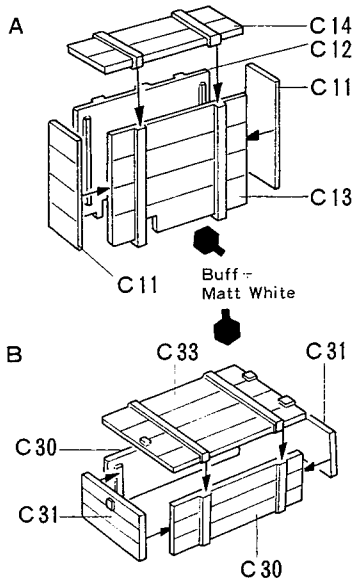

★Helmet, Shells, and Empty Cartridges are optional.

★Painting colour

Helmet — Field Grey
Shells — Top: Matt Black
Cartridge: Gold

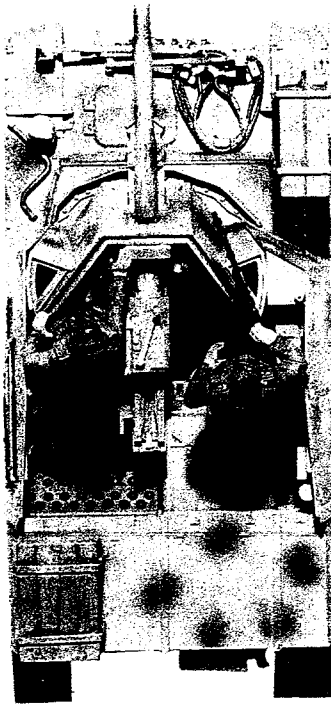

16 Construction and Painting of Figures

Mount Figures as shown in the photo above.

14 Mounting of Gun

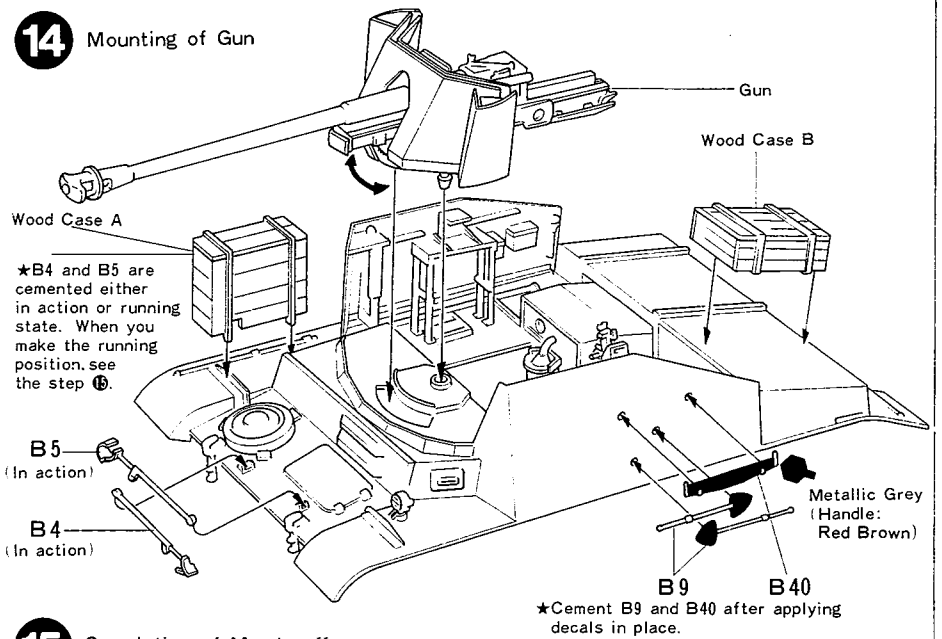

15 Completion of Marder II

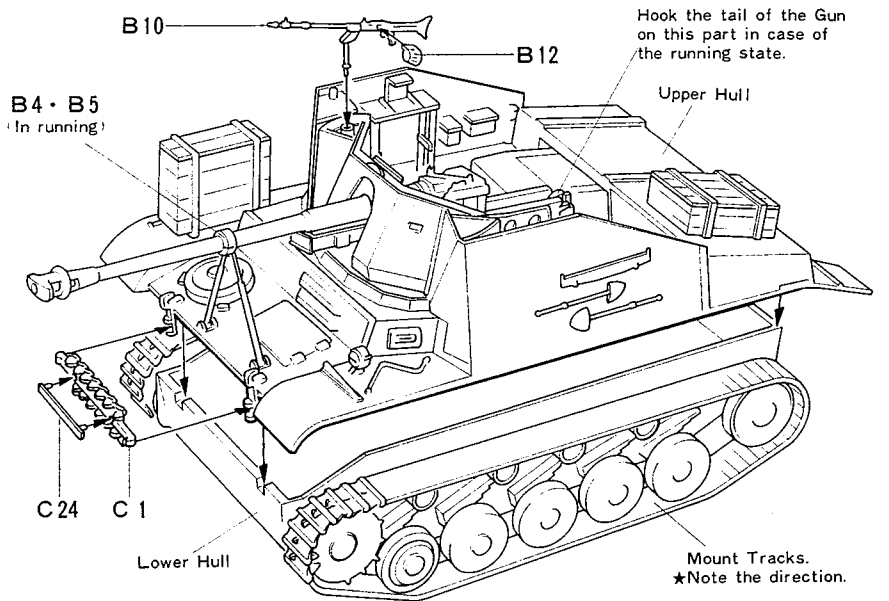

16 Construction and Painting of Figures

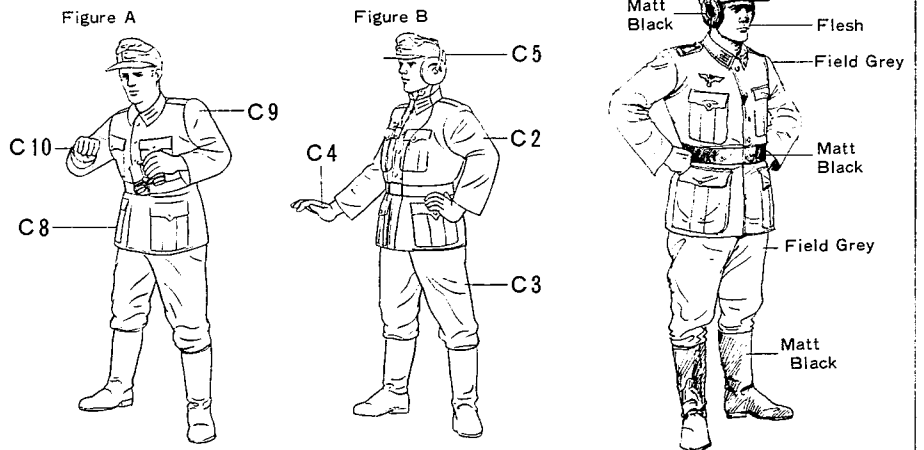

PAINTING & APPLYING DECALS

Painting of Marder II

From 1935 to February 1943, German military vehicles for use in Africa wore uniform painting of dark yellow, camouflage of reddish brown on a dark yellow ground or camouflage of dark green on a German Grey ground, while those for use in Europe were painted German Grey overall. In 1942, the two kinds of camouflage for Africa were replaced with camouflage of reddish brown on a dark yellow ground. In Russia, German vehicles were painted in water paint of flat white in winter.

On 18th February 1943, the military authorities decided to accept only dark yellow as the basic colour. Field forces applied other colours on the basic colour according to the terrains and gave various camouflage patterns. Applied for camouflage on the dark yellow ground were reddish brown, and dark green.

Painting of Marder II

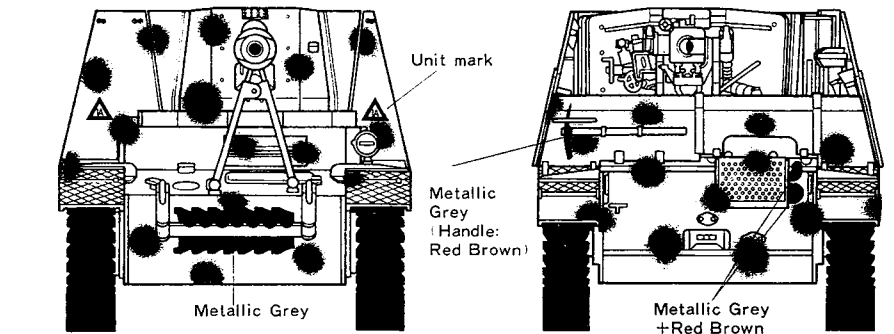
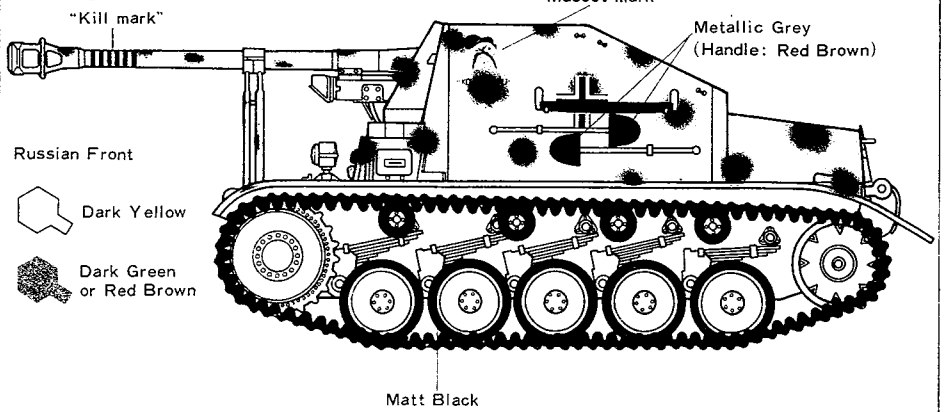



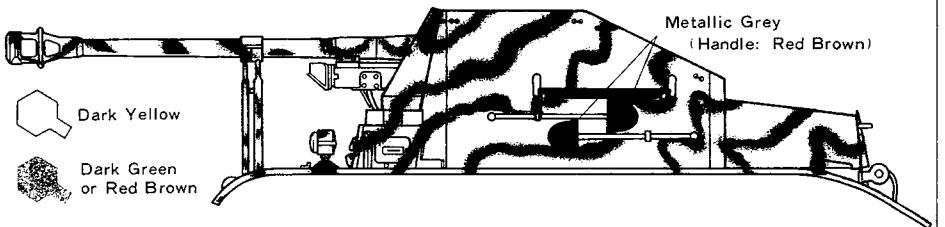

Example of Camouflage Painting



Marking of Marder II

The Marder II's have showed activity mainly on the Russian Front and were used as infantry support tanks. So they belonged to Infantry Division, Mechanized Infantry Division, or Panzer Grenadier Division.



Divisional Mark

	320th Infantry Division		216th Infantry Division
	168th Infantry Division		16th Mechanized Infantry Division
	10th Panzer Grenadier Division		

Tactical Mark

	Self-propelled Anti Tank Gun
---	------------------------------

Other Marks

	Unit mark
	Mascot mark

Position of Marks

