

I-16 & I-58

JAPANESE NAVY SUBMARINE

ウォーターラインシリーズ

伊-16・伊-58

日本潜水艦



ITEM 31434

TAMIYA

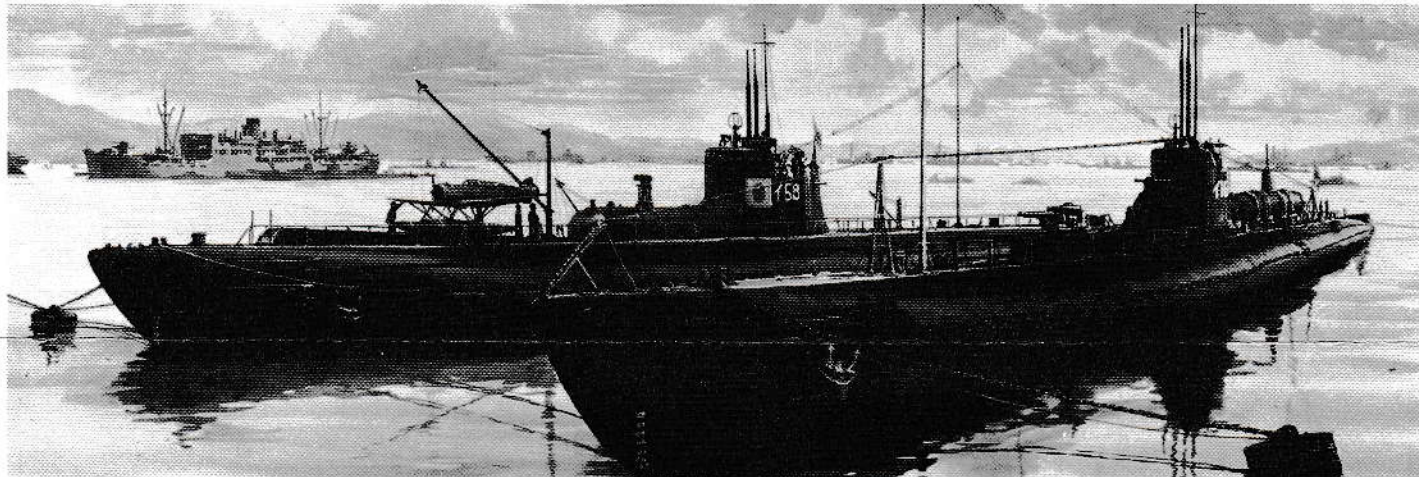

Illustration by Kihachiro Ueda

WATER LINE SERIES

At the beginning of the Pacific War the Japanese Navy had 63 submarines. This was a similar number to those possessed by the German Navy at the outbreak of World War II, although their size and the roles they played were quite different. German submarines were, on the whole, quite small vessels of the 350 ton and 700 ton classes. The Japanese submarines were all large-sized in comparison, including eleven of the 1,000 ton class, four of the 1,400 ton class, twenty-one of the 1,700-1,800 ton class and another twenty-one measuring more than 2,000 tons. A difference in submarine roles of the two navies attributed to the varying sizes. The Germans used their submarines mainly to attack commercial and transport shipping. The Japanese submarines on the other hand were used to assist their fleets in battle by attacking the enemy. Their range was sufficient enough for them to patrol the seas near mainland America. Their large dimensions, powerful armament and ability to travel great distances with superior sea-going qualities made it possible for the submarine even to engage the enemy in high seas. The main strength of the submarine force comprised thirteen vessels of the Type I-9 (Kou Type), Type I-15 (Otsu Type) and Type I-16 (Hei Type) constructed under the Third Naval Replacement Program in 1937. The types varied in the equipment and the number of torpedo tubes that they possessed. The submarines were manufactured with the latest techniques and were superior in performance to any produced by any other naval power.

The I-16 Submarine (Hei Type)

Whereas the Kou Type were designed primarily to be the flagships of the submarine squadrons and the Otsu Type for reconnoitring duties, the Hei Type were planned solely for attack purposes. The Hei Type submarine mounted all of their eight torpedo tubes on the bow. This configuration meant the Hei Type was the most potent submarine in the world. The first I-16 submarine of the Hei Type was completed on March 30th, 1940. The I-16 participated in the attack on Pearl Har-

★Special purpose submarine Kohyoteki

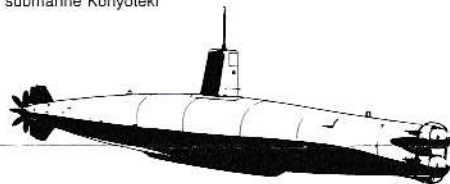

bor with a special purpose submarine called the Kohyoteki on board.

During subsequent action in the Indian Ocean Operations, the I-16 attacked Diego-Suarez Bay of Madagascar Island with her Kohyoteki and destroyed the British battleship Ramillies, the submarine British and sank a tanker. On November 28th, 1942, the I-16 severely damaged the American transport Alkiba with her Kohyoteki off Lunga Bay. The I-16 left Truk Island on May 14th, 1944 to transport materials to Buin, but became missing in action. It was later verified that the I-16 was sunk by the destroyer England.

★The Kohyoteki was a small submarine that was designed to be launched from a submarine mother ship to get very near a target to torpedo it. The Kohyoteki was about 24 m in length and carried two torpedoes and two crew. Five Kohyotekis were used in the attack on Pearl Harbor.

The I-58 Submarine (Otsu Type)

The I-58 submarine was an Otsu Type vessel. Additional Otsu Type vessels comprising six Type I-40's and three Type I-54's were to be built under the 1941 program. The I-58 was completed as the third vessel of the Type I-54. Distinctive features of the I-58 was that it carried a Type O small reconnaissance seaplane E-14 (Glen) and a catapult to launch it, for reconnoitring was the I-58's primary function. The I-58 mounted six torpedo tubes, three on each side of the bow. In January 1945, the I-58 first saw action as the mother ship of human torpedoes called Kaiten. Joining the Kongo Unit of the Kaiten Special Attack Corps, the I-58 attacked Apra Harbor of Guam with her four Kaitens. Subsequently the I-58 sailed to Okinawan Waters and in July joined the Tamon Unit and made a sortie towards the East Caroline Islands. On July 30th, 1945, the I-58 torpedoed and sank the American heavy cruiser Indianapolis, north of Palau Island. The I-58 then returned to her home port of Kure on August 14th, 1945, one day before the war finally ended.

★American heavy cruiser Indianapolis



★The Indianapolis was an American heavy cruiser of the 10,000 ton class. When sunk by the I-58, some people claim the Indianapolis carried on board the third atomic bomb, to follow those dropped upon Hiroshima and Nagasaki.

I16&I58

 Name Plate

Read Before You Start Your Assembly Work:
★When cutting Parts off the runner, be sure to do so carefully with the aid of a pair of nippers, a knife or the like.
★When gluing two parts together, always try to apply adhesives sparingly onto both surfaces.

WATER LINE SERIES

I16

1 Construction of Bridge

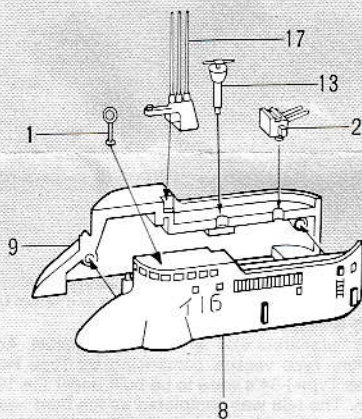

2 Construction of Hull

For a submerged submarine do not fit mast, derrick etc. For a surfaced submarine drill holes through the reversed side of the deck and attach mast, derrick with adhesive.

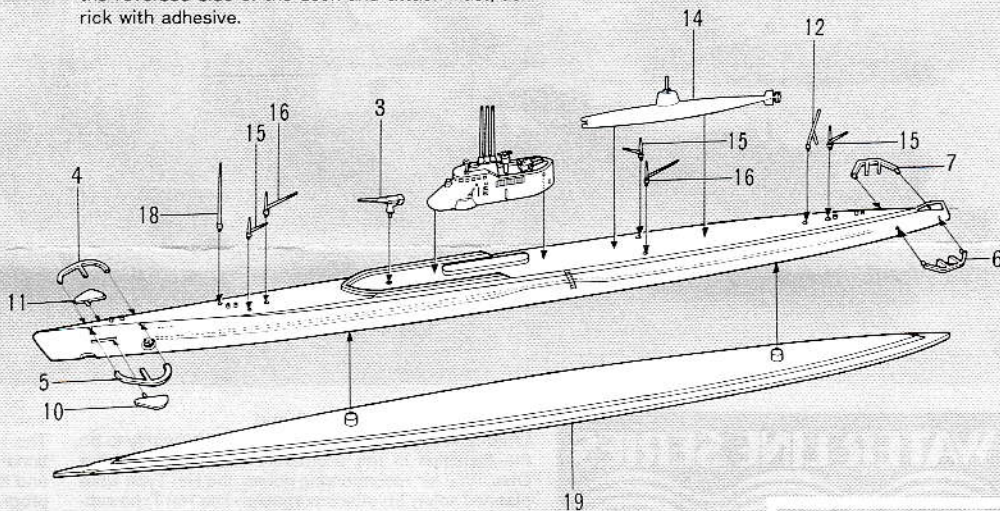

I58

1 Construction of Bridge

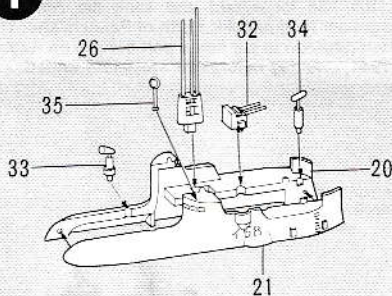

3 Construction of Hull

For a submerged submarine do not fit mast, derrick etc. For a surfaced submarine drill holes through the reversed side of the deck and attach mast, derrick with adhesive.

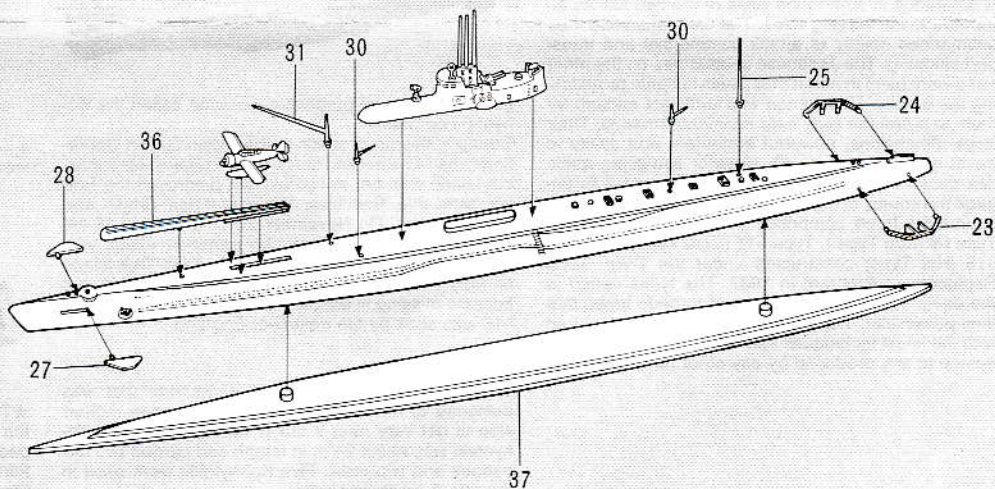

2 Construction of Seaplane

