

Lorinser

MERCEDES-BENZ 500SEC



1/24 SPORTS CAR SERIES



If you have lots of money, want something unique, and are looking for a real status symbol, then going to the Lorinser Benz dealer in Europe is a good place to go! Lorinser, a well known dealer in Germany also specializes in dressing up the Benz products for their buyers. Like b+b for Porsche, Alpina for BMW, Oettinger for VW and others, the Lorinser firm in West Germany caters to their clients. From a personal car to a truck, in fact the entire Benz line can be done up to your tastes. The 500 SEC Mercedes-Benz done up by Lorinser, made its debut in 1981, and it is considered the top of the line in dressed up luxury cars. It is a four seat, 2 door coupe based on the 4 door saloon Benz and is considered to be the highest class, highest performing luxury car in the world. Overall length is 4910mm with a wheel base of 2845mm. These are each 85mm shorter than 500SE saloon, but the mechanics are the same. The 5 litre water cooled V8 engine of SOHC format, puts out 231 horsepower, and propels this 1.6 ton automobile to a smooth 225 km/h. Four wheel independent suspension, with front double wishbone and coil dampening, plus a front end anti nosedive system to keep the car level during hard braking. The rear has an anti-squat system for level running during rapid acceleration. The ventilated front disc brakes and rear discs have been matched to the increased performance of this upgraded car. The new body is 3cm lower than the saloon car. The

frontgrill styling, used since the 300SL, is the trademark of Benz and is retained in the Lorinser as well as the well known three pointed star. This model differs from the standard saloon car in so many ways that it is easily recognizable. The front air dam, rear spoiler, side skirts and stern spoiler set it apart from the others. Even the almost indestructible bumper is unique and these features provide the safety and stability during fast trips on the German Autobahns. The interior is finished even more luxurious and sporty than the already comfortable 500SEC. In addition to the sports type steering wheel, Recaro seats, which are made only for the finest sports car, have 8 different seat adjustments, including individual heaters. A high fidelity stereo system, TV and Bosch car telephone are included. Staying ahead of your neighbors is no problem if you own a Lorinser Benz.

* * *
Wenn man viel Geld hat und etwas Einmaliges haben will, so ein richtiges Status Symbol, sollte man zum Sport Service Lorinser gehen. Die Firma Lorinser in Waiblingen in der Nähe Stuttgarts, hat sich darauf spezialisiert, Mercedes Wagen sportlich aufzuputzen. Wie b+b für Porsche, Alpina für BMW, Oettinger für VW, so bemüht sich Lorinser alle Wünsche seiner Kunden zu erfüllen. Der Mercedes 500 SEC von Lorinser wurde 1981 vorgestellt und dürfte die Spitze

der Luxus-Wagen sein. Das Coupe hat 4 Sitze und zwei Türen auf dem Fahrgestell des 4-türigen Mercedes 500. Gesamtlänge ist 4910mm mit einem Radstand von 2845mm, also 85mm kürzer als der 500SE, die Mechanik aber blieb die Gleiche. Der 5 Liter, wassergekühlte V8 Motor mit SOHC bringt 231 PS und das Fahrzeug mit 1,6 ton auf 225 km/h. Der Wagen hat Einzerradaufhängung, vorne doppelte Federbeine mit Schraubenfedern, sowie Anti-Nosedive System, damit der Wagen bei hartem Bremsen vorne nicht wegtauchen kann und hinten das Anti-Squat System, das den Wagen bei grossem beschleunigen ebenfalls immer in der gleichen Lage hält. Die Bremsscheiben sind ebenfalls ventiliert. Die Karosserie ist 3cm niedriger, der Frontgrill trägt den Mercedes-Stern. Dieser Lorinser 500 SEC unterscheidet sich in so vielen vom normalen Mercedes 500, man sieht sofort den Lorinser, der vordere Lufteinlass, der hintere Spoiler, die Seitenschürzen, alles ist nicht zu übersehen. Der fast nicht umzubringende Stossfänger ist speziell für diesen Wagen gebaut und verspricht grösste Sicherheit bei schnellem Fahren auf den Autobahnen. Das Interieur ist noch luxuriöser und sportlicher als beim komfortablen 500 SEC. Zum sportlichen Lenker kommen noch Recaro Sitze mit 8 verschiedenen Sitzverstellern. Eine HiFi-Stereo Anlage und Bosch-Auto-telefon sind ebenfalls vorhanden.

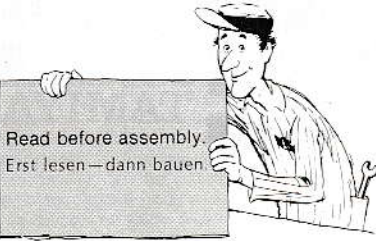

Read before assembly.
Erst lesen—dann bauen.

- ★ Study the instructions and photographs before commencing assembly.
- ★ Use glue sparingly. Use only enough to make a good bond. Apply cement to both parts to be joined.
- ★ Before cementing plated parts, remove plating with a knife etc. from the surface to which cement is applied.
- ★ Do not break parts away from sprue, but cut off carefully with a pair of pliers.

● This mark denotes paint color, and the color names and numbers are for Tamiya Acrylic Paints and Tamiya Paint Markers. Page 8 has detailed painting instruction, however, some parts should be painted prior to model's completion, and these are called out during assembly.

★ Vor Beginn die Bauanleitung studieren und den Nummern nach die Bauteile zusammenbauen bzw. zusammenkleben.

★ Teile vor dem Kleben zusammenhalten und auf richtigen Sitz achten. Kleine Teile hält man mit Pinzette fest.

★ Chrometeile: Vor dem Kleben muss und den Klebestellen die Chromschicht angeschabt werden, da sonst Klebstoff nicht bindet.

★ Bauteile nicht vom Spritzling abbrechen, vorsichtig abschneiden oder abzwicken.

● Dieses Zeichen zeigt die Farbe und Farbnnummer der Tamiya Acryl-Farben und Paint Marker.

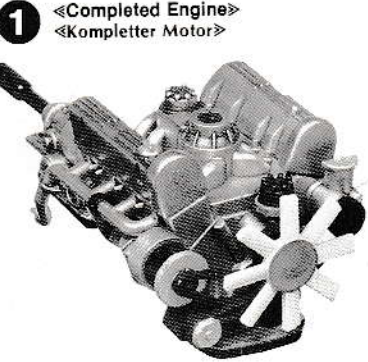

1 <<Completed Engine>>
<<Kompletter Motor>>

- ★ Do not break parts from sprue, but cut off carefully with a pair of pliers.
- ★ Bauteile nicht vom Spritzling abbrechen, vorsichtig abschneiden oder abzwicken.

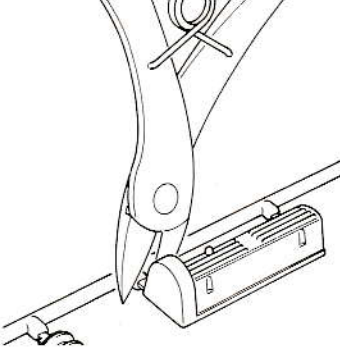

1 Assembly of Engine
Zusammenbau des Motors

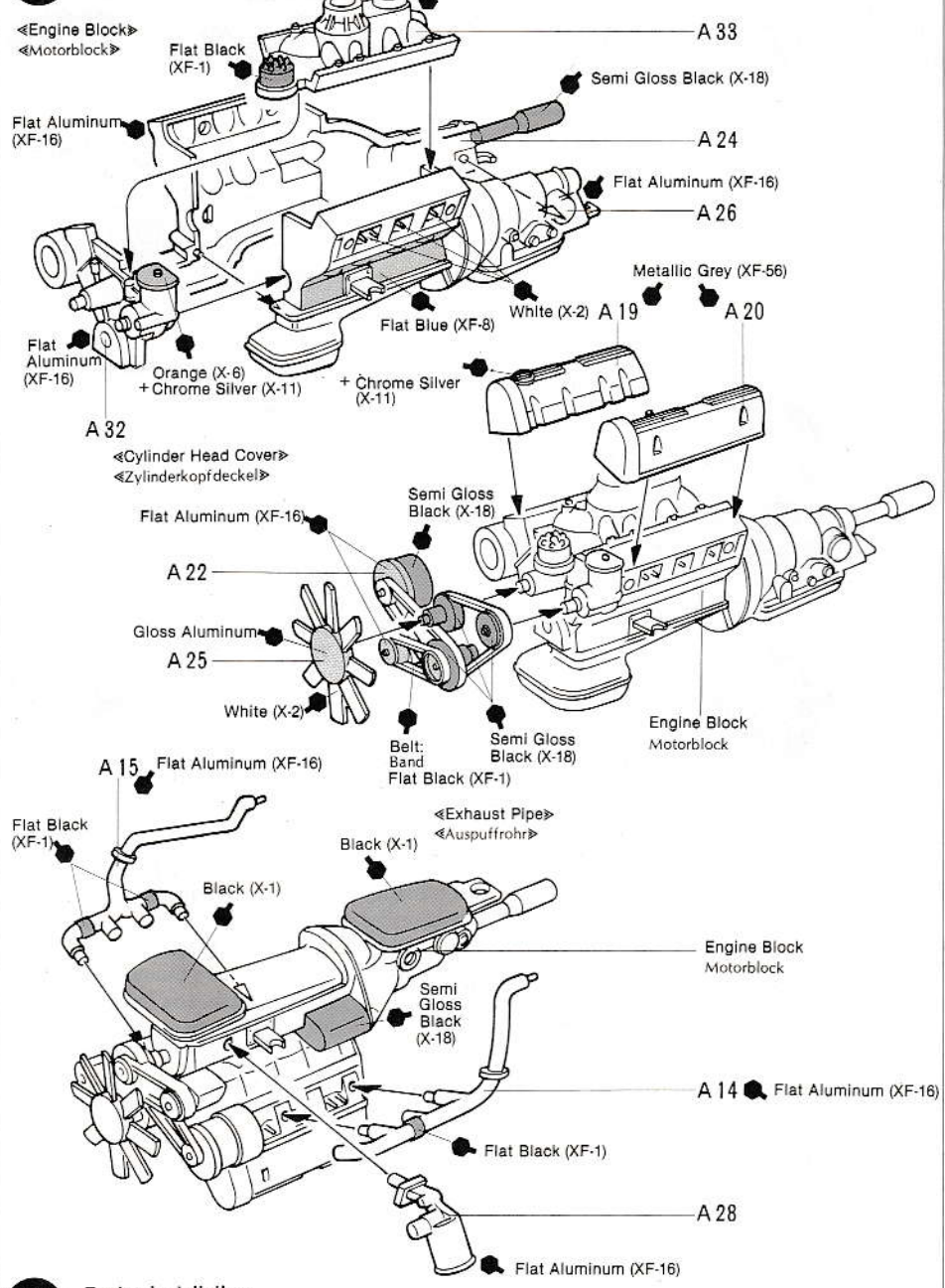

2 Engine Installation
Einbau des Motors

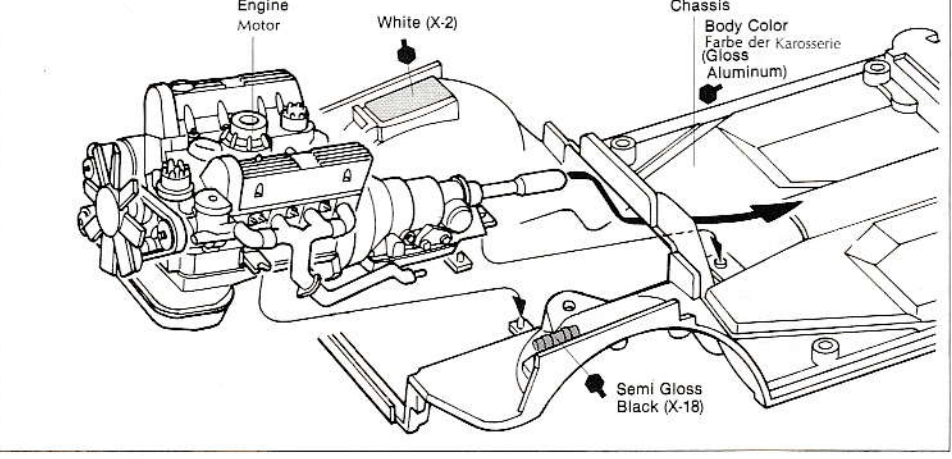

3 <<Attached Radiator>>
<<Eingebauter Kühler>>

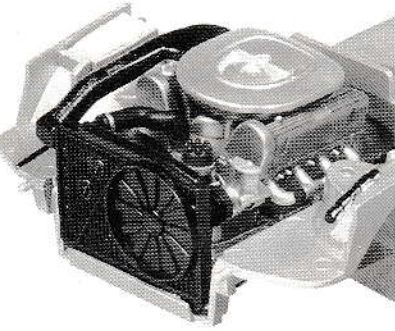

3 Attaching Radiator
Einbau des Kühlers

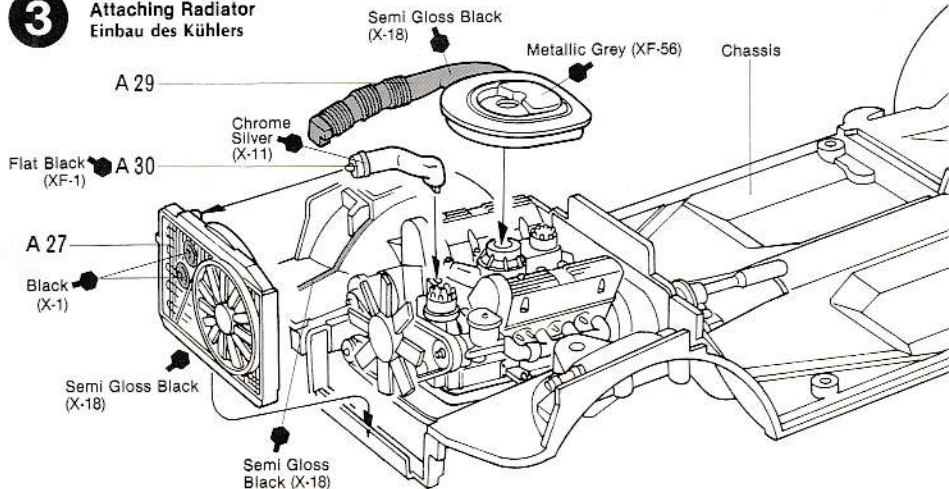

4 <<Assembly of Front Disc Brake>>
<<Vorderscheibenbremse>>

(Left)
(Links)

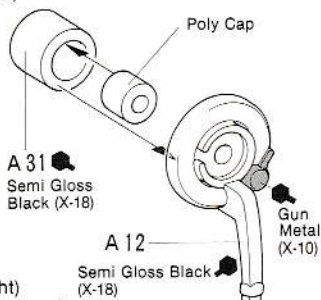

(Right)
(Rechts)

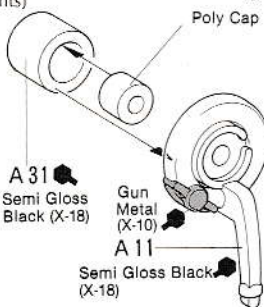

4 Front Suspension
Vordere Achsaufhängung

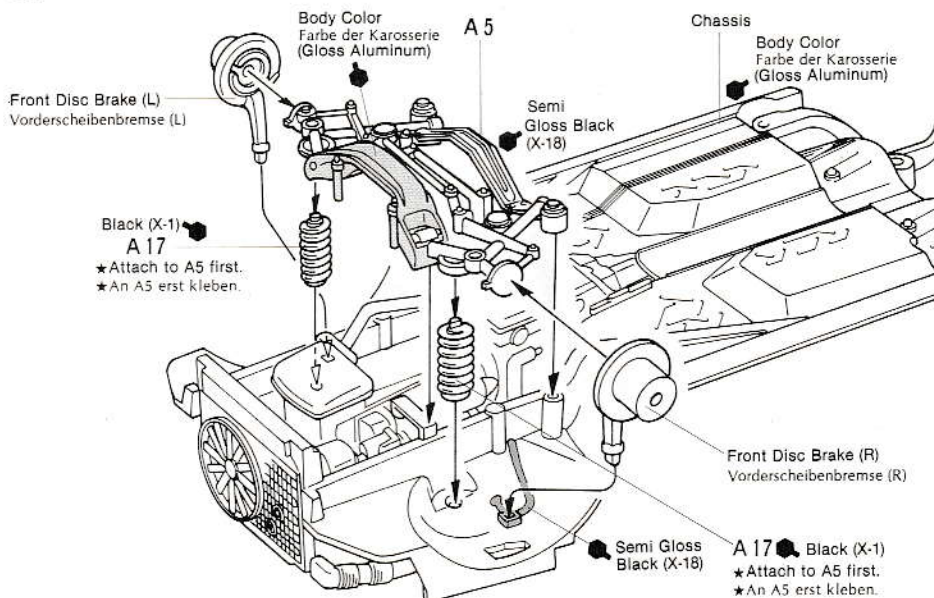

5 Attaching Rear Subframe
Hinterer Nebenrahmen

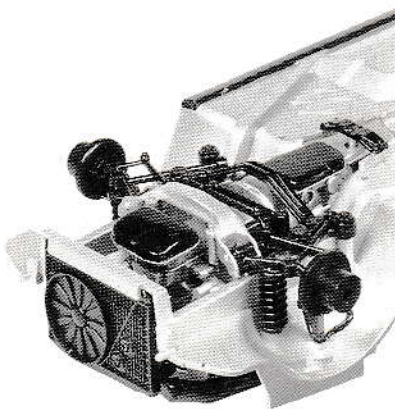
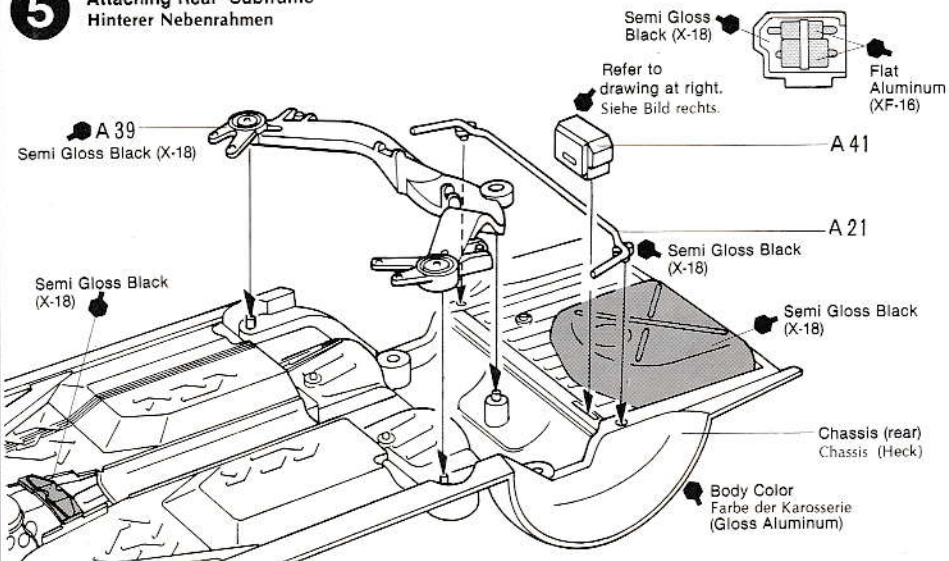

TAMIYA HEXAGONAL BOTTLE

Tamiya cement in a new hexagonal bottle for increased stability. Difficult to upset and easy to apply with the built in brush dispenser. The preferred plastic cement for beginners and experts alike.



8 «Attached Wheels» «Eingebaute Räder»

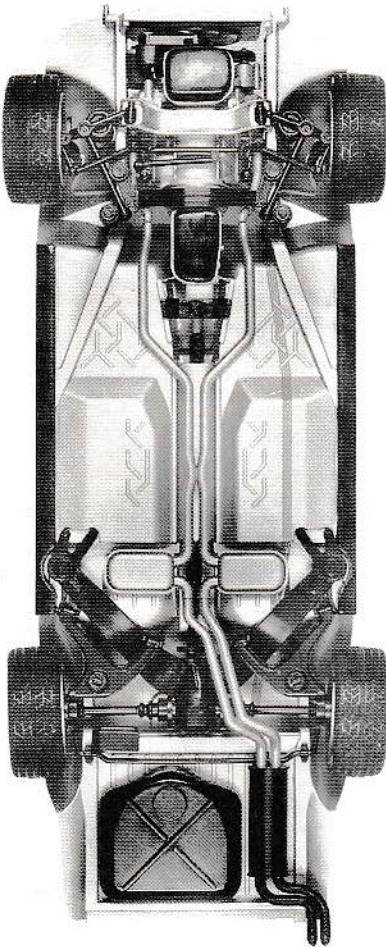

6 Assembly of Wheels Zusammenbau der Räder

«Wheel» ★ Make 4 sets.
«Räder» ★ 4 Satz machen.

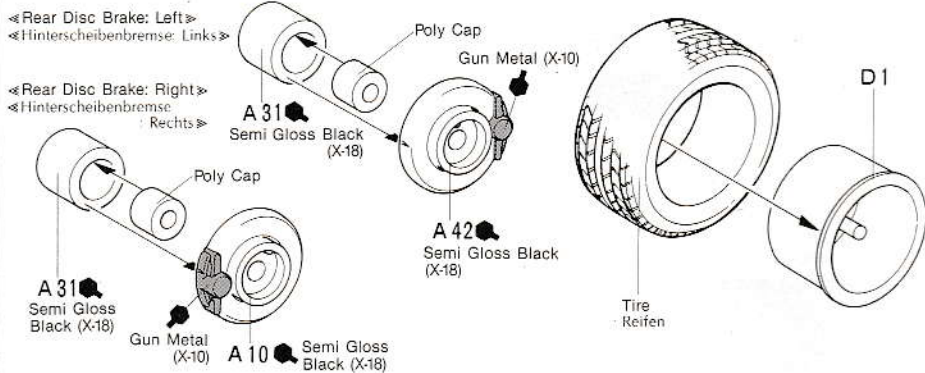

7 Rear Suspension Hintere Achsaufhängung

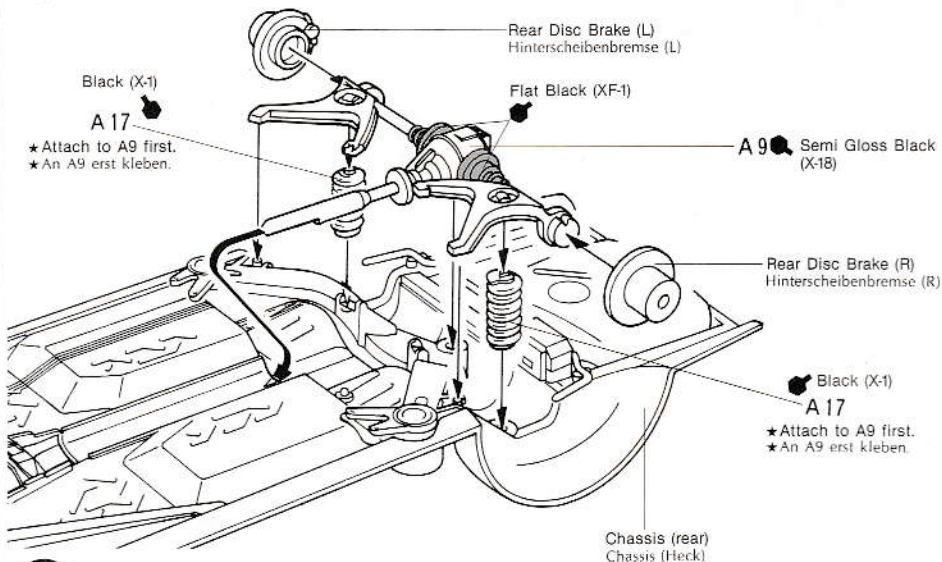

8 Attaching Wheels Einbau der Räder

★ Snap wheels into place as shown.
★ Nicht kleben, nur eindrücken.

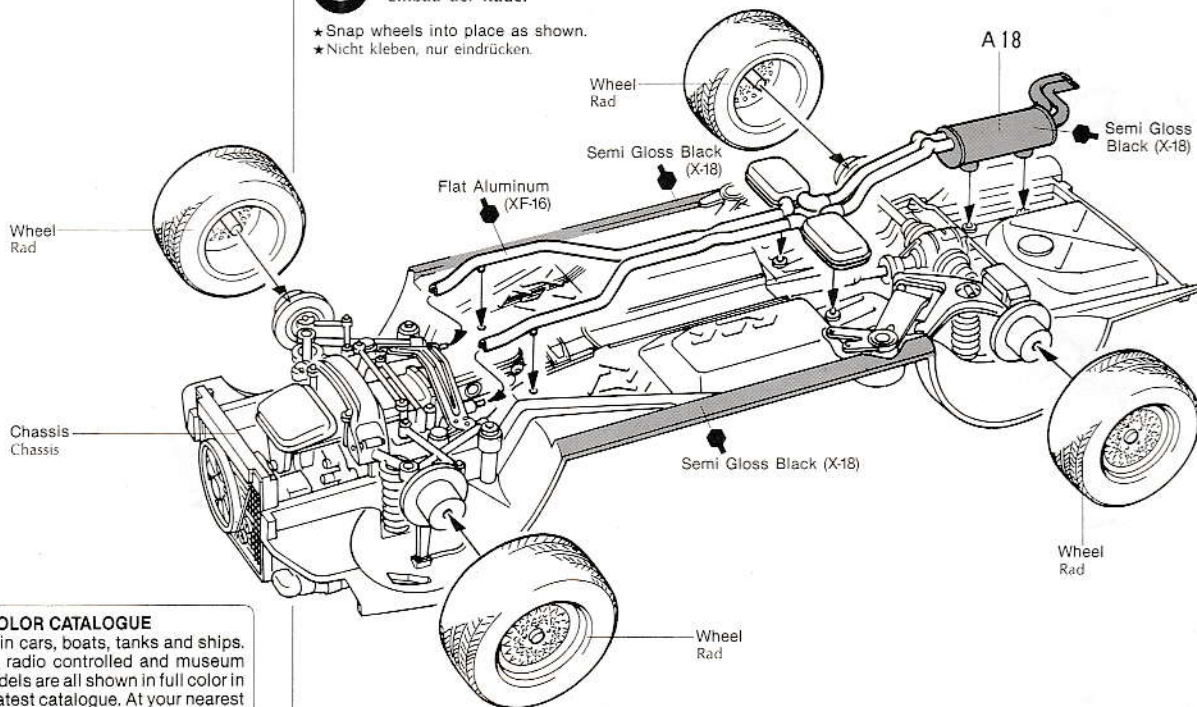

TAMIYA COLOR CATALOGUE
The latest in cars, boats, tanks and ships. Motorized, radio controlled and museum quality models are all shown in full color in Tamiya's latest catalogue. At your nearest hobby supply house.

<<Body & Interior Colors>>

<<Farbe für Karosserie und Interieur>>

Choose colors referring to diagram below and painting instructions on P8. Coloring shown in each step is based on a car painted silver and the interior in cream. Paint car telephone (C12) and Recaro seats as you like.

Farbenwahl siehe Seite 8. Die in den einzelnen Steps gezeigte Bemalung der Details ist für einen Wagen mit silberner Karosserie und Interieur in Creme. Telefon C12 und Recaro Sitz wie gewünscht bemalen.

Body Color	Interior Color
Silver	Cream (White: 2 + Desert Yellow: 1)
Metallic Green	Black (Flat Black) and Grey (Light Sea Grey)
White	Brown (Flat Black) and Grey (Light Sea Grey)
Black	Brown (Flat Black) and Grey (Light Sea Grey)
Beige	Brown (Flat Brown) and Cream (Desert Yellow)
Gold	Brown (Flat Brown) and Cream (Desert Yellow)
Maroon	Flat Red and Hull Red
Gun Metal	Flat Red and Hull Red

11 <<Seats>>

<<Sitze>>

- ★ Make 2 sets.
- ★ 2 Satz machen.

White (X-2): 2 + Desert Yellow (XF-59): 1

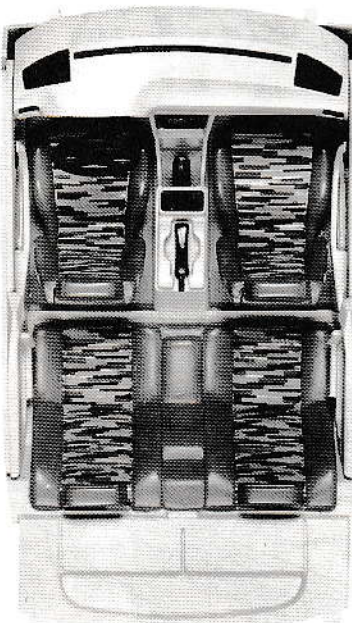

TAMIYA CEMENT PEN

A handy, self-contained pencil sized glue dispenser for accurate application of Tamiya cement right where you want it. Will not dry out in pen. Cement smears are a thing of the past.



9 Assembly of Dashboard Zusammenbau des Armaturenbretts

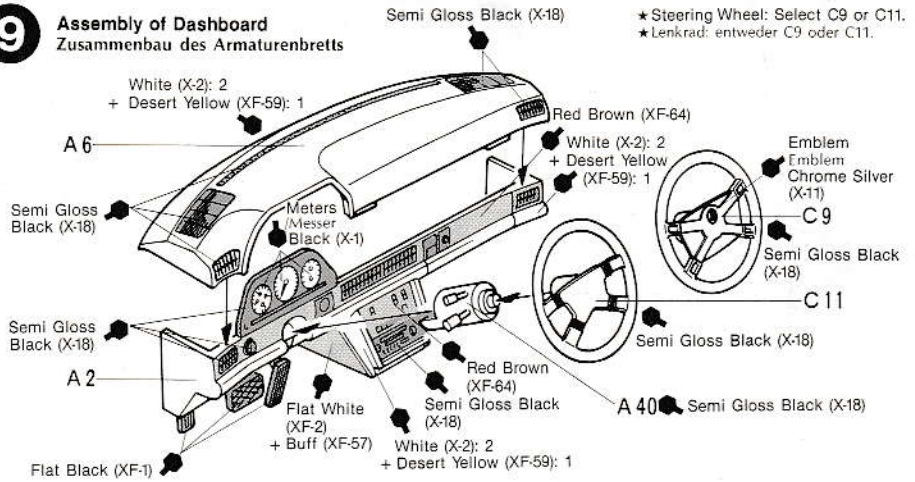

- ★ Steering Wheel: Select C9 or C11.
- ★ Lenkrad: entweder C9 oder C11.

10 Assembly of Interior Parts Innenteile

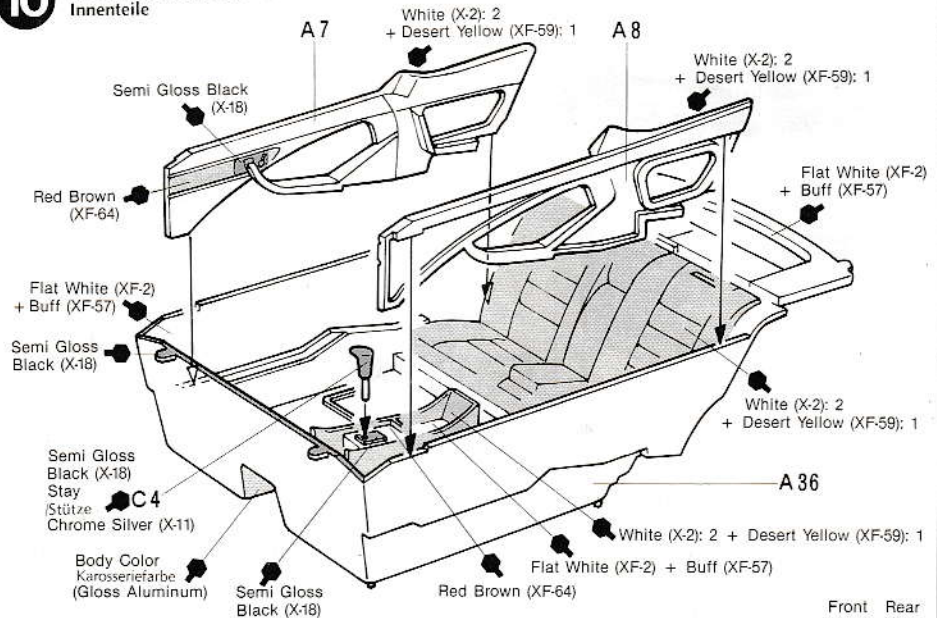

11 Attaching Seats Einbau der Sitze

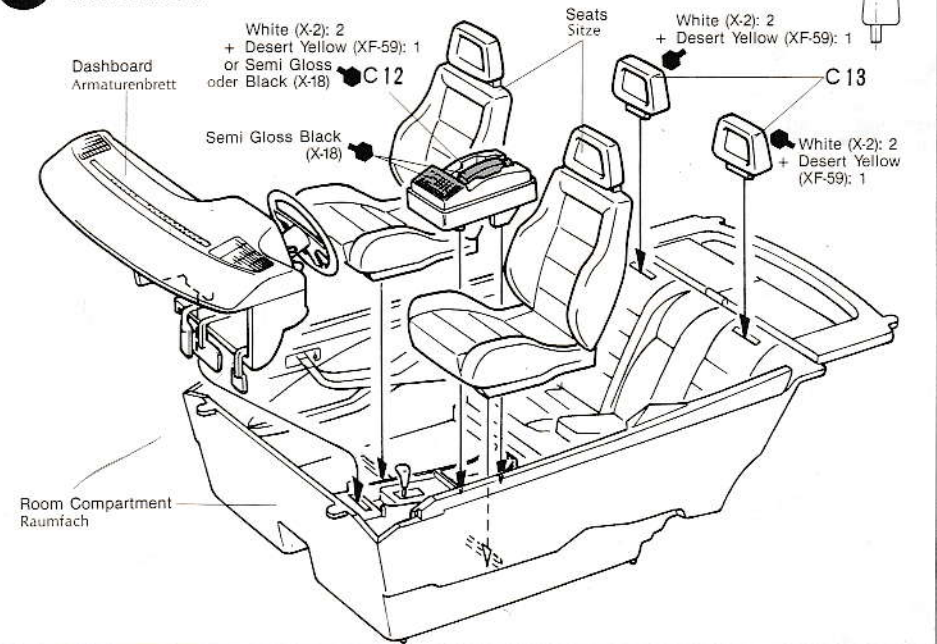

13 <<Painting of Body>>
<<Bemalung der Karosserie>>

Apply overall painting of the body prior to commencing assembly.
Zuerst Karosserie bemalen oder besprühen, dann erst weiterbauen.

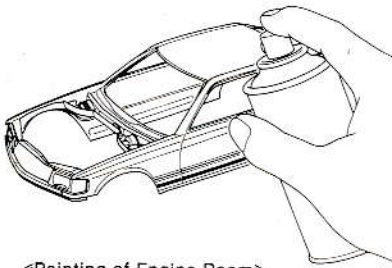

<<Painting of Engine Room>>
<<Bemalung des Motorraums>>

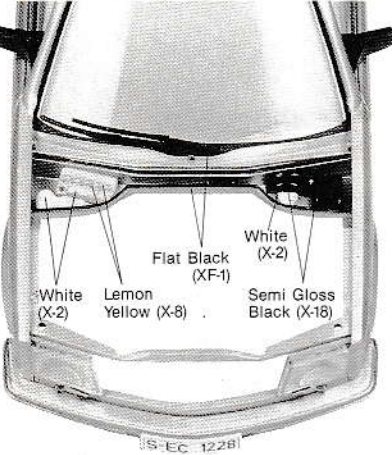

12 Attaching Inside Parts
Einbau des Innenteils

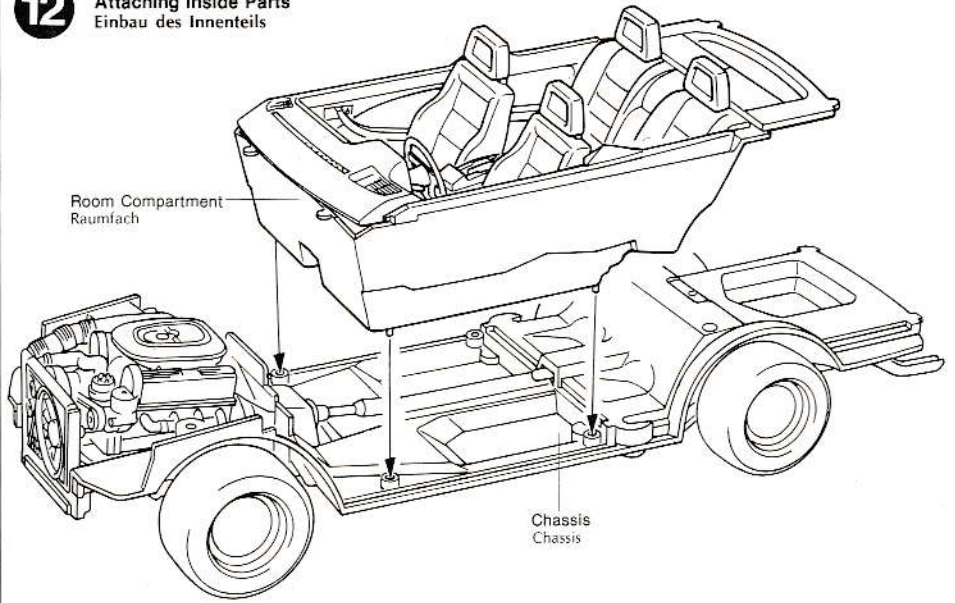

13 Body Interior
Karosserie Innenteile

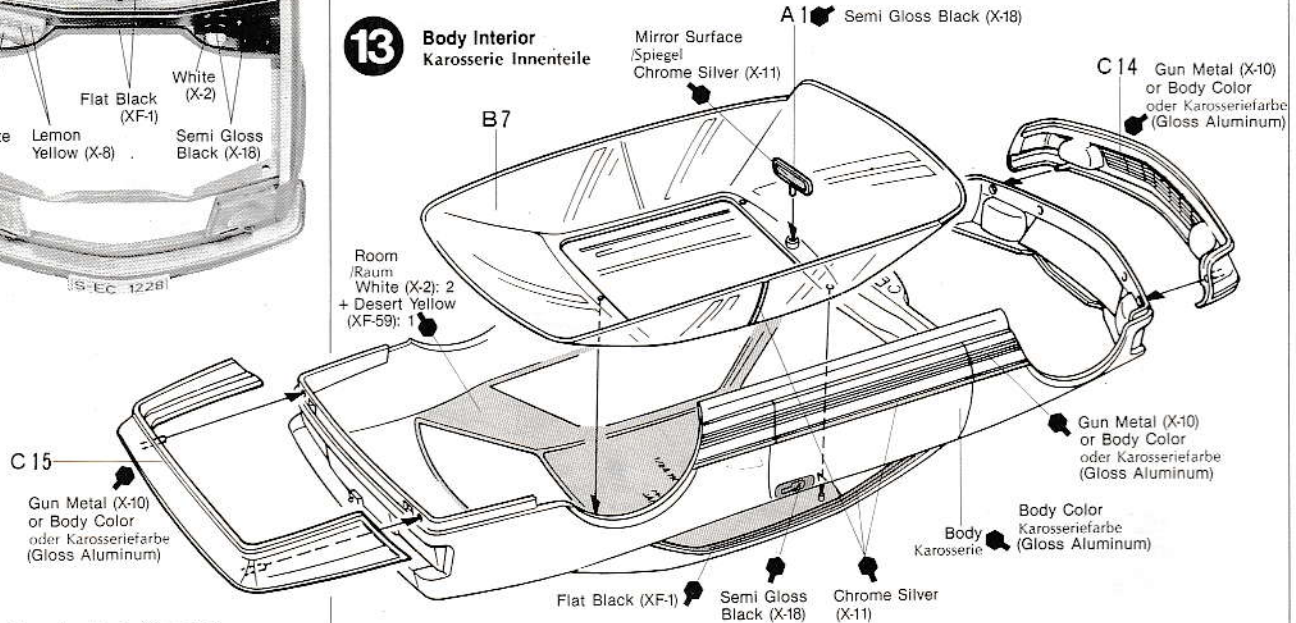

14 <<How to attach Chassis>>
<<Wie Chassis einsetzen?>>

Insert chassis to front body first. Spread body sides apart as shown, then snap chassis pins into slots on body.
Chassis von vorn einsetzen. Es geht leichter, wenn die Karosserie etwas gedehnt wird.

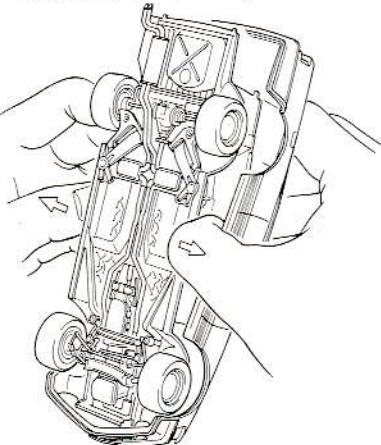

14 Attaching Chassis to Body
Einbau der Karosserie

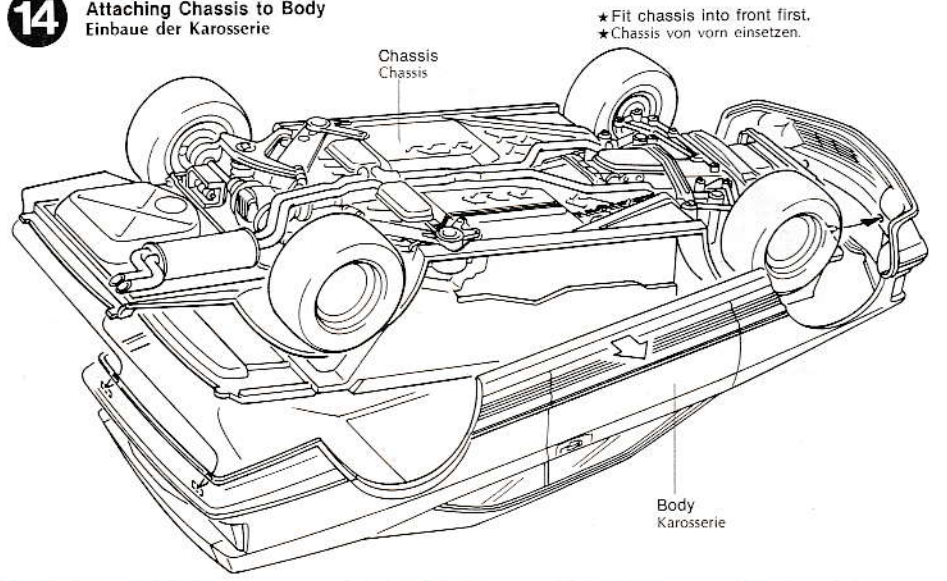

15 <<Painting of Taillights>>
<< Bemalung der Schlussleuchten >>

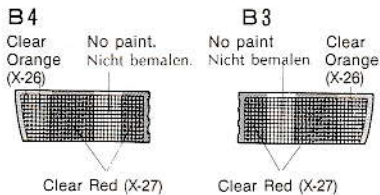

16 <<Completion>>
<< Vollendung >>

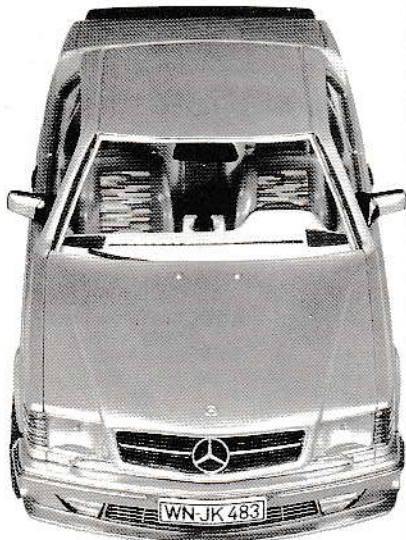

**BUILD A COLLECTION OF TAMIYA
PRECISION CAR**

1/24 MORRIS MINI COOPER



1/24 HONDA BALLADE SPORTS CR-X



1/24 FAIRLADY 280ZT PACE CAR



1/24 CAMPUS FRIENDS SET



TAMIYA
TAMIYA PLASTIC MODEL CO.
628, OSHIKA, SHIZUOKA-CITY, JAPAN.

15 Attaching Taillights
Einbau der Schlussleuchten

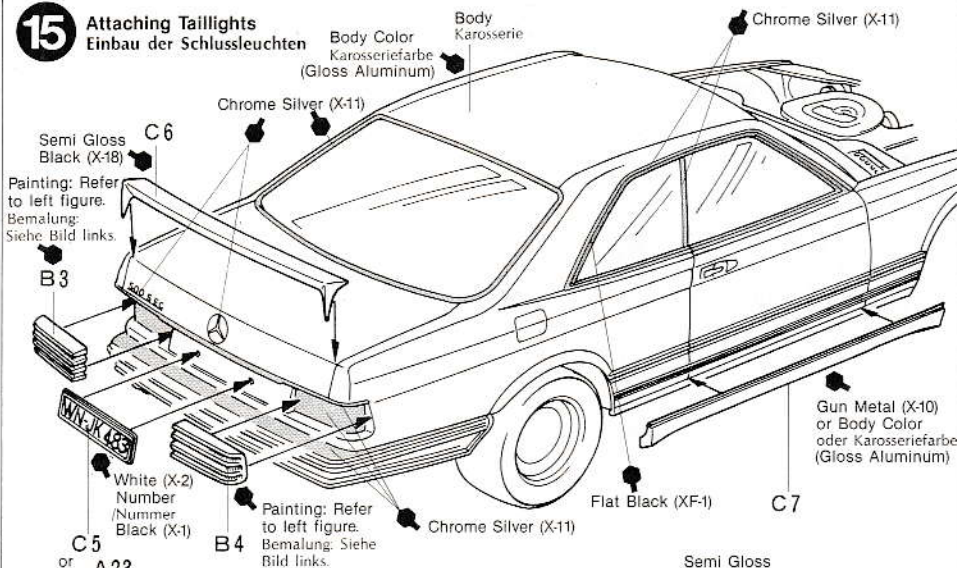

16 Final Assembly
Endmontage

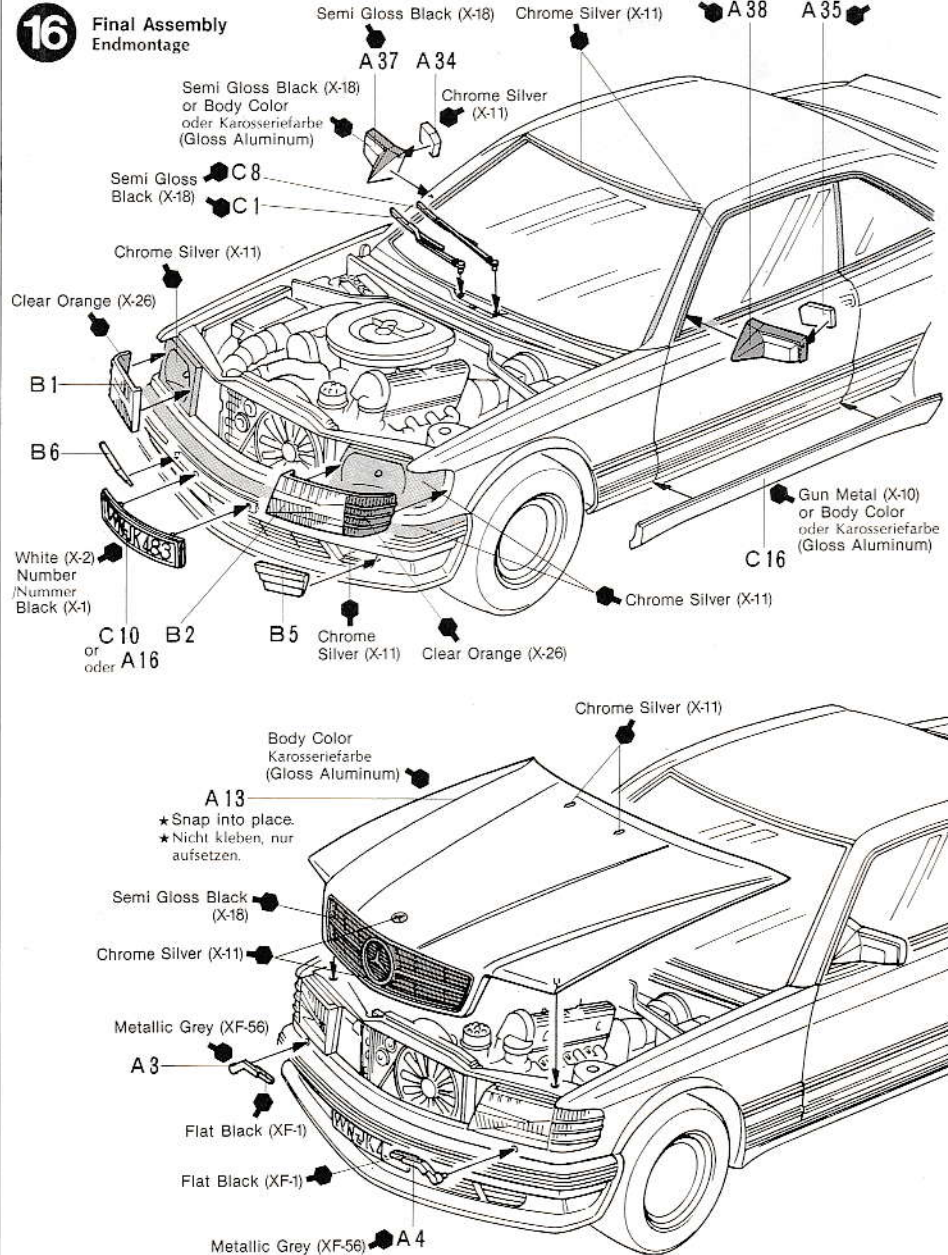

PAINTING

«Painting of the Lorinser 500SEC»

Offered in the standard Benz 26 color combinations for the exterior, and 19 color options for the interior, this top class sports car can be painted to anyone's desires. Typical body and interior styles are shown on page 5. Almost all of the detail painting is called out during construction and should be done at that time.

«Die Bemalung des Lorinser Mercedes 500 SEC»

Neben den 26 Mercedes Standardfarben und den 19 Farb und Stoffmustern für das Innere, kann man diesen Spitzen-Sportwagen natürlich auch in jeder gewünschten Farbzusammenstellung haben. Einige Farben für innen und aussen sind auf Seite 5 gezeigt. Bemalung der Details sind in den einzelnen Baustufen angegeben und sollten auch sofort gemacht werden.

«Colors Required»

★ From Tamiya Acrylic Paints

Black	X-1
White	X-2
Orange	X-6
Lemon Yellow	X-8
Gun Metal	X-10
Semi Gloss Black	X-18
Clear Orange	X-26
Clear Red	X-27
Flat Black	XF-1
Flat White	XF-2
Flat Blue	XF-8
Flat Aluminum	XF-16
Metallic Grey	XF-56
Buff	XF-57
Desert Yellow	XF-59
Red Brown	XF-64

★ From Tamiya Paint Markers

Chrome Silver	X-11
Gloss Aluminum	



TAMIYA ACRYLIC PAINTS
Need precise color matching?
Try the new Tamiya acrylic
paints. Engineered by modelers for
modeler's use. The final cover for the
finest models. Insist on Tamiya for
perfect results.

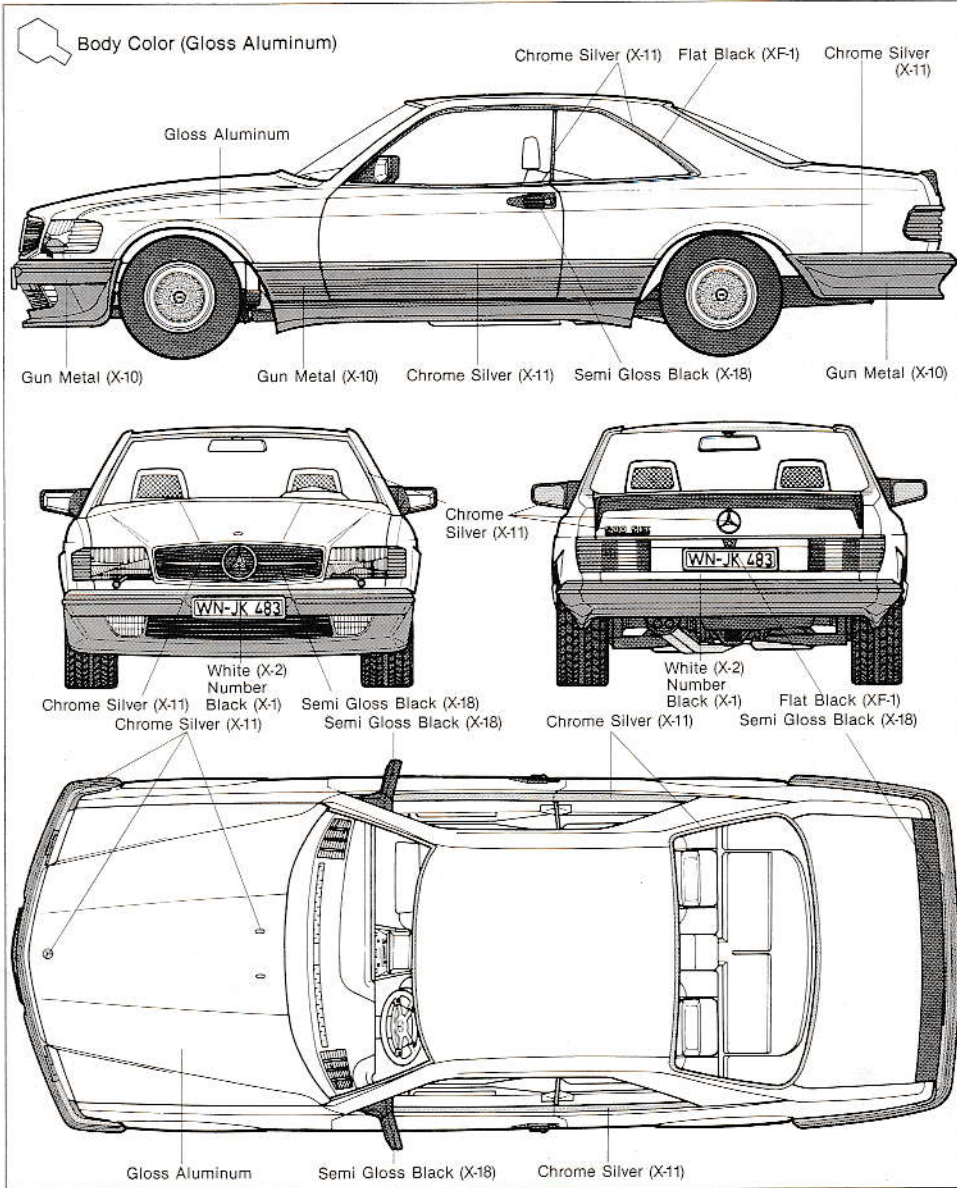

PARTS

A PARTS

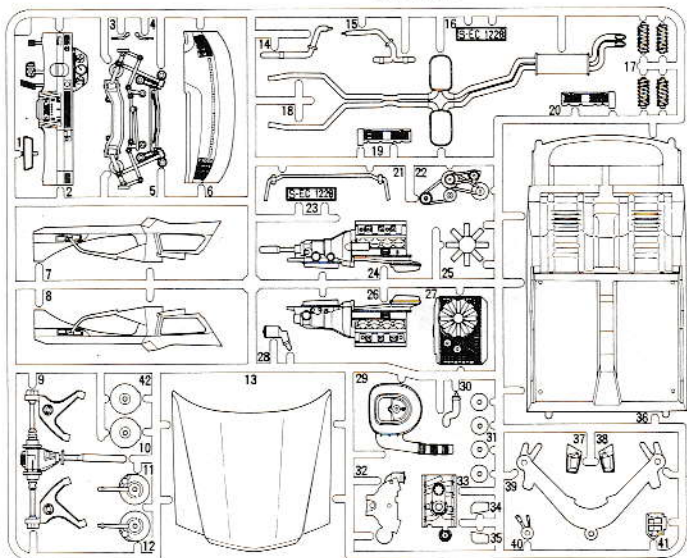

D PARTS



C PARTS

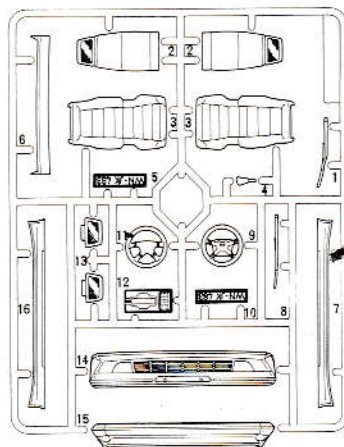

B PARTS

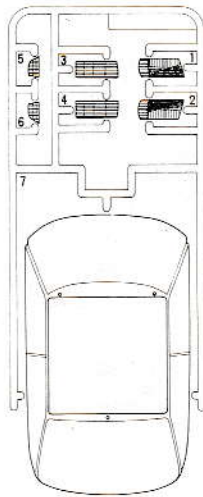

• Body
• Chassis
• Tire Bag
(Tires, Poly Caps)